



BOX 2 650x650

IB3-XY series from 27M to 53M

MANUAL
FOR INSTALLATION,
USE AND MAINTENANCE



GB

INTRODUCTION

Dear Customer,

Thank you for choosing a **CLIVET** product.

The **BOX 2 650x650** model which you have chosen is a high performance product of advanced design and technology, high reliability and quality construction.

We suggest that you entrust its management and maintenance to professionally qualified personnel you trust, who, when necessary, only use original spare parts.

This manual contains important information and tips that must be followed for easier installation and the best possible use of the appliance.

SERIES

MULTISplit Systems		LIGHT Commercial systems	
BOX 2 650x650	IB3-XY series from 27M to 53M	BOX 2 650x650	S.IB3+MC3-Y series from 35M to 53M

SYMBOLS USED IN THE MANUAL AND THEIR MEANING



WARNING

To indicate special information.



CAUTION

To indicate particularly important and delicate operations.



CAUTION DANGER

To indicate actions which, if not carried out correctly, may result in general accidents or may cause malfunctions or material damage to the device; therefore, they require special attention and adequate preparation.



ATTENTION ELECTRIC DANGER

To indicate actions which, if not carried out correctly, may result in accidents of electrical origin; therefore, they require special attention and adequate preparation.



IT IS PROHIBITED TO

indicate actions that **MUST NOT** be performed.



FLAMMABLE MATERIAL

Indicates that the appliance uses a flammable refrigerant.

WARRANTY

The product **CLIVET** is covered by a **conventional warranty**, valid from the date of purchase of the appliance, the conditions of which are specified in the GENERAL CONDITIONS OF SALE available at www.clivet.com



WARNING

- The warranty is void if the appliance has been used without following the instructions in this manual.
- The warranty will be forfeited if the customer makes changes and/or attempts to repair the product himself or through third parties not authorised by the manufacturer/authorised dealer.
- The product must be intended for the use intended by **CLIVET** for which it was expressly made. Any contractual and non-contractual liability **CLIVET** for damage caused to persons, animals or property by installation, adjustment, maintenance and misuse errors is excluded.

INDEX

1 General Details	4	4 Maintenance.....	23
1.1 General warnings and safety rules	4	4.1 Cleaning the indoor unit	23
1.2 Description of system components	6	4.2 Cleaning the air filter	23
1.3 Accessories	7	4.3 Cleaning the outdoor unit	24
1.4 Identification	8	4.4 Repairing refrigerant leaks	24
2 Installation	9	4.5 Extended periods of inactivity	25
2.1 Product receiving	9	4.6 Maintenance at the start of the season	25
2.2 Size and weight	9	4.7 Troubleshooting	26
2.3 Installation - preliminary warnings	9	4.7.1 Common problems	26
2.4 Indoor unit installation	10	4.7.2 Anomalies and remedies	27
2.4.1 Installation room	10	4.8 Error codes displayed on the indoor unit display	28
2.4.2 Hang the indoor unit	12		
2.4.3 Preparation for connection pipes	14	5 Disposal	31
2.4.4 Drainage pipe	14		
2.4.5 Electrical connections	16	6 Attachments	32
2.4.6 Assembling the panel	18	6.1 Indoor unit wiring diagrams	32
3 Use.....	20	6.2 Declaration of conformity	33
3.1 Description of system components	20		
3.2 Manual operation (without remote control)	21		
3.3 Other functions	21		
3.4 Remote control	22		
3.5 Operation	22		

Section dedicated to the USER

1 GENERAL DETAILS

1.1 General warnings and safety rules



WARNING

- This manual is the property of CLIVET and reproduction or transfer to third parties of the contents of this document is prohibited. All rights reserved. It is an integral part of the product; make sure that it is always supplied with the appliance, even in case of sale/transfer to another owner, so that it can be consulted by the user or by personnel authorized to carry out maintenance and repairs.
- Read this manual carefully before using the unit to ensure its safe operation.
- Periodically check the integrity of the power cord, plug and related socket. If the power cable is damaged, it may only be replaced by the manufacturer or the local distributor who sold the appliance or by authorised maintenance and repair personnel.
- The installation must be carried out by an authorized dealer or a qualified technician. Faulty installation may result in water leakage, electric shock or fire.
- Work on the refrigerant circuit must only be carried out by persons with a valid certification, issued by an accredited body, certifying their competence to handle refrigerants safely in compliance with the specifications in force in the sector.
- The installation must be carried out according to the instructions provided. An incorrect installation may cause water leaks, electric shock or fire.
- Install the drain hose according to the instructions in this manual. Incorrect draining can cause water seepage or flooding with possible damage to the home and other property.
- The device must be stored in such a way as to prevent any mechanical damage.
- Consult a qualified technician for unit repair or maintenance.
- Perform the installation using only the supplied accessories and parts specified. The use of non-standard components may cause water leakage, electric shock or fire and cause the unit to malfunction.
- Do not use any means other than those recommended by the manufacturer to accelerate the defrosting process or to clean the unit.
- The appliance must be placed in a room that does not contain any ignition sources operating continuously (e.g. open flames, gas appliances or electric heaters).
- Note that the coolants are odourless.
- Always use the specified cables for all electrical work. Connect the cables securely and secure them in a stable manner to prevent the terminals from being damaged by external forces. Incorrect electrical connection may cause overheating conditions and may result in fire and electrocution.
- The cables must be arranged so that the control board cover can close properly. If the control board cover is not closed properly, corrosion may occur and the connection points on the terminals may become hot, ignite or cause electric shock.
- In some functional environments such as kitchens, server rooms, etc., it is recommended to use specially designed air conditioners.
- The appliance is only suitable for use by children 8 years old and over and persons with reduced physical, sensory or mental capabilities or lack of experience or knowledge when they are properly supervised or have received instructions on the safe use of the appliance and have understood the associated dangers. Prevent children from playing with the appliance. Cleaning and maintenance operations must not be carried out by children without supervision.
- For electrical work, comply with the provisions of the national electrical code, local regulations, current regulations and the requirements contained in the installation manual. It is necessary to use an independent circuit and a single power outlet. Do not connect other appliances to the same electrical outlet. Insufficient electrical capacity or faulty electrical installation may cause risk of electric shock or fire.



CAUTION DANGER

- When connecting refrigerant piping, keep substances or gases other than the specified refrigerant from entering the unit. The presence of other gases or substances can reduce unit performance and cause an abnormal increase in pressure in the refrigeration cycle. This can lead to explosion hazards and resulting injuries.
- Install the unit on a stable stand that can support its weight. If the chosen stand cannot support the weight of the unit, or if the installation is not performed correctly, the unit may fall and cause injury and serious damage.
- Do not pierce or ignite the device.
- The appliance must be placed in a well-ventilated room whose dimensions correspond to those specified for operation.
- The product must be installed with earthing in accordance with the law to avoid the risk of electrocution.
- Do not install the unit in a location that may be exposed to combustible gas leakage. Any accumulation of combustible gas around the unit may cause a fire hazard.
- Do not operate the air conditioner in a very humid room, for example in a bathroom or laundry room. Excessive exposure to water can cause electrical components to short-circuit.



IT IS PROHIBITED TO

- Make changes and/or repair attempts to the product. Any repairs must be carried out by a qualified technician.
- Touch the device with wet, damp and/or barefoot body parts. If you notice current leakage that can be detected on contact with metal parts of the appliance, disconnect the switch, unplug it from the power supply socket and contact an authorised dealer.
- Use of the appliance by children and persons with reduced capacity or lack of experience and specific knowledge unless they are assisted by qualified personnel responsible for their safety.
- Disperse in the environment and leave within the reach of children the packaging material as it may be a potential source of danger. It must therefore be disposed of in accordance with current legislation.
- Change the length of the power cable or use extension cables to power the unit.
- Use the same electrical outlet for other equipment. Incorrect or insufficient power supply may cause fire or electric shock hazard.



NOTES ON FLUORINATED GASES

- This air conditioner contains fluorinated gas. For specific information on gas types and quantities, please refer to the plate found on the unit. It is always necessary to comply with national regulations regarding the use of gases.
- Installation, service, maintenance and repair of the unit must be performed by a qualified technician.
- The uninstallation and recycling of the product must be carried out by qualified technical personnel.
- If a leak detection device is installed in the system, it is necessary to check that there are no leaks at least every 12 months. When checking the unit for leaks, it is recommended to keep a detailed record of all inspections.
- Pay attention to the fact that refrigerant R32 is odourless.



FLAMMABLE MATERIAL

The refrigerant used inside this unit is flammable. A coolant leak that is exposed to an external ignition source can create fire risks

1.2 Description of system components

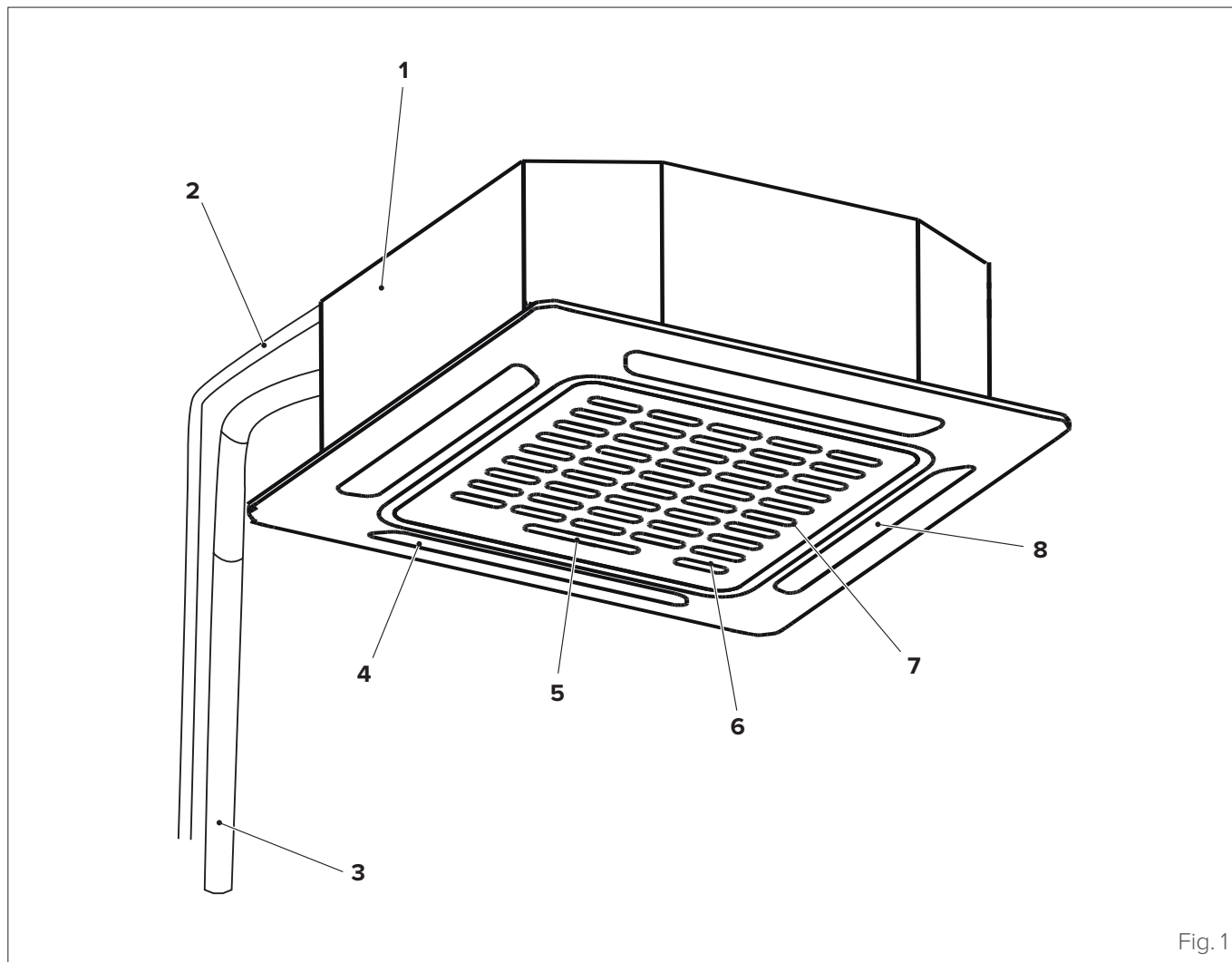

Fig. 1









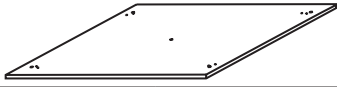

- | | |
|--|-----------------------|
| 1 Drain pump (in the indoor unit) | 5 Display LED |
| 2 Drainage pipe | 6 Front grille |
| 3 Refrigerant piping | 7 Air inlet |
| 4 Ventilation slit | 8 Air outlet |

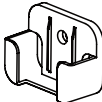
**WARNING**

The images in this manual are provided for illustrative purposes only. The appearance of your device may differ slightly from the illustrations shown here. Refer to the actual characteristics of the unit.

1.3 Accessories

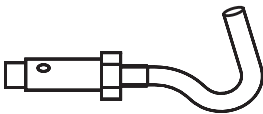
The air conditioner is equipped with the following accessories. Use all specified installation components and accessories to install it. Incorrect installation may cause water leakage, electric shock and fire, or cause the unit to malfunction.

	Description	Aspect	Quantity
Indoor unit installation	Paper template for installation		1
	Installation use and maintenance manual		1
Remote control	Remote control		1
	Remote control support		1
	Fixing screw for the ST2.9 x 10 remote control holder		2
	AAA Alkaline battery. LR03		2
Accessories for refrigerant piping	Connection pipes	Liquid side	Components to be purchased separately. Consult your dealer for pipe sizes.
		Gas side	
	Insulation for gas side pipe fitting		
Insulation for liquid side pipe fitting		1	
Materials for drain pipe	Sheath for the outlet pipe		
	Hose clamp for the outlet pipe		1
	Condensate drain pump		1
Installation accessories	Ceiling hook		4
	Suspension bolt		4
EMC magnetic ring	Magnetic ring (wind electrical cables P, Q and E twice around the magnetic ring)		1
This indoor unit requires the installation of an optional decorative panel			

1.4 Identification

The indoor unit and the outdoor unit can be identified by the serial number label that shows the technical and performance data of the unit and what is required by the legislation in force.

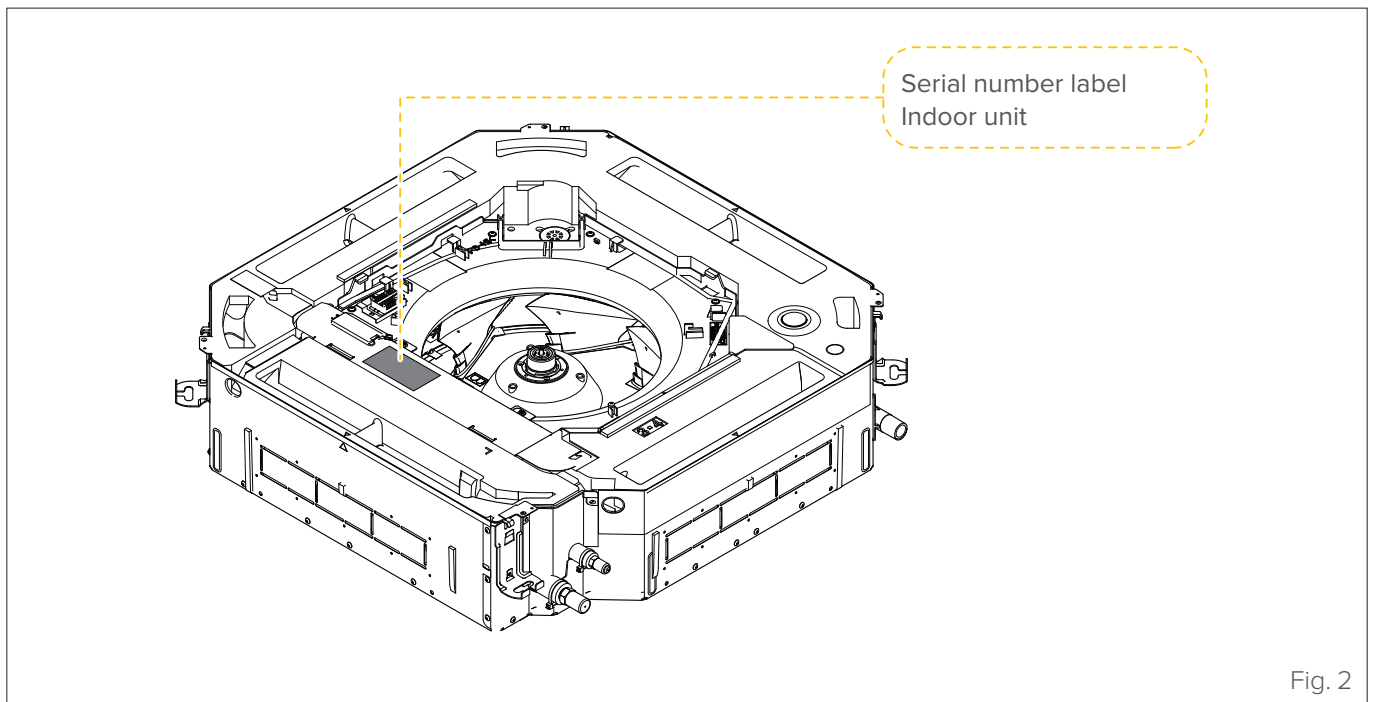

CAUTION

Tampering, removal, lack of identification labels or anything else that does not allow safe product identification, makes any installation and maintenance operation difficult.

2 INSTALLATION

2.1 Product receiving

The appliance is supplied packed in several parcels. Handling must be carried out by appropriate means in view of the overall weight of the package.

Upon receiving the appliance, check the perfect integrity of all parts.

In case of damage to the equipment or missing material, please contact your authorised dealer promptly.



WARNING

The manual is an integral part of the product and therefore it is recommended that you read it before installing and commissioning the device and keep it with care for future reference or transfer to another Owner or User.



IT IS PROHIBITED TO

disperse the packaging material in the environment and leave it within the reach of children as it can be a potential source of danger. It must be disposed of in accordance with current legislation.

2.2 Size and weight

	Indoor unit			
	27M	35M	53M	Panel
Width (mm)	570	570	570	647
Depth (mm)	570	570	570	647
Height (mm)	260	260	260	50
Weight (kg)	14.7	16.2	16.2	2.5

2.3 Installation - preliminary warnings



WARNING

Before installing the indoor unit, consult the label on the product package to check that the model number matches the model number of the outdoor unit.



ATTENTION ELECTRIC DANGER

- All electrical connections must be done by a licensed electrician according to the provisions of national and local electrical codes.
- All electrical connections must be made according to the wiring diagram on the panels of the indoor and outdoor units.
- If the electrical system has serious safety problems, stop work immediately. Explain the situation to the customer and refuse to install the unit until the safety problem has been resolved.
- The power supply should correspond to 90-100% of the rated voltage. Insufficient power supply may cause malfunction, electric shock or fire.
- If the power cables are permanently installed connected to the electrical system, install overcurrent protection and a main power switch with a capacity of 1.5 times the maximum current of the unit.
- The power supply line must have a special protection upstream against short circuits and earthing leakage that sections the system with respect to other utilities. The technician must choose an approved differential circuit-breaker or main circuit breaker.
- Connect the unit to a single socket of a dedicated branch of the circuit. Do not connect other appliances to the same electrical outlet.
- The air conditioner must be properly grounded.
- All cables and conductors must be connected securely. Loosening a conductor may cause the terminal to overheat, which in turn may result in fire hazards or product malfunction.
- The electrical cables must not touch or rest against the refrigerant pipes, the compressor or any moving parts of the unit.

2.4 Indoor unit installation

2.4.1 Installation room



CAUTION

The appliance must be placed in a well-ventilated room, with a minimum surface area that varies according to the amount of refrigerant present.

To calculate the minimum area of the installation room, proceed as described below:

- determine the total refrigerant charge (see section “3.1.1 Refrigerant charge” of the outdoor unit manual)
- identify the refrigerant charge value in the table below and derive the respective minimum area required for the installation room.

Refrigerant charge [kg]	Minimum surface [m ²]
< 1.842	-
1.843	3.64
2.0	3.95
2.2	4.34
2.4	4.74
2.6	5.13
2.8	5.53
3.0	5.92
3.2	6.48
3.4	7.32
3.6	8.20
3.8	9.14
4.0	10.1
4.2	11.2
4.4	12.3
4.6	13.4
4.8	14.6
5.0	15.8
5.2	17.1
5.4	18.5
5.6	19.9
5.8	21.3
6.0	22.8
6.2	24.3
6.4	25.9
6.6	27.6
6.8	29.3
7.0	31.0

Refrigerant charge [kg]	Minimum surface [m ²]
7.2	32.8
7.4	34.7
7.6	36.6
7.8	38.5
7.956	40.1

The following information can help you choose a suitable location for the indoor unit.

The installation location must have the following characteristics:

- good air circulation.
- ease of drainage.
- the noise emitted by the unit must not disturb other people.
- stability and robustness - no exposure to vibration.
- sufficient capacity to support the weight of the unit. **If the structure** is too weak, the unit can fall and cause serious or fatal personal injury, material damage and damage to the appliance.
- at least one metre away from any other electrical device (e.g. TV, radio, computer).
- installation at least 2.5m off the floor.
- if the indoor unit is installed on a metal part of the building, it must be earthed.
- the unit must be at least 1m away from the nearest wall.
- the space must be sufficient for installation and maintenance operations.
- the space must be sufficient for connection of the piping and drain pipe.
- the ceiling must be horizontal and its structure must be strong enough to support the weight of the indoor unit.
- the air inlet and outlet must not be blocked.
- the air flow must be able to reach the whole room.



It is PROHIBITED to install the indoor unit in the following locations:

- in a bathroom or laundry room, because excess humidity can reduce its service life and corrode the cables;
- near sources of heat, steam or combustible gas;
- near flammable objects, such as curtains or fabrics;
- near obstacles that could obstruct air circulation;
- near the entrance;
- In an area that is not exposed to direct sunlight;
- areas exposed to strong electromagnetic waves;



It is PROHIBITED to install the indoor unit in the following locations:

- oil extraction drilling or fracking areas;
- coastal areas with extremely salty air;
- areas with an atmosphere impregnated with caustic gases, for example near thermal sources;
- areas subject to strong power fluctuations, for example factories;
- enclosed spaces (cabinets, etc.);
- kitchens with natural gas cooker hobs;
- areas used for storing gas or flammable materials.

Please refer to the following diagram for wall and ceiling distances:

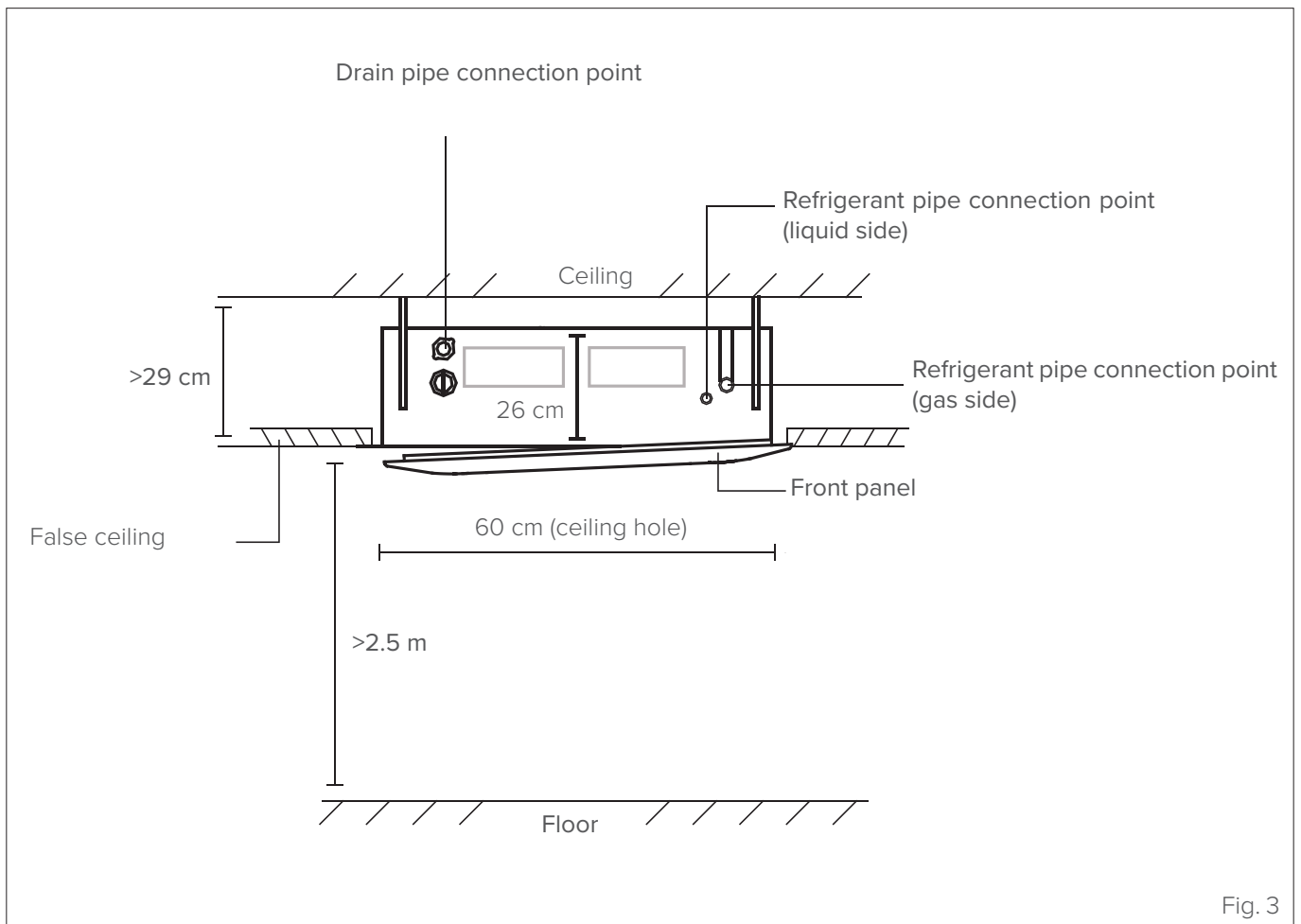

Fig. 3

2.4.2 Hang the indoor unit

- Using the paper template provided, make a rectangular hole in the ceiling leaving a clearance of at least 1 m on all sides. The hole must measure 60x60 cm. Mark the areas where the holes for the ceiling hooks are to be drilled.

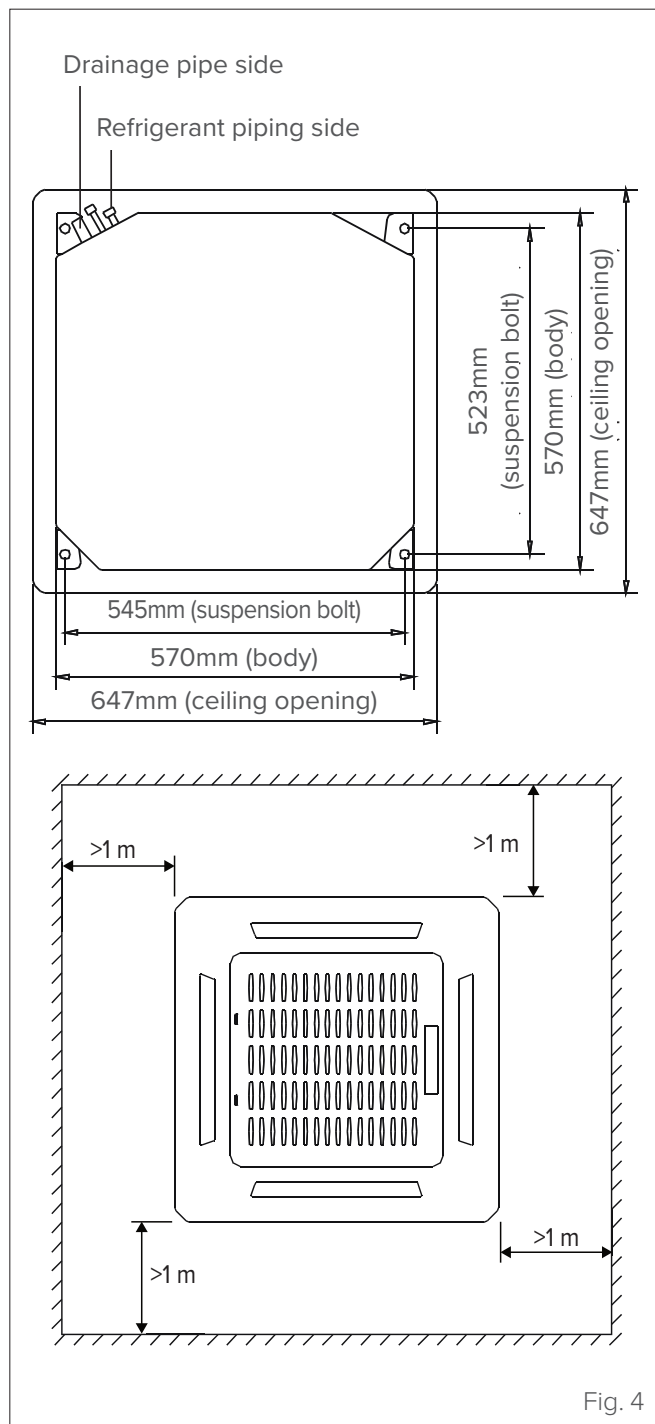

Fig. 4



CAUTION DANGER

The unit body must be aligned exactly with the hole. Before proceeding, check that the hole is the same size as the unit.

- Drill four 5cm holes in the internal ceiling, in the positions marked for the hooks. Keep the drill bit at a 90° angle to the ceiling.

- Hammer the ceiling hooks into the holes. Fasten the bolt with the washers and nuts provided.
- Install the four suspension bolts.

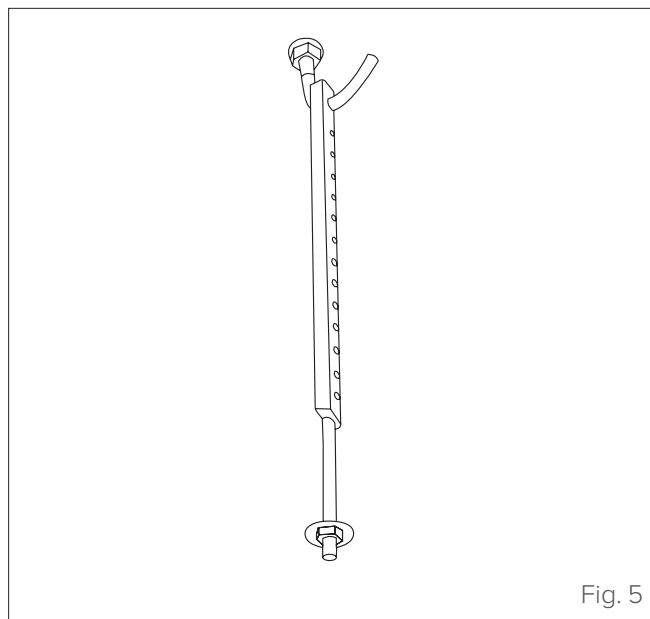

Fig. 5

- Assemble the indoor unit. Two people are needed to lift and fasten the unit. Insert the suspension bolts into the holes for attaching the unit. Fasten them with the washers and nuts provided.

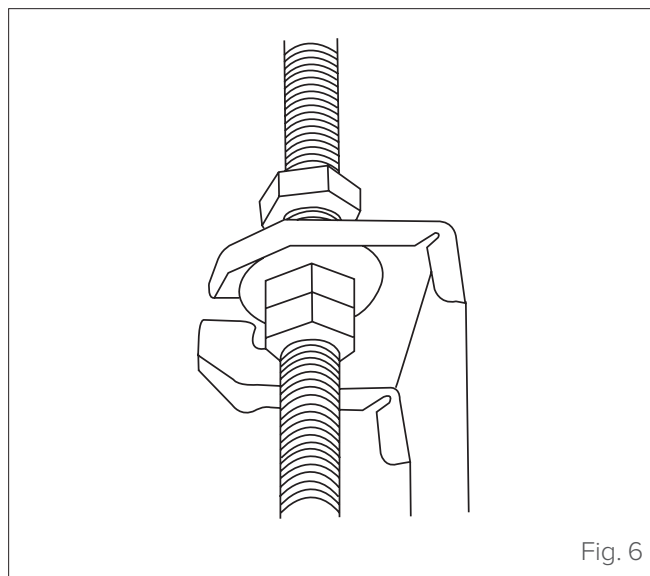

Fig. 6



WARNING

The bottom of the unit must be 24 mm higher than the false ceiling. In general, measurement "L" must half the length of the suspension bolt or be long enough to stop the nuts from coming off.

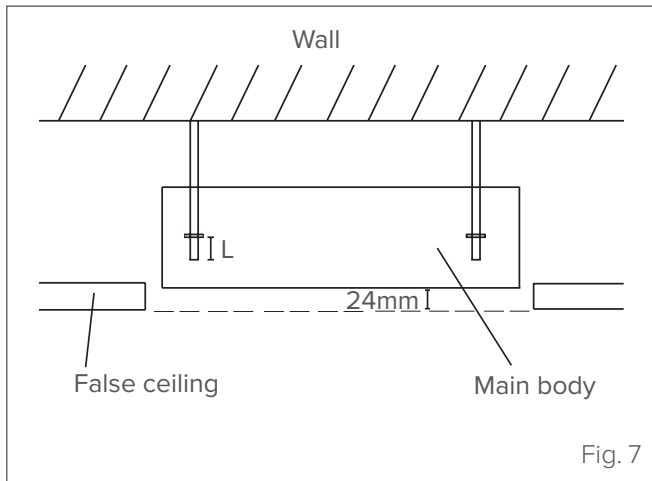

Fig. 7



CAUTION DANGER

Check that the unit is completely horizontal. Incorrect installation can cause the drain pipe to go back into the unit or possible water leaks.

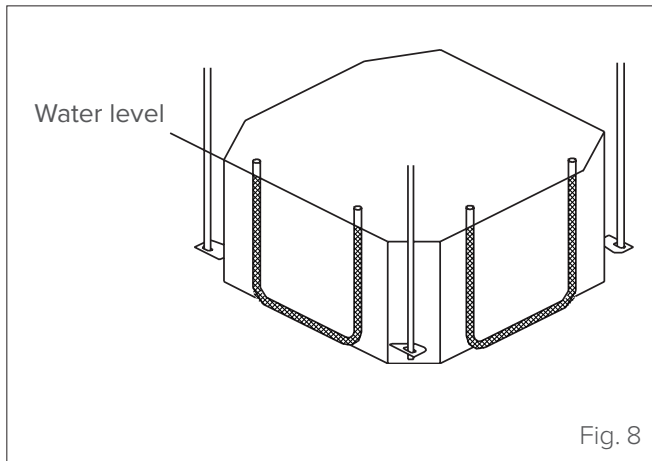

Fig. 8



WARNING

Check that the indoor unit is horizontal. The unit has a drain pump and a float switch. If the unit tilts in the opposite direction to that of the condensate flow (with the drain pipe side raised), the float switch may not work properly and cause a water leak.

NOTE FOR INSTALLATION IN NEW BUILDS

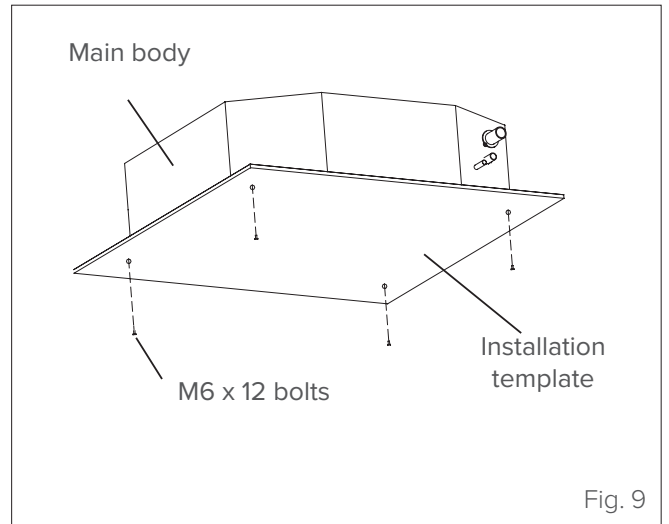

Fig. 9



WARNING

When the unit is to be installed in a new build, the hooks may already be fitted in the ceiling. In this case, check that the hooks have not come loose due to concrete shrinkage. After installing the indoor unit, fit the installation template on the unit (with M6X12 bolts) to determine the size and the position of the opening to be made in the ceiling. Continue with the installation following the instructions above.

2.4.3 Preparation for connection pipes

It is necessary to make a hole in the wall where the refrigerant piping, drainage pipe and electrical cables that will connect the indoor unit to the outdoor unit will pass through.

- 1 Determine hole position in the wall according to the position of the outdoor unit. The hole in the wall should have a minimum diameter of 65 mm and a slight downward slope to facilitate drainage (see "Fig. 10").
- 2 Drill the hole in the wall using a 65 mm drill bit. The hole should have a slight inclination, so that the outer end is lower than the inner one by about 12 mm. This will facilitate water drainage.

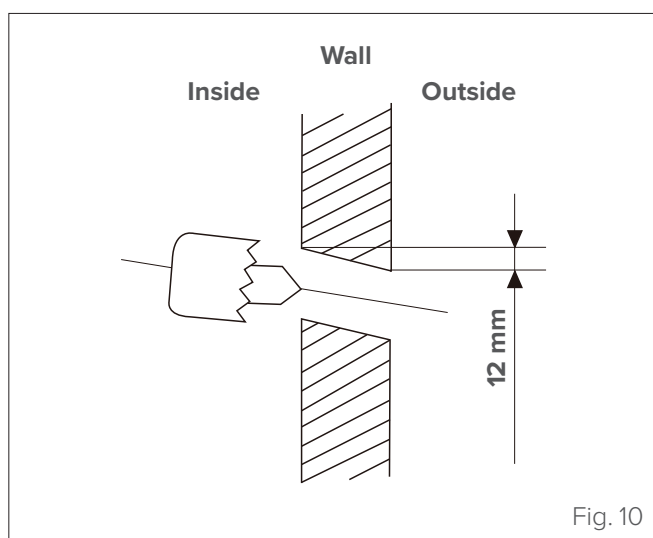

- 3 Insert the protective sleeve into the wall, which will protect the edges of the hole and improve the seal after installation.



CAUTION DANGER

When drilling holes, pay attention to avoid electrical wires, hydraulic hoses and other delicate components.



CAUTION

The drain pipe outlet must be at least 5 cm from the floor. If it touches the ground, the unit can block and not work properly. If the water is discharged directly into the sewer system, use a U- or S-shaped drain pipe to block odours which would otherwise flow back inside.

2.4.4 Drainage pipe

The drainage pipe is used to drain the water from the unit. Incorrect installation can cause damage to the unit and other material damage.



CAUTION DANGER

- Insulate all of the pipes to prevent condensate from forming, which could cause water damage.
- If the drainage pipe is bent or not installed properly, the water can escape and cause the float switch to malfunction.
- In HEAT mode, the outdoor unit discharges water. Make sure that the drainage pipe is in a suitable area to avoid water damage and slipping hazards caused by the discharge water freezing.
- **DO NOT** pull the drainage pipe, as this could detach it.



WARNING

A polyethylene pipe (outer diameter = 3.7-3.9cm, inner diameter = 3.2cm) is required for this installation, which you can find in hardware shops or from your local dealer.

Installation

- 1 Install the drainage pipe as shown in the figure:

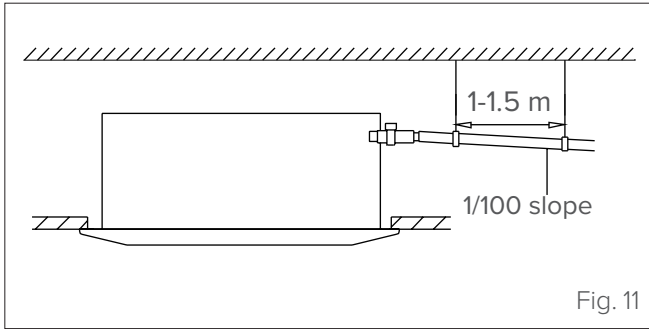

Fig. 11

- 2 Cover the drainage pipe with a heat-insulating material to prevent condensate and possible water leaks.
- 3 Connect the end of the drainage pipe to the unit's outlet pipe. Wrap the end of the pipe and securely fasten it with a hose clamp.

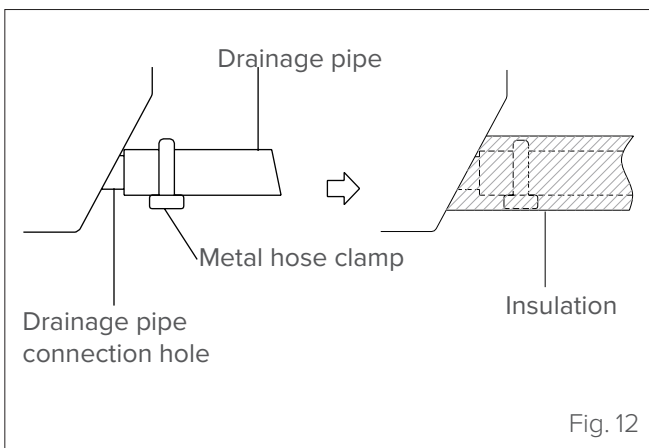

Fig. 12

- 4 If connecting more than one drainage pipe, follow the installation diagram below:

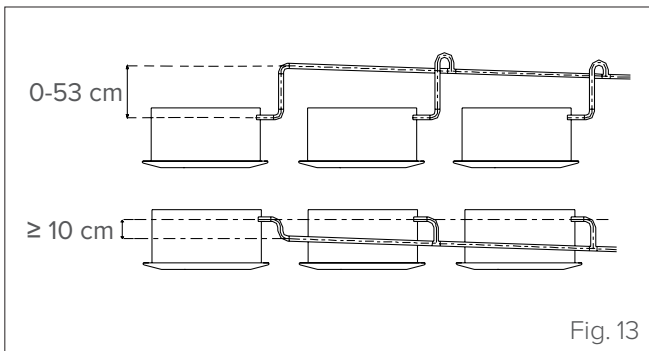

Fig. 13



WARNING

- When using an extension for the drainage pipe, tighten the connection on the inside with an additional protection pipe to stop it from coming loose.
- The drainage pipe must slope by at least 1/100 to prevent the water from flowing back into the air conditioner.
- To stop the pipe from bending, fix the suspension elements every 1-1.5 m.
- If the drainage pipe outlet is higher than the pump fitting on the unit body, use a lifting pipe for the discharge outlet of the indoor unit. The lifting pipe must be installed no more than 75 cm from the false ceiling and no further than 30 cm from the unit. Incorrect installation can cause the water to flow back into the unit.
- To prevent air bubbles from forming, keep the drainage pipe horizontal or slightly inclined upwards (<75 mm).

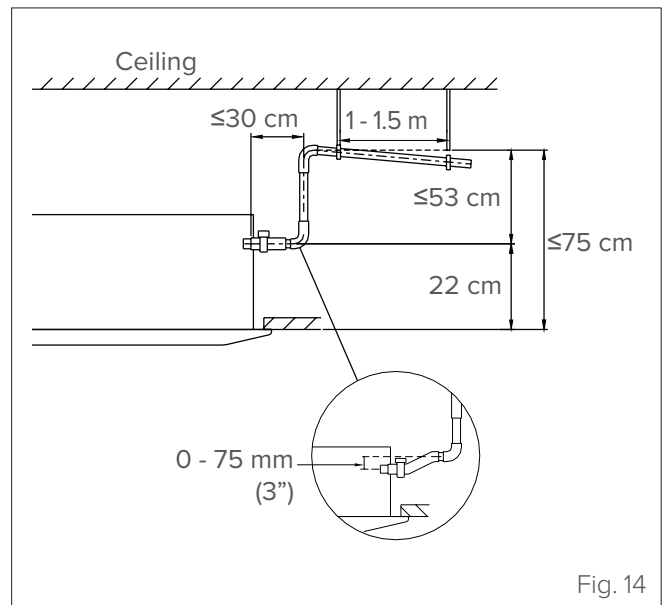

Fig. 14

DRAIN TEST

Check that the drainage pipe is not blocked. This test must be carried out in new builds before finishing the ceiling.

2.4.5 Electrical connections

Cables with the following characteristics are required for power supply and communication between the indoor and outdoor units:

Indoor unit	Power supplied from outdoor unit	Signal from outdoor unit
	no.of cables/cross section	no.of cables/cross section
27M	2 x 1mm ² + G	2 x 1mm ²
35M	2 x 1mm ² + G	2 x 1mm ²
53M	2 x 1mm ² + G	1 x 1mm ²

The indicated cross-sections are suitable for a wiring length of up to 5 metres.



ATTENTION ELECTRIC DANGER

Before making electrical connections, turn off the main switch of the system.



WARNING

WRITE DOWN THE SPECIFICATIONS OF THE FUSES.

The air conditioner board (PCB) is equipped with a fuse for overcurrent protection. Fuse specifications are printed on the circuit board, for example:

Indoor unit: T5A/250VAC

NOTE: The fuse is ceramic.

1 Prepare the cable for connection:

- Using a wire stripper, strip the rubber sheath at both ends of the cable and expose approximately 15 cm of the internal conductors.
- Strip the insulation sheath at the ends of the conductors.
- Using a crimping tool, crimp U-type wire terminals to the ends of the conductors.



CAUTION

When crimping, clearly identify live cables ("L") and other cables.

2 Open the front panel of the indoor unit.

3 Take the cover off the electrical panel on the indoor unit with a screwdriver. This will give you access to the terminal block.



WARNING

All connections must be made exactly as shown in the wiring diagram on the inside of the terminal block cover of the indoor unit.

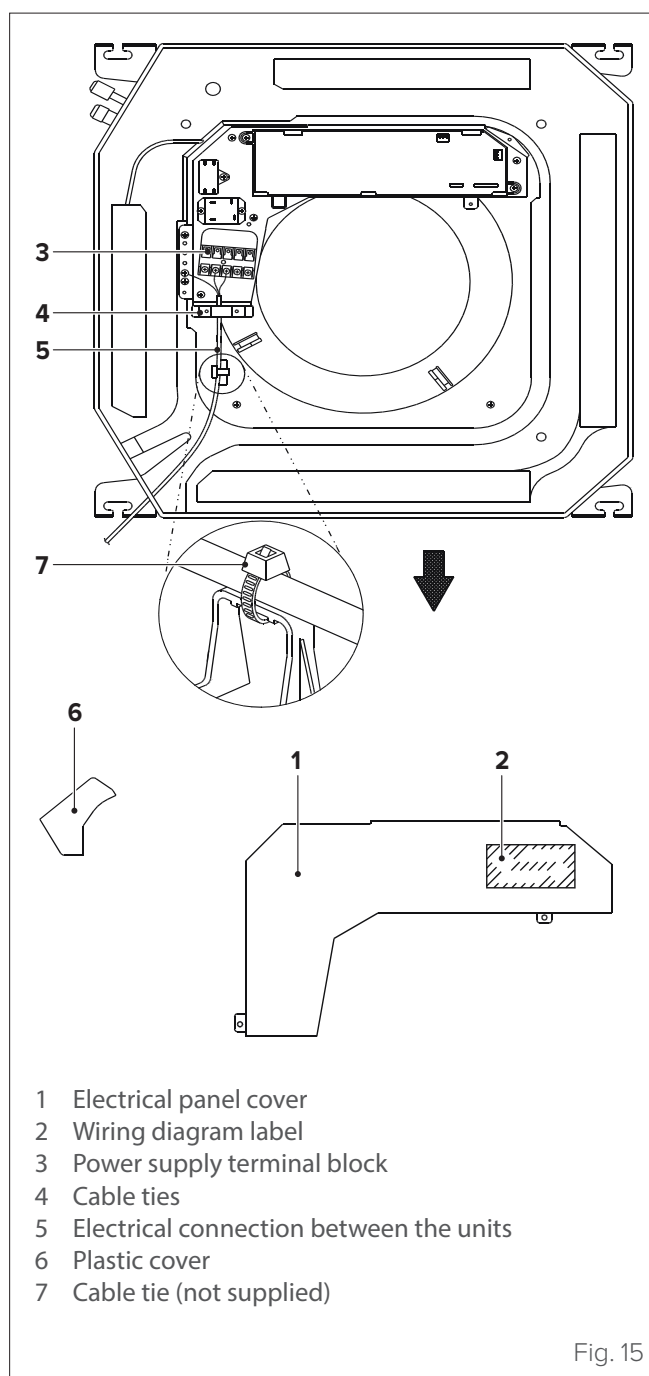

Fig. 15

4 Pass the power cable and the signal cable through the cable outlet.

5 Connect the U-shaped wire terminal to the terminals. Match the colours/labels of the cables to the labels on the terminal block, then screw the U-shaped wire terminal of each cable firmly to the corresponding terminal block. Refer to the serial number and wiring diagram on the cover of the electrical panel.

6 Route the electrical cables through this opening, proceeding from the back of the unit to the front.

7 Looking at the front side of the unit, match the colours of the cables to the labels on the terminal block, connect the U-shaped terminals and screw each cable securely to the corresponding terminal.



CAUTION DANGER

- DO NOT SWITCH LIVE AND NEUTRAL CABLES. Such a configuration is dangerous and may cause the air conditioner to malfunction.
- The refrigerant circuit can get very hot. Keep the interconnection cable away from the copper pipe.

- 8 Secure the cables with the corresponding cable ties. The cable must not be slack and must not pull the U-shaped wire terminal.
- 9 Refit the electrical panel cover and the front panel on the indoor unit.

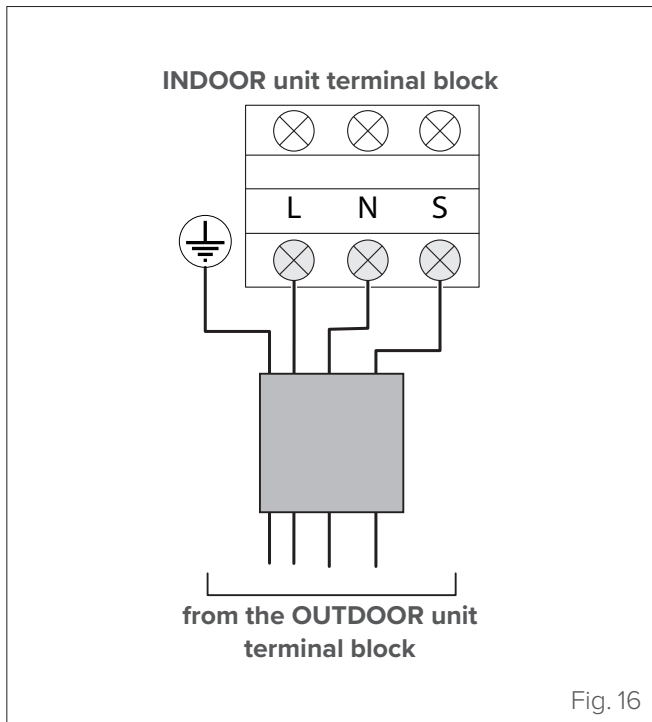

Fig. 16

REMOTE ON-OFF

For the input of the remote control terminal CN23 (ON-OFF) and the JR6 quick-release connector

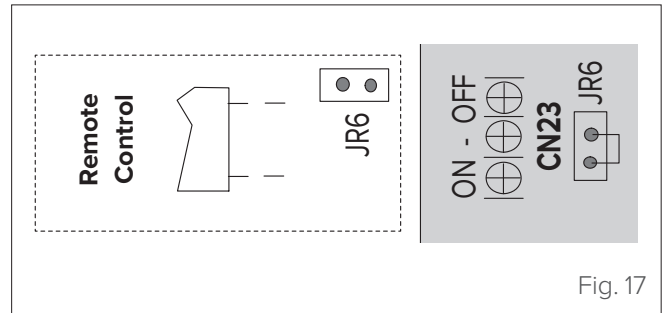

Fig. 17

- Remove the JR6 quick-release connector when using the ON-OFF function;
- When the remote switch is OFF (OPEN), the unit will be turned off;
- When the remote switch is ON (CLOSE), the unit will be turned on;
- When the remote switch is opened/closed, the unit will respond to the request within 2 seconds;
- When the remote switch is ON, the remote/wired control can be used to select the mode; when the remote switch is OFF, the unit will not respond to the remote/wired control request.

When the remote switch is OFF, the remote/wired control is on, code CP will be shown on the display board.

- The input voltage is 12 V DC, the maximum design current is 5 mA.

ALARM

For the input of ALARM connector CN33

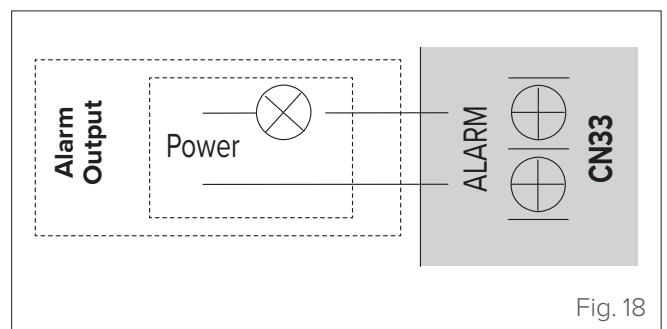
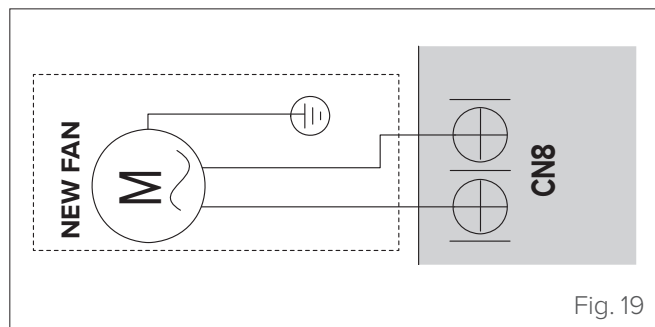

Fig. 18

- The terminal input is set up for ALARM connection, but there is no voltage; the power supply comes from the ALARM system (not from the unit)
- Although the design voltage can withstand even higher values, we strongly advise connecting a power supply of less than 24 V and a current of less than 0.5 A
- If this problem occurs on the unit, the relay will be closed, thus activating the ALARM

OUTDOOR AIR FAN

For the input of terminal CN8 of the new outdoor air motor



- Connect the fan motor to the input, regardless of the motor's L/N;
- The output voltage is the power supply;
- The outdoor air motor cannot exceed 200 W or 1A; choose the lower value;
- The new outdoor air motor will start when the internal fan motor is running; when this motor stops, the outdoor air motor also stops;
- When the unit goes into forced cooling mode or power test mode, the outdoor air motor will not work.

2.4.6 Assembling the panel



IT IS PROHIBITED TO

place the panel face down on the floor, against a wall or on an uneven surface.

1 Remove the front grille.

- Push the two tongues towards the centre at the same time to unlock the grille catch

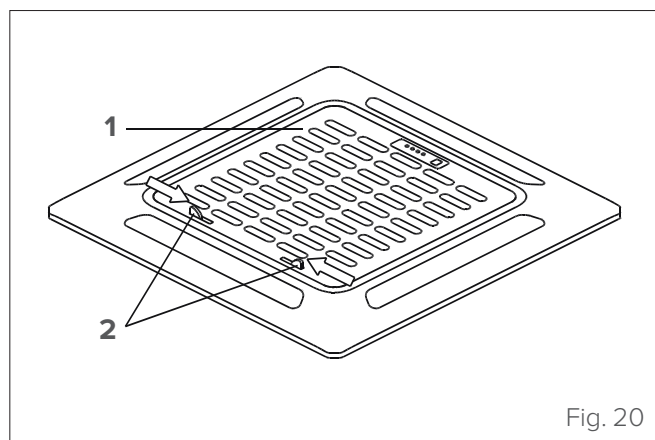

- Holding the grille tilted at 45°, lift it slightly and detach it from the main body.

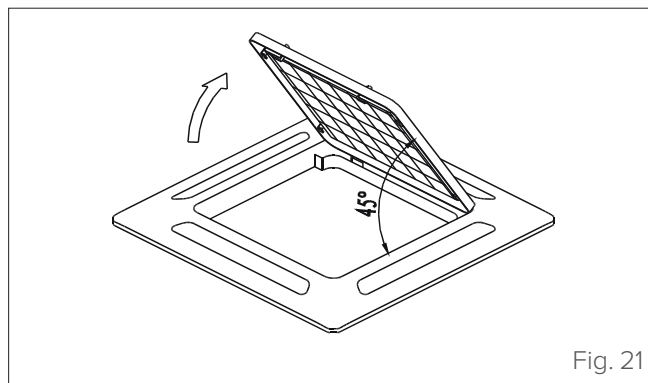

2 Install the panel

- Align “△” on the decorative panel with “△” on the unit. Fit the decorative panel on the unit using the screws supplied, as shown in the figure below.

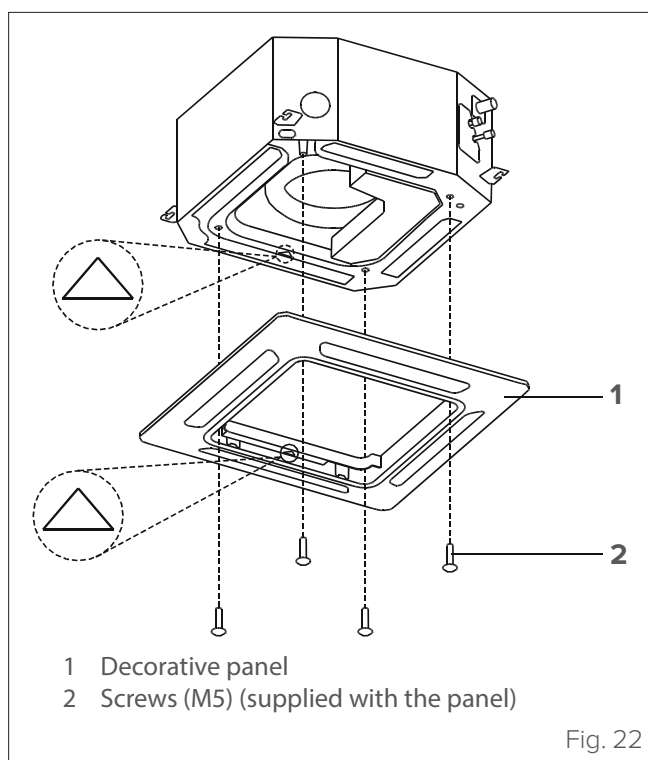

- After installing the decorative panel, make sure that it is perfectly flat against the unit body. If it is not, air could pass through the gap and cause condensate to form.

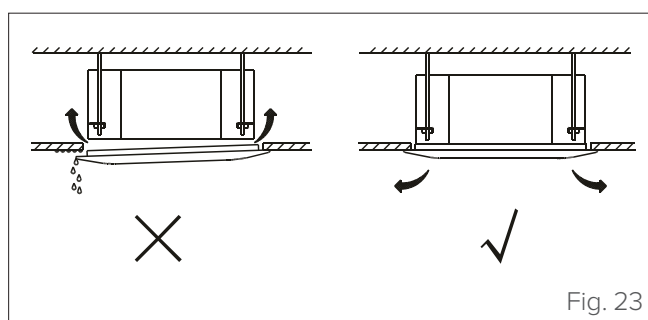

Installation

- 3** Assemble the intake grille.
- Check that the hooks on the back of the grille fit correctly into the panel slot.

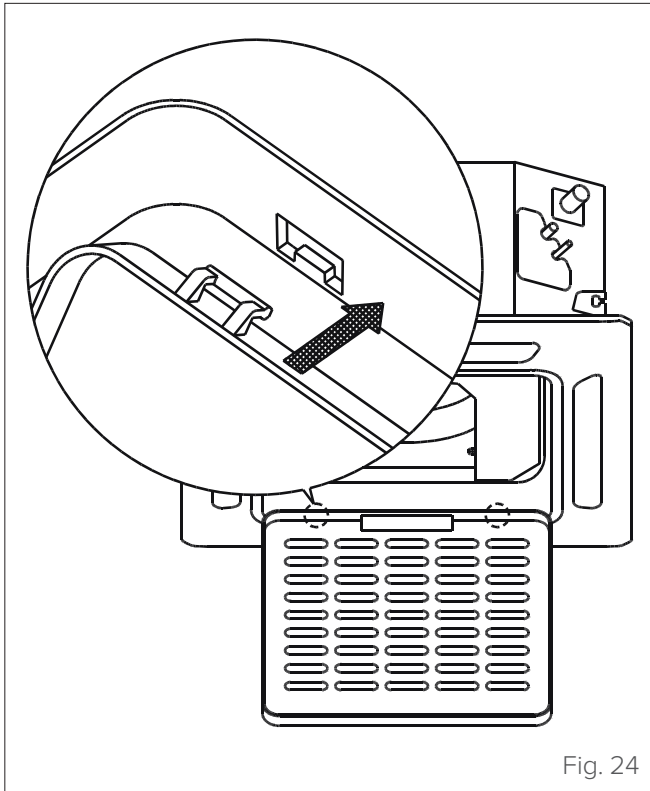

- 4** Connect the two decorative panel cables to the main unit board.

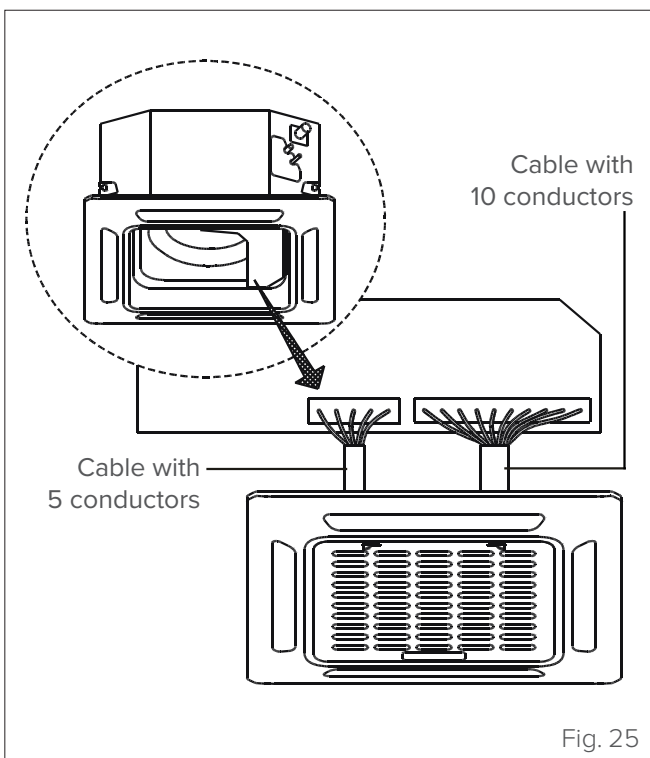

- 5** Fasten the electrical panel cover with two screws.

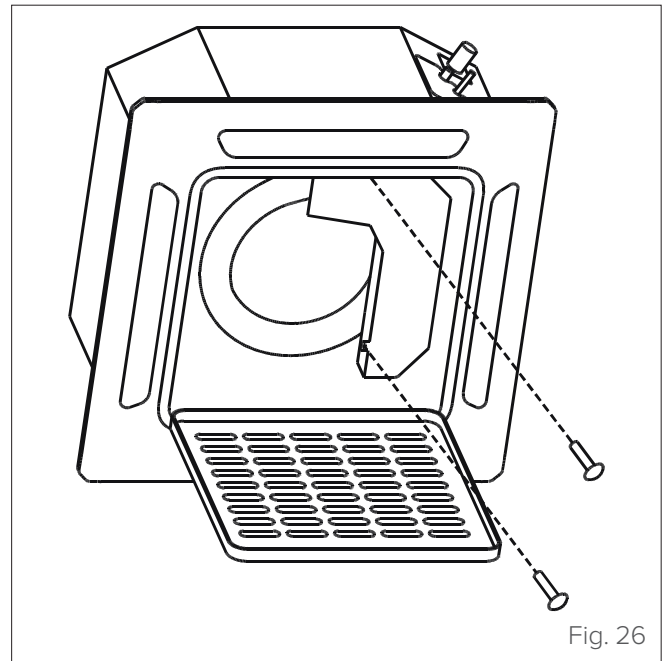

- 6** Close the intake grille and close the two hooks.

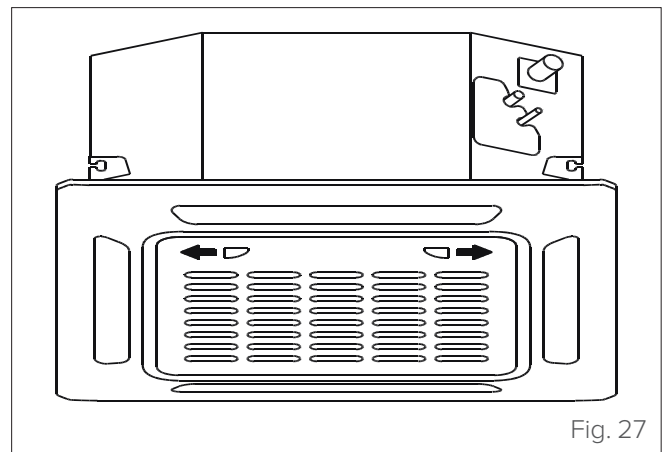

3 USE

3.1 Description of system components

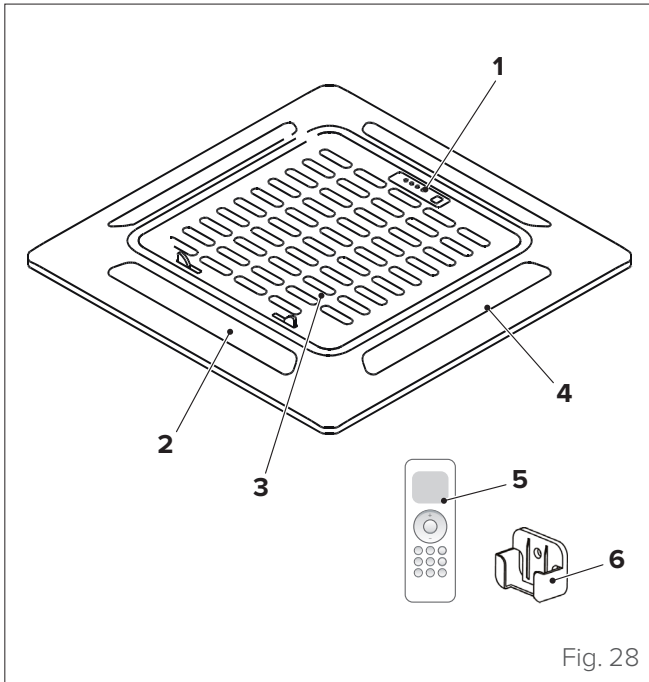

Fig. 28

- 1 Display LED
- 2 Ventilation slit
- 3 Air inlet
- 4 Air outlet
- 5 Remote control
- 6 Remote control support



WARNING

The images in this manual are provided for illustrative purposes only. The appearance of your device may differ slightly from the illustrations shown here. Refer to the actual characteristics of the unit.



CAUTION DANGER

- If an abnormal condition occurs (e.g. there is a smell of burning), turn the unit off immediately and ask the dealer for assistance to avoid the risk of injury, fire or electrocution.
- DO NOT allow the indoor unit or the remote control to get wet. Humidity can cause an electric shock or a fire risk.
- DO NOT insert fingers, bars or other objects into the air inlet or outlet openings. These operations can be dangerous because the fan can rotate at high speed.
- DO NOT use flammable sprays, such as hairspray or paint, near the unit. These materials can cause fire or combustion.



WARNING

- DO NOT touch the air outlet while the flaps are swinging. Fingers can get trapped or the unit can break down.
- To prevent the appliance from deteriorating, do not use the air conditioner for preservation purposes (food, plants, animals, works of art, etc.).
- DO NOT touch the indoor unit's evaporator coils. The evaporator coils are sharp and can cause personal injury.
- DO NOT place objects that are not resistant to humidity under the indoor unit. A relative humidity of 80% can cause condensate to form.
- DO NOT expose heat generating appliances to cold air and do not place them under the indoor unit. The air flow can cause incomplete combustion, while the heat can cause the unit to deform.
- After long periods of use, check the indoor unit to make sure that it is not damaged. Damage can cause the indoor unit to fall and cause personal injury.
- If the air conditioner is used at the same time as other heating devices, the room must be aired properly to avoid oxygen deficiencies.
- DO NOT use the air conditioner if an insecticidal fumigant is used in the room. The chemicals can be absorbed by the unit and create dangerous situations for people who are hypersensitive to those substances.

3.2 Manual operation (without remote control)

If the remote control does not work, the unit can be operated manually with the **manual control** button located on the indoor unit. Note that manual operation is only a temporary solution, and it is highly recommended to run the unit with the remote control.

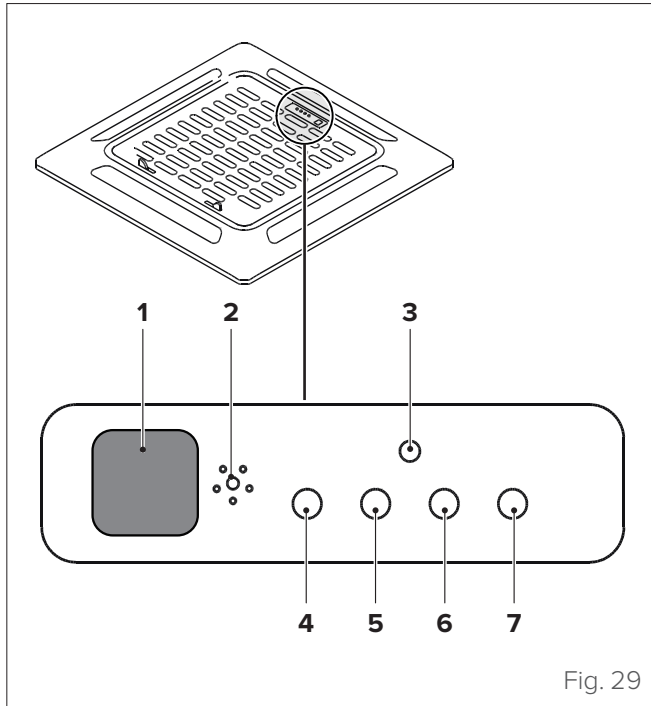

Fig. 29

- 1 Infrared receiver
- 2 Acoustic signal
- 3 Manual button
- 4 Operation indicator
- 5 Timer light
- 6 PRE-DEF indicator (preheating/defrosting)
- 7 Alarm indicator

- **MANUAL button:** This button is used to select the operating mode in the following order: AUTO, FORCED COOL, OFF.
- **Forced Cooling Mode:** In FORCED COOL mode, the operation light flashes. The system operates with the fan at high speed for 30 minutes, then switches to AUTO mode. During this operating cycle, the remote control is disabled.
- **OFF Mode:** When the panel is off (OFF mode), the unit turns off and the remote control starts working again.

3.3 Other functions

– Default settings

When the air conditioner restarts after a power failure, the factory default settings are restored (AUTO mode, AUTO fan speed, 24°C). These conditions can be different to those set on the remote control and on the unit's panel. Use the remote control to adjust the operating conditions.

– Automatic restart

If the power supply to the unit is interrupted, the unit will automatically restart with the last settings when it is restored.

– Memory of the ventilation slits angle

When the unit is turned on, the ventilation slits automatically return to the last set angle.

– Detection of refrigerant leaks

The indoor unit automatically displays "EC" when it detects a refrigerant leak.



WARNING

For a detailed explanation of the unit's advanced features (such as TURBO mode and self-cleaning functions), refer to the **Remote Control Manual**.

3.4 Remote control

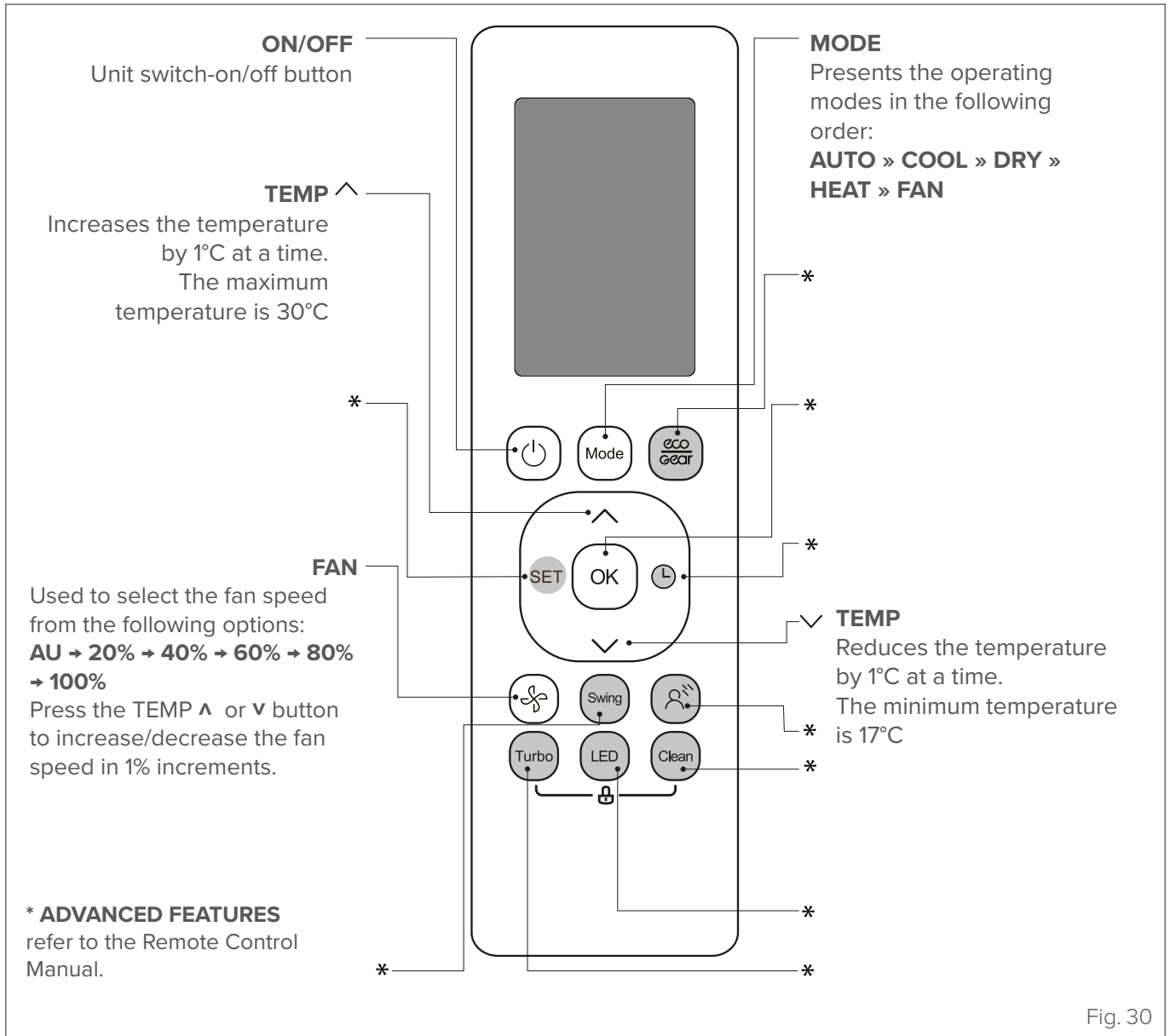

3.5 Operation

For optimum performance in cooling, heating and dehumidification modes, use the unit within the temperature ranges below. If the air conditioner is used outside of these ranges, some protective functions may trip and cause suboptimal operation.

	Cooling mode	Heating Mode	Dehumidification Mode
Room temperature	17°C ÷ 32°C	0°C ÷ 30°C	10°C ÷ 32°C
Outdoor temperature	-15°C ÷ 50°C	-15°C ÷ 24°	0°C ÷ 50°C

To further optimise unit performance, take the following steps:

- Keep doors and windows closed.
- Limit power consumption using the ON TIMER and OFF TIMER.
- Avoid obstructing air inlets or outlets.
- Inspect and clean the filters regularly.

4 MAINTENANCE

It is good practice to periodically clean both the internal and external parts of the appliance. This guarantees its proper functioning and durability.

Carry out periodic maintenance of the appliance in accordance with the regulations in force.

Maintenance must be carried out by qualified technical personnel.

4.1 Cleaning the indoor unit



ATTENTION ELECTRIC DANGER

- Before cleaning or maintenance, always turn off the air conditioner and disconnect it from the power supply.
- DO NOT replace blown fuses with fuses of different amps because this could damage the circuit or cause a fire hazard.
- Check that all cables are connected correctly. Incorrectly connecting cables can create a fire or electrocution risk.



CAUTION

- Use only a soft, dry cloth to clean the unit. If the unit is particularly dirty, you can use a cloth moistened in warm water.
- Check that the drain pipe is installed according to the instructions. If it is not, water leaks may occur resulting in material damage and fire and electrocution risks.



IT IS PROHIBITED TO

- use chemicals or chemically treated cloths to clean the unit;
- use benzene, thinners, polishing powders or other solvents to clean the unit. These substances can cause cracking or deformation of the plastic surface;
- use water at temperatures above 40°C to clean the front panel. Very hot water can cause the panel to deform or discolour.

4.2 Cleaning the air filter

The filter stops dust and other particles from entering the indoor unit. A build-up of dust can reduce the efficiency of the air conditioner. For optimal efficiency, clean the air filter every two weeks or, if the zone is very dusty, more frequently. If the filter is very clogged and cannot be perfectly cleaned, it is advisable to replace it.



WARNING

It can be dangerous to remove and clean the filter. Disassembly and maintenance operations must be carried out by certified technical personnel.



CAUTION DANGER

When removing the filter, avoid touching the metal parts of the unit. Sharp metal edges can be sharp.



IT IS PROHIBITED TO

dry the filter by exposing it to direct sunlight. The filter may shrink

- 1 Unlock the grille by pushing the two catches towards the centre at the same time.
- 2 Disconnect the display cable from the electrical panel on the main body.

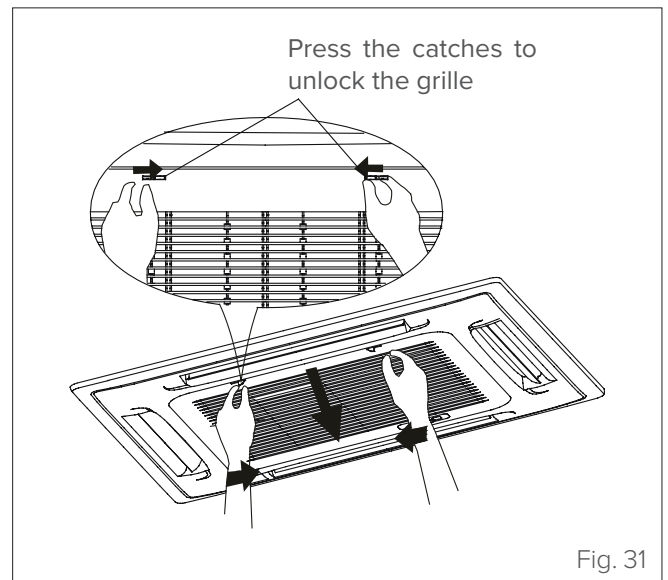

- 3 Detach the grille from the main unit by tilting it 45°, lifting it slightly and then pulling it forward.

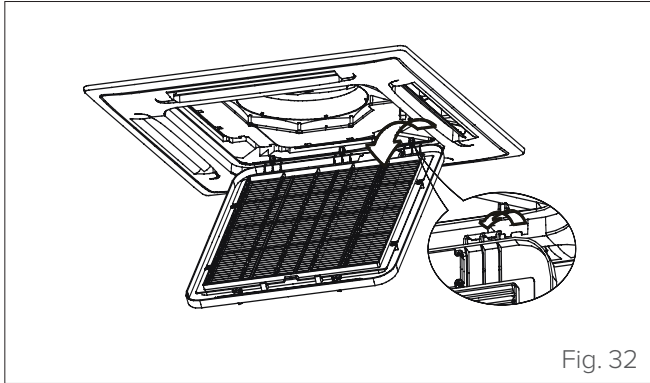

Fig. 32

- 4 Remove the air filter.
- 5 Clean the air filter with a vacuum cleaner or wash it with warm water and a mild detergent.
- If you use a vacuum cleaner, put the inlet side facing the vacuum cleaner.

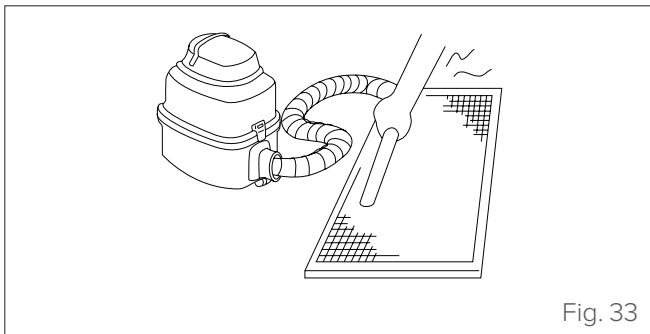

Fig. 33

- If you use water, the inlet side must face downwards, in the opposite direction to the water flow.

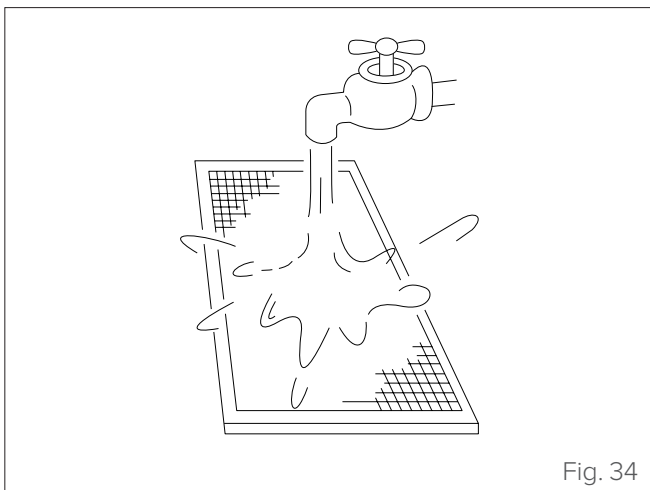

Fig. 34

- 6 Rinse the filter with clean water and let it dry in a cool, dry place, away from direct sunlight.
- 7 Once dry, reinsert the filter into the indoor unit.
- 8 Refit the front grille and reconnect the display cable to the electrical panel on the main body.

4.3 Cleaning the outdoor unit

If the battery in the outdoor unit is clogged, remove the leaves and debris and then remove the dust with a jet of air or water.

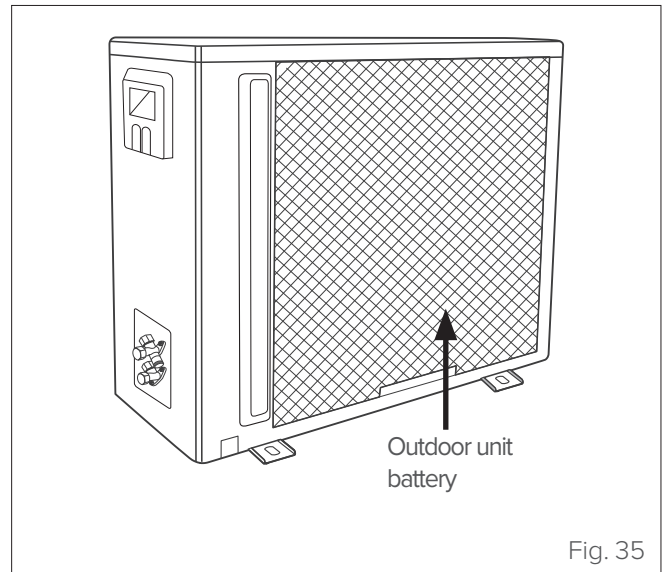

Fig. 35

4.4 Repairing refrigerant leaks

If there is a refrigerant leak, “EC” will appear on the LCD display and the LED will flash.



CAUTION DANGER

- If there is a refrigerant leak, turn the air conditioner and any other fuel heating device off, ventilate the room and contact your local dealer. The refrigerant is toxic and flammable. DO NOT use the air conditioner until the leak has been repaired.
- If the air conditioner is to be installed in a small room, necessary measures must be taken to prevent the concentration of refrigerant in the room from exceeding the safety limit in the event of leaks. An excessive concentration of refrigerant can cause serious harm to health and be a serious risk to safety.

4.5 Extended periods of inactivity

If you do not plan to use the air conditioner for an extended period of time, proceed as follows:

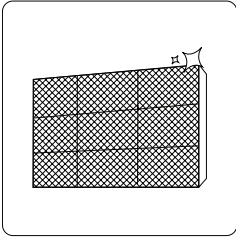

Clean all filters

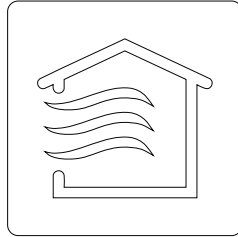

Activate the Ventilation mode until the unit is completely dry (at least 12 hours)

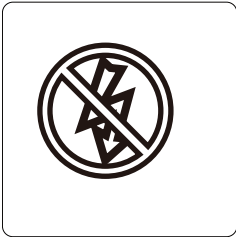

Turn off the unit and disconnect it from the mains power supply

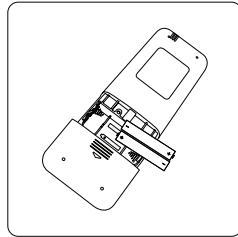

Remove the batteries from the remote control

4.6 Maintenance at the start of the season

After a long period of non-use, or before a period of frequent use, proceed as follows:

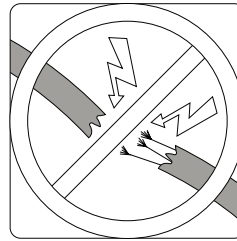

Check that the cables are intact

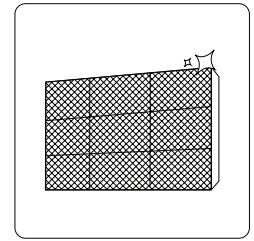

Clean all filters



Check that there are no leaks

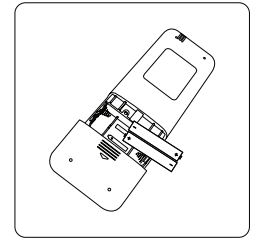

Replace batteries

Remove all obstacles that could block the openings of the indoor and outdoor units.

Clean the air filter and the front grille of the indoor unit. Refit the clean and dry air filter in its original position.

Turn the main power switch on at least 12 hours before switching the unit on.

4.7 Troubleshooting



CAUTION DANGER

If any of the following conditions occur, turn the unit off immediately.

- The power cable is damaged or unusually hot.
- You can smell burning.
- The unit makes loud or abnormal noises.
- A fuse blows or the circuit breaker trips frequently.
- Water or other substance have fallen into the unit, or water or other substance have leaked from the unit.

DON'T TRY TO SOLVE THE PROBLEM YOURSELF. IMMEDIATELY CONTACT AN AUTHORISED SERVICE CENTRE.

4.7.1 Common problems

The problems described below do not represent malfunctions and, in most cases, do not require repair.

Problem	Possible causes
The unit does not turn on when the ON/OFF button is pressed	<ul style="list-style-type: none"> - The unit has a 3-minute delay protection feature that prevents overloading. The unit cannot be restarted until three minutes have elapsed since shutdown. - If the operation light and the PRE-DEF indicators (Preheating/Defrosting) are on, this means that the outdoor temperature is too low and the anti-cold function has been started to defrost the unit.
The unit switches from Cooling/Heating mode to Ventilation mode	<ul style="list-style-type: none"> - The unit can change operating mode to prevent frost formation. As the temperature rises, the unit will return to the previously set mode. - The set temperature has been reached and the compressor has switched off. The unit will continue to operate in response to temperature changes.
The indoor unit emits a white haze	<ul style="list-style-type: none"> - In humid regions, a marked difference in temperature between the air in the room and the air conditioning can cause a white mist to form.
Both the indoor and outdoor units emit a white haze	<ul style="list-style-type: none"> - When the unit restarts in Heating mode after a defrost cycle, it may emit a white haze due to moisture generated by the defrosting process.
The indoor unit is noisy	<ul style="list-style-type: none"> - An air current noise is heard when the ventilation slit returns to its original position. - You will hear a crackling sound after the Heating mode is activated due to the expansion and contraction of the plastic parts of the unit.
Both the indoor and outdoor units are noisy	<ul style="list-style-type: none"> - Slight hissing during operation: this noise is normal and is due to the circulation of refrigerant gas in the indoor and outdoor units. - Slight hissing when the system starts up, immediately after shutdown or during defrosting: this noise is normal and is caused by stopping or changing the direction of the refrigerant gas. - Cracking: due to normal expansion and contraction of plastic and metal parts caused by temperature changes during operation.
The outdoor unit is noisy	<ul style="list-style-type: none"> - The unit emits various noises depending on the operating mode in use.
Indoor or outdoor unit emits dust	<ul style="list-style-type: none"> - During a long period of non-use, dust may accumulate on the unit and be emitted when it is turned on again. This problem can be partly solved by covering the unit during prolonged periods of inactivity.
The unit smells bad	<ul style="list-style-type: none"> - The unit may absorb ambient odours (furniture, cooking, cigarettes, etc.) and emit them during operation. - Mold has formed on the unit's filters and must be removed.
The fan of the outdoor unit is not working	<ul style="list-style-type: none"> - During operation, fan speed is controlled to optimise the operation of the air conditioner.
Operation is erratic or unpredictable, or the unit does not respond to commands	<p>Interference from mobile phone repeaters and remote amplifiers may cause the unit to malfunction.</p> <p>In this case, try to solve the problem as follows:</p> <ul style="list-style-type: none"> - Disconnect the unit from the power mains and then reconnect it. - Press the ON/OFF button on the remote control to restart operation.

NOTE: if the problem persists, contact your local dealer or nearest service centre, providing a detailed description of the malfunction and specifying the model code.

4.7.2 Anomalies and remedies

If problems occur, please check the following before contacting a service centre.

Anomalies	Possible causes	Remedies
Unsatisfactory cooling performance	The set temperature may be higher than the room temperature	Set a lower temperature
	The heat exchanger of the indoor or outdoor unit is dirty	Clean the heat exchanger (Service Centre)
	The air filter is dirty	Remove the filter and clean it following instructions
	The air inlet or outlet of the indoor or outdoor unit is blocked	Turn off the unit, remove the cause of the obstruction and turn the air conditioner on again
	Open doors and windows	Close doors and windows when using the unit
	Sunlight produces excessive heat	Close curtains and windows during the hottest hours or when the sun is brightest
	Too many heat sources in the room (people, computers, electronic devices, etc.)	Reduce heat sources
	Low refrigerant level due to leakage or prolonged use	Check for leaks, reseal the system if necessary and refill the refrigerant (Service Centre)
The SILENCE function is active	The SILENCE function can reduce product performance by reducing the frequency of operation. Deactivate the SILENCE function.	
The unit does not work	Power failure	Wait for power to be restored
	The unit is turned off	Switch on the device
	The fuse is blown	Replace the fuse (Service Centre)
	Remote control batteries are low	Replace batteries
	Protection function with 3-minute delay is active	Wait three minutes before restarting the unit
The unit starts or stops frequently	The timer is active	Deactivate the timer
	The amount of refrigerant in the system is excessive or insufficient	Check for leaks and top up the refrigerant (Service Centre)
	Incompressible gas has entered or moisture has penetrated the system.	Evacuate the system and recharge the refrigerant (Service Centre)
	The compressor is faulty	Replace the compressor (Service Centre)
Unsatisfactory heating performance	The voltage is too high or too low	Install a voltage controller (Service Centre)
	The outside temperature is extremely low	Using an auxiliary heating appliance
	Cold air enters through doors and windows	Close doors and windows when using the unit
The indicator lights continue to flash An error code appears on the display of the indoor unit: • E0, E1, E2... • P1, P2, P3... • F1, F2, F3...	Low refrigerant level due to leakage or prolonged use	Check for leaks, reseal the system if necessary and refill the refrigerant (Service Centre)
	The unit may stop or continue to operate properly. If the indicator lights continue to flash or error codes are displayed, wait approximately 10 minutes. The problem may solve itself. If not, disconnect the unit from the power mains and reconnect it. Turn on the unit. If the problem persists, disconnect the unit from the power supply and contact the nearest service centre.	

NOTE: if, after performing the above checks and diagnostic procedures, the problem persists, turn the unit off immediately and contact an authorised service centre.

4.8 Error codes displayed on the indoor unit display

Error code	Cause	Timer light
EH 00 / EH 0A	Indoor unit EEPROM parameter error	OFF
EL 01	Indoor / outdoor unit communication error	OFF
EH 03	The indoor fan speed is operating outside of the normal range(for some models)	OFF
EH 60	Indoor room temperature sensor T1 is in open circuit or has short circuited	OFF
EH 61	Evaporator coil temperature sensor T2 is in open circuit or has short circuited	OFF
EL 0C	Refrigerant Leakage Detection(for some models)	OFF
EH 0b	Communication error between indoor two chips	OFF
EH 0E	Water-level alarm malfunction	OFF
EC 53	Outdoor room temperature sensor T4 is in open circuit or has short circuited	OFF
EC 52	Condenser coil temperature sensor T3 is in open circuit or has short circuited	OFF
EC 54	Compressor discharge temperature sensor TP is in open circuit or has short circuited	OFF
EC 56	Evaporator coil outlet temperature sensor T2B is in open circuit or has short circuited(for free-match indoor units)	OFF
EC 51	Outdoor unit EEPROM parameter error	ON
EC 07	The outdoor fan speed is operating outside of the normal range(for some models)	OFF
PC 00	IPM malfunction or IGBT over-strong current protection	FLASH
PC 01	Over voltage or over low voltage protection	FLASH
PC 02	Top temperature protection of compressor or High temperature protection of IPM module	FLASH
PC 04	Inverter compressor drive error	FLASH
PC 03	High pressure protection or low pressure protection (for some models)	FLASH
EC 0d	Outdoor unit malfunction	OFF
--	Indoor units mode conflict(match with multi outdoor unit) (for some models)	ON

NOTE: To case of an alarm, the operation light (flashes)

ERROR CODES DISPLAYED ON THE REMOTE CONTROL

Use the “Query mode” function on the remote control to display the alarms (see: technical manual special modes).

Error code	Description
EH 00 / EH 0A	Indoor unit EEPROM parameter error
EL 01	Indoor / outdoor unit communication error
EH bA	Communication error between indoor unit and indoor external fan module
EH 30	Parameters error of indoor external fan
EH 35	Phase failure of indoor external fan
EH 36	Indoor external fan current sampling bias fault
EH 37	Indoor external fan zero speed failure
EH 38	Indoor external fan stall failure
EH 39	Out of step failure of indoor external fan
EH 3A	Low voltage protection of indoor external fan DC bus
EH 3b	Indoor external fan DC bus voltage is too high fault
EH 3E	Indoor external fan overcurrent fault
EH 3F	Indoor external fan module protection/hardware overcurrent protection
EH 03	The indoor fan speed is operating outside of the normal range
EC 51	Outdoor unit EEPROM parameter error
EC 52	Condenser coil temperature sensor T3 is in open circuit or has short circuited
EC 53	Outdoor room temperature sensor T4 is in open circuit or has short circuited
EC 54	Compressor discharge temperature sensor TP is in open circuit or has short circuited
EC 55	IGBT temperature sensor TH is in open circuit or has short circuited
EC 0d	Outdoor unit malfunction
Eh 60	Indoor room temperature sensor T1 is in open circuit or has short circuited
Eh 61	Evaporator coil temperature sensor T2 is in open circuit or has short circuited
EC 71	Outdoor external fan overcurrent fault
EC 75	Outdoor external fan module protection/hardware overcurrent protection
EC 72	Outdoor external fan phase failure
EC 74	Outdoor external fan current sampling bias fault
EC 73	Zero speed failure of outdoor unit DC fan
EC 07	The outdoor fan speed is operating outside of the normal range(
EL 0C	Refrigerant leak detected
EH 0b	Communication error between indoor two chips
EH 0E	Water-level alarm malfunction
PC 00	IPM malfunction or IGBT over-strong current protection
PC 10	Over low voltage protection
PC 11	Over voltage protection
PC 12	DC voltage protection

PC 02	Top temperature protection of compressor or High temperature protection of IPM module
PC 40	Communication error between outdoor main chip and compressor driven chip
PC 41	Current Input detection protection
PC 42	Compressor start error
PC 43	Lack of phase (3 phase) protection
PC 44	Outdoor unit zero speed protection
PC 45	341PWM error
PC 46	Compressor speed malfunction
PC 49	Compressor over current protection
PC 06	Compressor discharge temperature protection
PC 08	Outdoor current protection
PH 09	Anti-cold air in heating mode
PC 0f	PFC module malfunction
PC 30	System overpressure protection
PC 31	System pressure is too low protection
PC 03	Pressure protection
PC 0I	Outdoor low ambient temperature protection
PH 90	Evaporator coil temperature over high protection
PH 91	Evaporator coil temperature over low Protection
PC 0A	Condenser high temperature protection
PH 0C	Indoor unit humidity sensor failure
LH 00	Frequency limit caused by T2
LH 30	Indoor external fan current limit
LH 31	Indoor external fan voltage limit
LC 01	Frequency limit caused by T3
LC 02	Frequency limit caused by TP
LC 05	Frequency limit caused by voltage
LC 03	Frequency limit caused by current
LC 06	Frequency limit caused by PFC
LC 30	Frequency limit caused by high pressure
LC 31	Frequency limit caused by low pressure
LH 07	Frequency limit caused by remote controller
--	Indoor units mode conflict(match with multi outdoor unit)

5 DISPOSAL

The manufacturer is registered on the National EEE Register, in compliance with implementation of Directive 2012/19/EU and pertinent national regulations on electrical and electronic equipment waste.

This Directive requires electrical and electronic equipment to be disposed of properly.

Equipment bearing the crossed-out wheelie bin symbol must be disposed of separately at the end of its lifecycle to prevent damage to human health and to the environment.

Electrical and electronic equipment must be disposed of together with all of its parts.

To dispose of “household” electrical and electronic equipment, the manufacturer recommends contacting an authorised dealer or an authorised ecological site.

“Professional” electrical and electronic equipment must be disposed of by authorised personnel through established waste disposal authorities around the country.

In this regard, here is the definition of household WEEE and professional WEEE.

WEEE from private households: WEEE originating from private households and WEEE which comes from commercial, industrial, institutional and other sources which, because of its nature and quantity, is similar to that from private households. Subject to the nature and quantity, where the waste from EEE was likely to have been used by both a private household and users of other than private households, it will be classed as private household WEEE;

Professional WEEE: all WEEE which comes from something other than private households.

This equipment may contain:

- refrigerant gas, the entire contents of which must be recovered in suitable containers by specialised personnel with the necessary qualifications;
- lubrication oil contained in compressors and in the refrigeration circuit to be collected;
- mixtures with antifreeze in the water circuit, the contents of which are to be collected;
- mechanical and electrical parts to be separated and disposed of as authorised.

When the components to be replaced for maintenance purposes are removed or when the entire unit reaches the end of its life and needs to be removed from the installation, waste should be separated by its nature and disposed of by authorised personnel at existing collection centres.

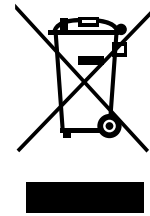

6 ATTACHMENTS

6.1 Indoor unit wiring diagrams

SERIES	SIZE
IB3-XY	27M - 53M

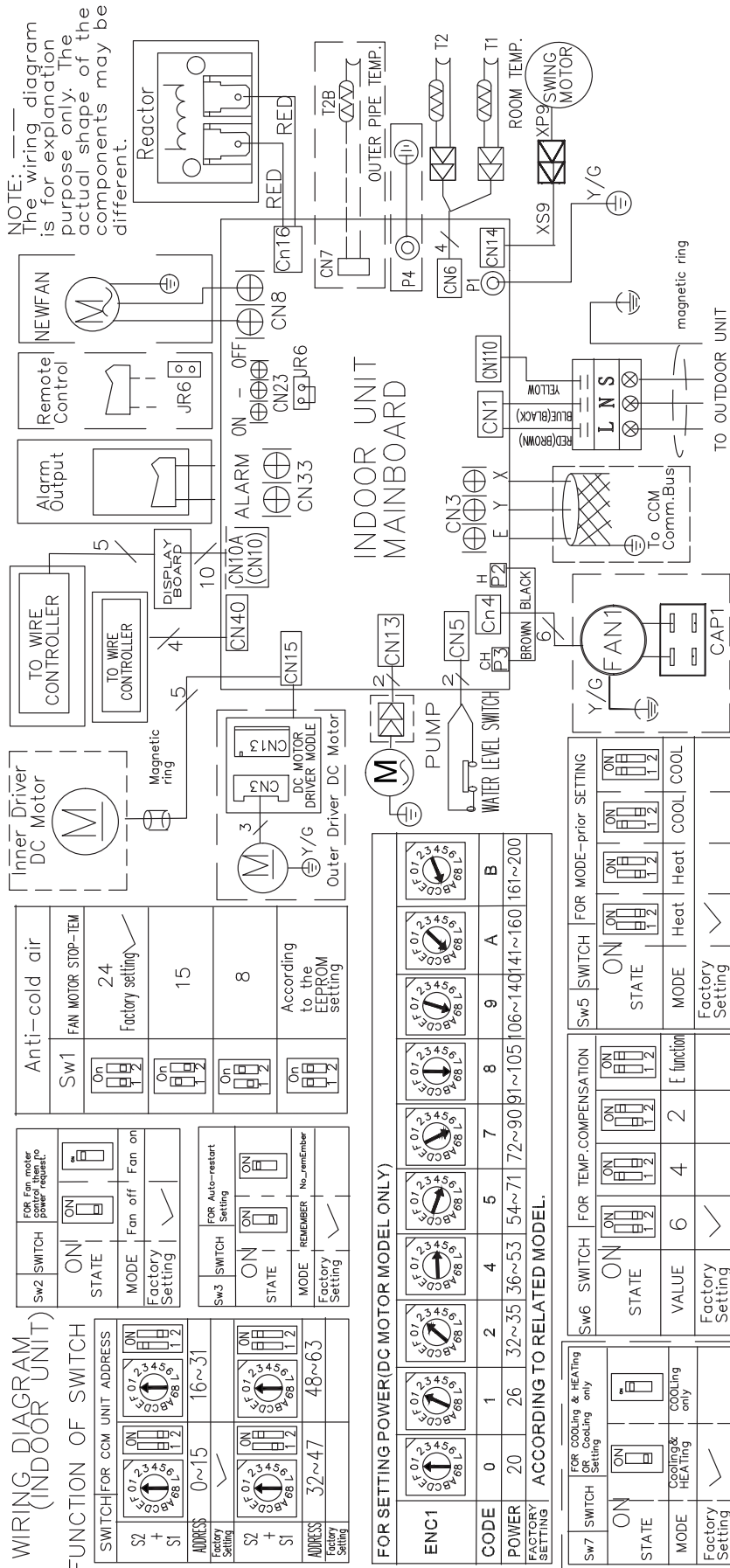

6.2 Declaration of conformity



DECLARATION OF CONFORMITY EU

DICHIARAZIONE DI CONFORMITÀ UE
 KONFORMITÄTSEKRLÄRUNG EU
 DECLARATION DE CONFORMITE EU
 DECLARACIÓN DE CONFORMIDAD EU

WE DECLARE UNDER OUR SOLE RESPONSIBILITY THAT THE MACHINE

DICHIARIAMO SOTTO LA NOSTRA SOLA RESPONSABILITÀ CHE LA MACCHINA
 WIR ERKLÄREN EIGENVERANTWORTLICH, DASS DIE MASCHINE
 NOUS DÉCLARONS SOUS NOTRE SEULE RESPONSABILITÉ QUE LA MACHINE
 EL FABRICANTE DECLARA BAJO SU EXCLUSIVA RESPONSABILIDAD QUE LA MÁQUINA

CATEGORY	DIRECT EXPANSION TERMINALS - Heat pump
CATEGORIA	TERMINALI AD ESPANSIONE DIRETTA - Pompa di calore
KATEGORIE	DIREKTVERDAMPFUNGSGERÄTE - Wärmepumpe
CATEGORIE	TERMINAUX À DÉTENTE DIRECTE - Pompe à chaleur
CATEGORIA	TERMINALES POR EXPANSIÓN DIRECTA - Bomba de calor

TYPE / TIPO / TYP / TYPE / TIPO

IB3-XY 27M IB3-XY 35M IB3-XY 53M

- **COMPLIES WITH THE FOLLOWING EEC DIRECTIVES, INCLUDING THE MOST RECENT AMENDMENTS, AND THE RELEVANT NATIONAL HARMONISATION LEGISLATION CURRENTLY IN FORCE:**
- RISULTA IN CONFORMITÀ CON QUANTO PREVISTO DALLE SEGUENTI DIRETTIVE CEE, COMPRESE LE ULTIME MODIFICHE, E CON LA RELATIVA LEGISLAZIONE NAZIONALE DI RECEPIMENTO:
- DEN IN DEN FOLGENDEN EWG-RICHTLINIEN VORGEGEHENEN VORSCHRIFTEN, EINSCHLIEßLICH DER LETZTEN ÄNDERUNGEN, SOWIE DEN ANGEWANDTEN LANDESGESETZEN ENTSPRICHT:
- EST CONFORME AUX DIRECTIVES CEE SUIVANTES, Y COMPRIS LES DERNIÈRES MODIFICATIONS, ET À LA LÉGISLATION NATIONALE D'ACCUEIL CORRESPONDANTE:
- ES CONFORME A LAS SIGUIENTES DIRECTIVAS CEE, INCLUIDAS LAS ÚLTIMAS MODIFICACIONES, Y A LA RELATIVA LEGISLACIÓN NACIONAL DE RECEPCIÓN:

- 2014/35/EC** **low voltage directive**
 direttiva bassa tensione
 Bestimmungen der Niederspannungsrichtlinie
 directive basse tension
 directiva de baja tensión
- 2014/30/UE** **electromagnetic compatibility**
 compatibilità elettromagnetica
 Elektromagnetische Verträglichkeit
 compatibilité électromagnétique
 compatibilidad electromagnética
- 2009/125/CE** **Ecodesign /Progettazione ecocompatibile / Ecodesign / Éco-conception / Ecodiseño**
- 2011/65/UE** **2015/863/UE** **RoHs**

-Unit manufactured and tested according to the followings Standards:	EN 60335-2-40 :2003+A1+A11+A12+A2+A13
-Unità costruita e collaudata in conformità alle seguenti Normative:	EN 60335-1 :2012+A11+A13+A14+A2 EN 62233 :2008
-Unité construite et testée en conformité avec les Réglementations suivantes	EN 55014-1 :2017+A11 :2020 EN 55014-2 :2015
-Unidad construida y probada de acuerdo con las siguientes Normativas	EN IEC 61000-3-2 :2019 EN 61000-3-3 :2013+A1 :2019
-Gebautes und geprüftes Gerät nach folgenden Normen	EN 62321-1 :2013 EN 62321-2 :2014 EN 62321-3-1 :2014
	EN 62321-4 :2014 EN 62321-5 :2014 EN 62321-6 :2015
	EN 62321-7-1 :2015 EN 62321 :2009

-Responsible to constitute the technical file is the company n° 00708410253 and registered at the Chamber of Commerce of Belluno Italy
 -Responsabile a costituire il fascicolo tecnico è la società n° 00708410253 registrata presso la Camera di Commercio di Belluno Italia
 -Verantwortliche für die technischen Unterlagen zusammenstellen n° 00708410253 ist das Unternehmen bei der Handelskammer von Belluno Italien registriert
 -Responsable pour compiler le dossier technique est la société n°00708410253 enregistrée à la Chambre de Commerce de Belluno en Italie
 -Encargado de elaborar el expediente técnico es la empresa N ° 00708410253 registrada en la Cámara de Comercio de Belluno Italia

FELTRE, <u>20/09/2021</u>	NAME / NOME / VORNAME / PRÉNOM / NOMBRE	
	SURNAME / COGNOME / ZUNAME / NOM / APELLIDOS	STEFANO BELLÒ
	COMPANY POSITION / POSIZIONE / BETRIEBSPOSITION / FONCTION / CARGO	LEGALE RAPPRESENTANTE

FOR 30 YEARS WE HAVE BEEN OFFERING
SOLUTIONS FOR SUSTAINABLE COMFORT
THE WELL-BEING OF PEOPLE AND
THE ENVIRONMENT

www.clivet.com

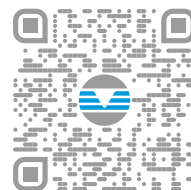

sales and service



CLIVET SPA
Via Camp Lonc 25, Z.I. Villapaiera
32032 Feltre (BL) - Italy
Tel. +39 0439 3131 - Fax +39 0439 313300
info@clivet.it

MideaGroup
humanizing technology