

ELFOFresh EVO

CPAN-YIN Size2



MANUAL
FOR INSTALLATION,
USE AND MAINTENANCE

en

Change living home

R-32

M05Q00001-04 05-2024



ROMANIAN



BULGARIAN



SLOVENIAN



HRVATSKI

Dear Customer,



We congratulate you on choosing an ELFOSystem product, the air conditioning system at annual cycle that offers the possibility in a sole system of meeting all the heating, conditioning and domestic hot water needs, purifies and renews the air .

Clivet is being working for years to offer systems able to assure the maximum comfort for long time with high reliability, efficiency , quality and safety. The target of the company is to offer advanced systems, that assure the best comfort, reduce the energy consumption, the installation and maintenance costs for all the life-cycle of the system.

With this manual, we want to give you information that are useful in all the phases: from the reception, to the installation and use until the disposal so that a system so advanced offers the best procedure of installation and use.

Best regards and have a nice reading !

CLIVET Spa

	Safety considerations	5
	1 General	9
	2 Reception	13
	3 Positioning	15
	4 Water connections	21
	5 Aeraulic connections	22
	6 Electric connections	27
	7 Start-up	29
	8 Control	34
	9 Maintenance	59
	10 Decommissioning	69
	11 Residual risks	70
	12 Technical date	71
	13 ELFOAir	76

Pay particular attention to:



INSTALLER use



USER use

The data contained in this manual is not binding and may be changed by the manufacturer without prior notice.
All reproduction, even partial, is prohibited. © Copyright - CLIVET S.p.A. - Feltre (BL) - Italy

Rapid guide

A Consider sound emissions

Avoid installations next to bedrooms

For details see the manual sections

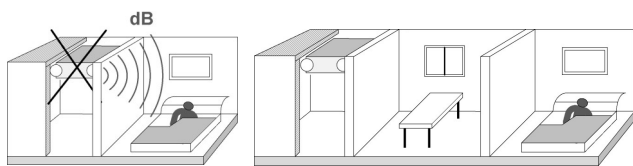

Install in a local or compartment where the temperature can't drop below 10° C.

B Functional spaces

Respect the spaces to conduct normal and extraordinary maintenance

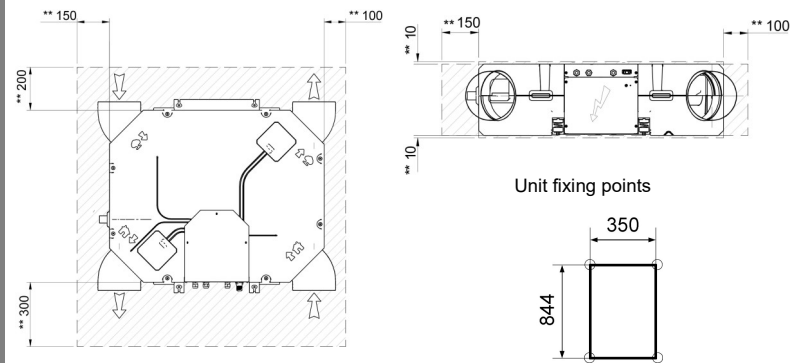
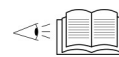

** minimum service clearance

Install supplied antivibration

C Aeraulic ducts

Dimensions connections

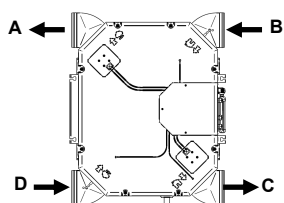

Avoid air bypass

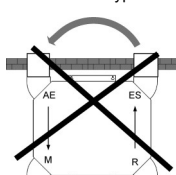

Anti-vibration joint when used rigid pipes

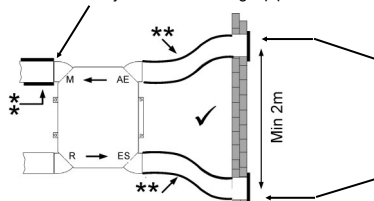

** Insulated ducts

Safety grilles

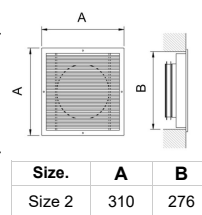

Avoid tight bends

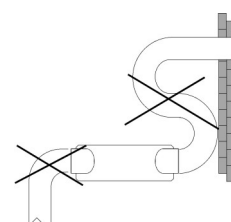

A	Air expulsion	Ø 200 mm
B	Ambient air return	Ø 200 mm
C	Ambient air distribution	Ø 200 mm
D	Fresh air intake	Ø 200 mm

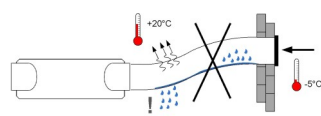
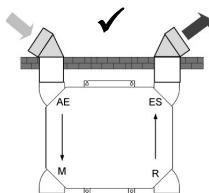

Should not be tilted towards unit

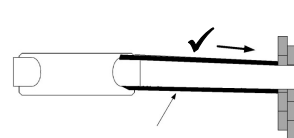

Insulated ducts

D Condensate discharge

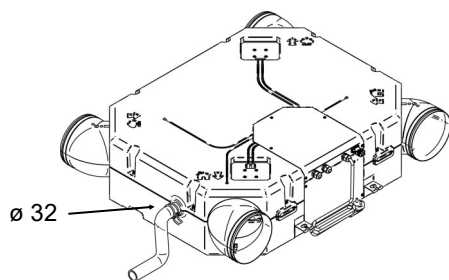

Siphon

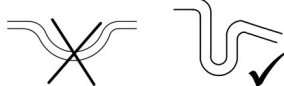

E Electric connections



Customer connections

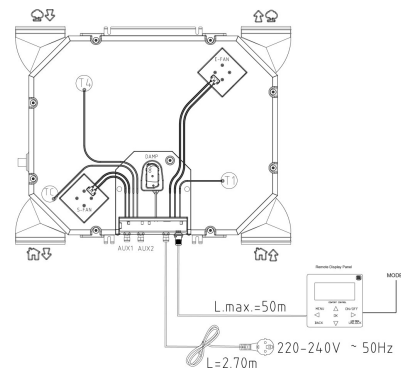
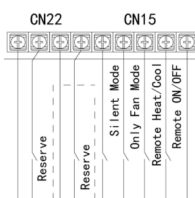

F HMI ambient keyboard

Connect the ambient keyboard to the main board



Connections
Cable 5x0,75 mm² shielded
Max. length 50m



HMI

Positions

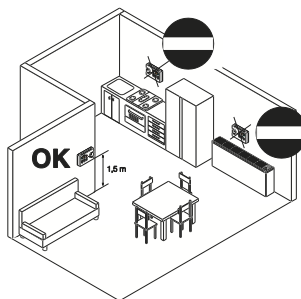

The keyboard must be placed:

- at a height of 150 cm
- preferably on an internal wall
- Positions to avoid:
- next to heat sources
- points exposed to direct sunlight
- Etc....

The precautions in this manual are divided as indicated on the side. They are important, so make sure you follow them closely.

Please read these instructions carefully before installing.

Keep this manual handy for future reference.

This unit contains fluorinated gases. For specific information on gas types and quantities, please refer to the plate found on the unit.

Please contact your dealer for future assistance.

Meaning of the symbols DANGER, WARNING, CAUTION and NOTE

DANGER

⇒ It indicates a situation of imminent danger that, if not avoided, will cause death or serious lesions.

WARNING

⇒ It indicates a potentially dangerous situation that, if not avoided, may cause death or serious lesions.

CAUTION

⇒ It indicates a potentially dangerous situation that, if not avoided, may cause slight or moderate injury. Also used to warn against unsafe practices.

NOTE

⇒ It indicates situation that may cause accidental damage to the equipment or property.

DANGER

⇒ An incorrect installation of equipment or accessories may provoke electric shocks, short circuits, leaks, fire or other damages to the equipment. Make sure you

only use accessories provided by the supplier - which are designed specifically for the equipment - and make sure they are installed by a professional.

⇒ *All activities described in this manual must be performed by authorised technicians. Make sure to wear suitable personal protection such as gloves and safety goggles while installing the unit or performing maintenance operations.*

⇒ *Switch off the power switch before touching electrical components and terminals.*

⇒ *When the service panels are removed, the live parts can easily be touched by mistake.*

⇒ *Never leave the unit unattended during installation or maintenance operations while the service panel is removed.*

⇒ *Do not touch the water pipes during and after performing welding or junction work as the pipes may be very hot and you may burn your hands. To avoid lesions, wait until the pipes return to a normal temperature or make sure you are wearing protective gloves.*

⇒ *Do not touch any switch with wet hands. Touching a switch with wet hands may lead to electric shock.*

WARNING

⇒ *Maintenance operations must be performed as recommended by the manufacturer. Maintenance and reparation operations requiring the assistance from specialized personnel must be performed under the supervision of the person competent as regards flammable refrigerants.*

- ⇒ *Tear and dispose of plastic bags so that children may not play with them. Children playing with plastic bags risk choking.*
- ⇒ *Some products use PP packaging straps. Do not pull the straps or use them to lift or move the product. It may be dangerous should the straps break.*
- ⇒ *Dispose safely of packaging material such as nails or other metal or wooden parts that may cause lesions.*
- ⇒ *Ask your dealer or qualified personnel to perform installation operations according to this manual. Do not install the unit yourself. An incorrect installation may cause water leaks, electric shock or fire.*
- ⇒ *Make sure to only use accessories and parts specified for installation operations. Failing to use specific parts may cause*
 - ⇒ *water leaks, electric shock, fire or the unit falling from its support.*
 - ⇒ *Install the unit on a structure that can withstand its weight. An insufficiently robust structure may lead to the unit falling causing possible lesions.*
 - ⇒ *Perform installation operations considering the possibility that strong winds, hurricanes or earthquakes may occur. Incorrect installation operations may lead to accidents caused by falling equipment.*
 - ⇒ *Make sure all electrical operations are performed by qualified personnel in accordance with the law, local regulations and this manual.*
- ⇒ *Connect the unit to a separate power supply circuit. An insufficient capacity of the power supply circuit or incorrect connections may lead to electric shock or fire.*
- ⇒ *Make sure to install an additional differential circuit-breaker against a leakage to earth compliant with the law and local regulations: omnipolar circuit breaker, at least 3 mm separation in all poles, residual current device (RCD) with a rated value not exceeding 30 mA.*
- ⇒ *Failing to install a differential circuit-breaker may lead to electric shock and fire.*
- ⇒ *Make sure all the wiring is safe. Use the specified wires and make sure terminal connections and wires are protected against the water, external forces or other phenomena. Incomplete connections or fixing may cause a fire.*
- ⇒ *When connecting the power supply, arrange the wires so that the front panel can be fixed properly. If the front panel is not in position, it may lead to terminals overheating, electric shock or fire.*
- ⇒ *People working or intervening on a cooling circuit must hold a suitable certification issued by an authorised assessment centre proving their suitability to handle refrigerants safely in compliance with a specific assessment recognised by industry associations.*
- ⇒ *After installation operations are over, verify that there are no refrigerant leaks.*
- ⇒ *Never touch the leaking refrigerant directly, as it may lead to serious frostbite injuries. Do not touch the*

refrigerant pipes during and right after functioning, as they may be hot or cold depending on the conditions of the refrigerant flowing through the pipes, compressor and other parts of the cooling circuit. Burns or frostbite may occur if you touch the refrigerant pipes. If it is necessary to touch the pipes, wait for them to return to a normal temperature or wear protective gloves and clothes.

- ⇒ Do not touch the internal parts during and immediately after functioning. Touching internal parts may cause burns. To avoid lesions, wait until the internal parts have returned to a normal temperature or, if touching them is necessary, wear protective gloves.
- ⇒ Do not pierce nor burn.
- ⇒ Be aware that refrigerants are odourless.

CAUTION

- ⇒ Place the unit on the ground.
- ⇒ The earth resistance should comply with the law and local regulations.
- ⇒ Do not connect the earth cable to gas or water mains, lightning rods or phone earth cables.
- ⇒ Incomplete earthing may cause electrical shocks.
- Gas mains: fires or explosions may occur in case of a gas leak.
- Water mains: rigid vinyl tubes are not effective.
- Lightning rods or phone earth cables: the electrical threshold can increase abnormally if hit by lightning.
- ⇒ Do not wash the unit as it may cause electric shocks or fires.

⇒ Do not install the unit in the following places:

- Where there is mineral oil, even in form of vapour. Plastic parts may deteriorate, disperse and cause water leaks.
- Where corrosive gases (such as sulphurous acid) are produced.
- Where the corrosion of copper pipes or welded parts may cause refrigerant leaks.
- Where there are devices emitting electromagnetic waves. Electromagnetic waves may disturb the control system and cause malfunctions.
- Where flammable gases may leak, or carbon fibre or flammable powders may be found in the air or where volatile flammable materials such as paint thinners or petrol are handled. These gases may cause a fire.
- Where the air contains high levels of salt, such as the seaside.
- Where the power supply voltage is subject to fluctuations, such as in factories.
- On vehicles or ships.
- Where there are acid or alkaline vapours.
- ⇒ Prior to installation, verify if the user's power supply meets the unit's installation requirements (including reliable earthing, differential circuit-breaker, component size, wire section, etc.). If the electrical installation requirements are not met, the unit cannot be installed until the electrical system is rectified.
- ⇒ Before the hydraulic connection and electrical wiring operations, verify that the installation area is safe

and without hidden dangers such as water, electricity and gas conduits.

- ⇒ *Do not touch the fins of the heat exchanger as they may cause injury.*
- ⇒ *If installing multiple units in a centralised manner, adjust the electric load on the various phases. Do not connect multiple units to the same phase of the three-phase supply.*
- ⇒ *The following subjects may use the unit if supervised or instructed on safe usage and capable of understanding the possible dangers: children who are minimum 8 years old, people with no experience or knowledge, people with limited physical, sensory or mental abilities.*
- ⇒ *Children must not play with the unit.*
- ⇒ *Cleaning and maintenance operations to be carried out by the user must not be performed by unsupervised children.*
- ⇒ *Once the installation is complete, the unit tested and functioning is normal, instruct the client as regards the use and maintenance of the unit as indicated in this manual. In addition, make sure that the manual is suitably kept for future reference.*
- ⇒ *DISPOSAL: do not dispose of this product as unsorted waste. Contact the local authorities for information on the collection systems available. If electrical equipment is disposed of in landfills, dangerous substances may infiltrate the waste water and enter the food chain, harming the health and well-being of people and animals.*

UNIT DESCRIPTION

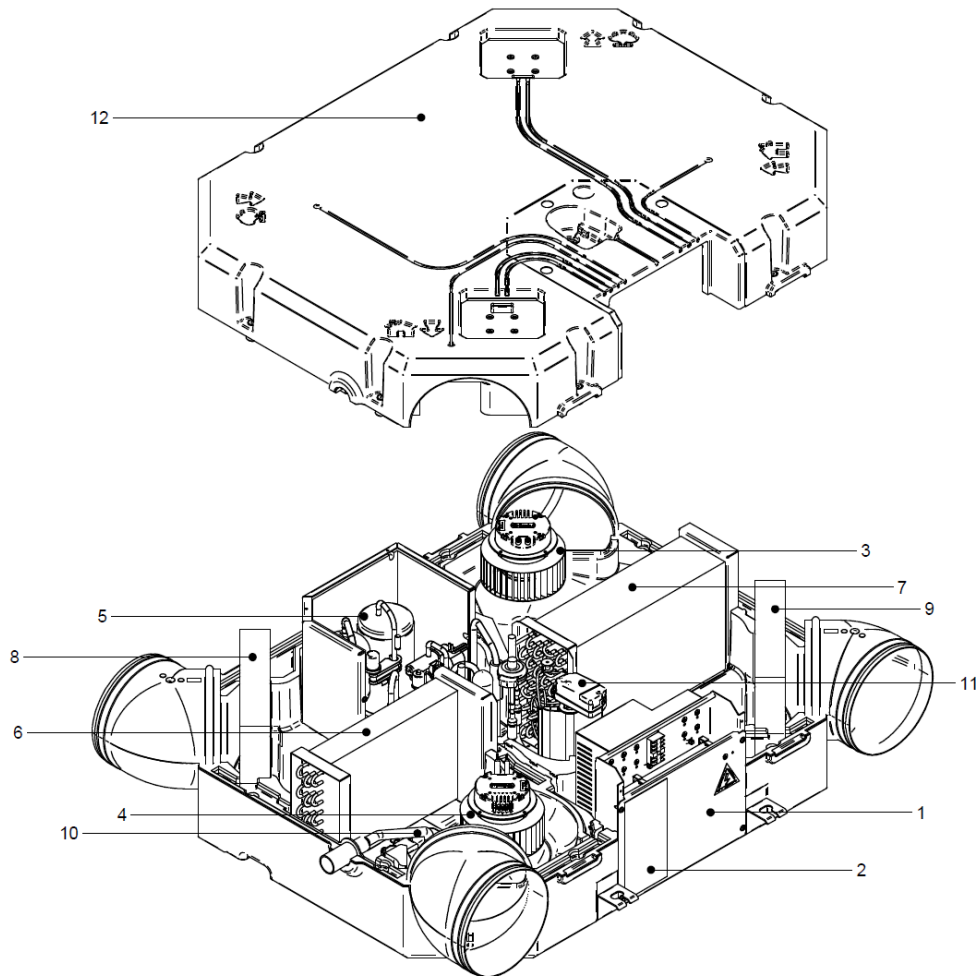

- 1 Electrical panel
- 2 Serial number label
- 3 Exhaust fan
- 4 Supply fan
- 5 Compressor
- 6 External exchanger
- 7 Internal exchanger
- 8 ambient air supply air filter
- 9 exhaust air filter
- 10 Condensate drain pump
- 11 Air shutter actuator
- 12 Upper closing housing

ACCESSORIES

ELFOAir

Is the air distribution system.
Fairing for in-view installation

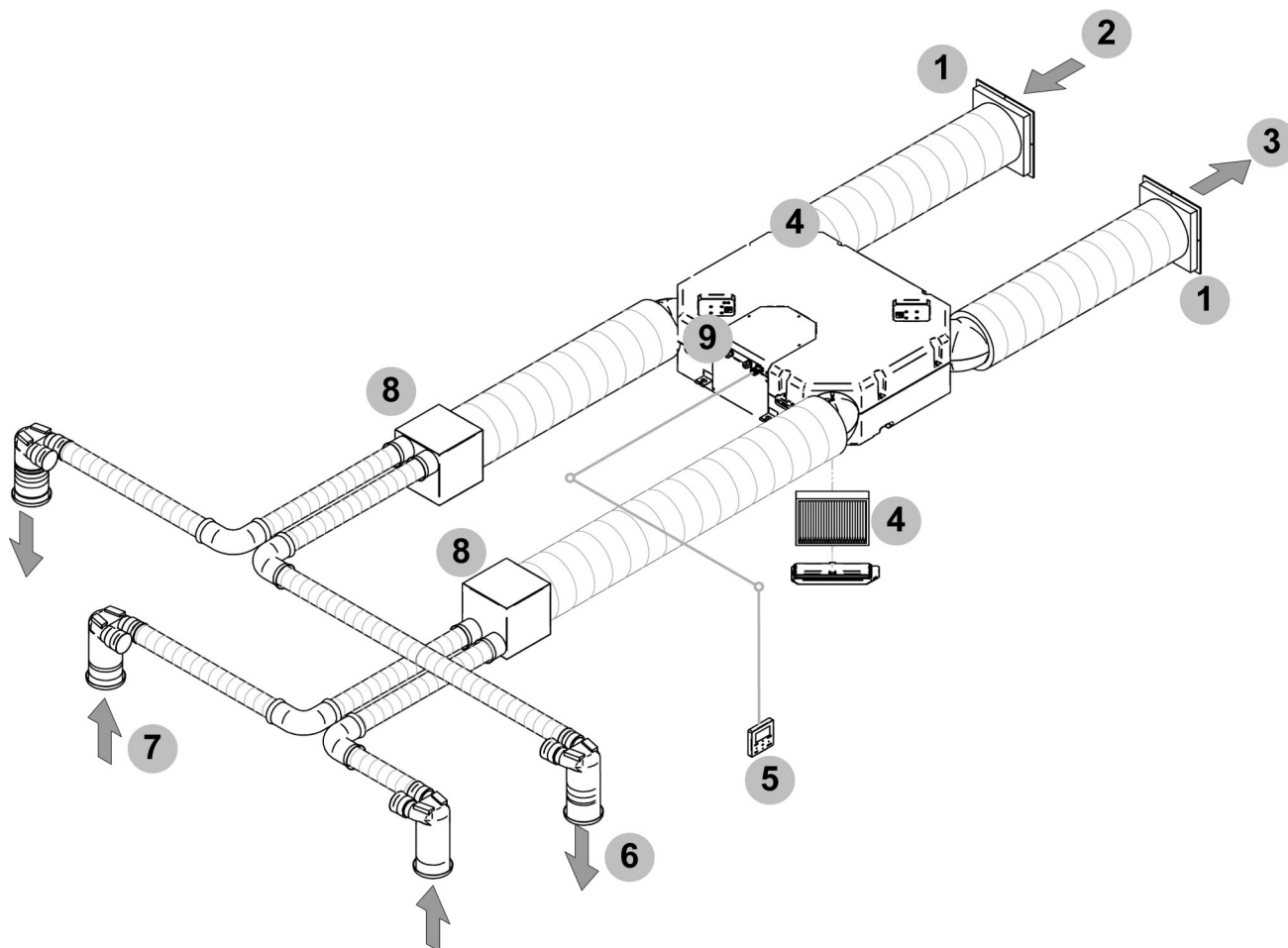

- | | |
|---|-----------------------------|
| 1 Grid to prevent small animals or leaves from entering inside (option) | 5 HMI keyboard |
| 2 Outdoor air intake | 6 Ambient air supply |
| 3 Ambient exhaust air | 7 Ambient air intake |
| 4 Air filter | 8 Distribution box (option) |
| | 9 Customer connections |

UNIT IDENTIFICATION

Serial number label

The serial number label is positioned on the unit, generally next to the electrical panel, and allows you to identify all the unit features.

The serial number label reports the regulations indications such as:

- Type of unit
- serial number (12 characters)
- year of manufacture
- wiring diagram number
- electrical data
- Type of refrigerant
- Charge of refrigerant
- manufacturer logo and address

The serial number label has not to be removed for any reason.

It contains fluorinated greenhouse gases

Type of refrigerant R32

Characteristics of R32 refrigerant:

- minimum environmental impact thanks to the low Global Warming Potential GWP
- low flammability, class A2L according to ISO 817
- low combustion speed
- low toxicity

The total amount of the charge of the unit is 0,3Kg.

The value is lower than the maximum critical value declared inside EN 603335-2-40 m1 (1,23Kg).

According this standard there are no limitations of the minimum space to be installed.

Physical characteristics of the R32 refrigerant		
Safety class (ISO 817)	A2L	
GWP	675	
LFL Low flammability limit	0.307	kg/m ³ @ 60°C
BV Burning velocity	6,7	cm/s
Boiling point	-52	°C
GWP	675	100 yr ITH
GWP	677	ARS 100 yr ITH
Self-ignition temperature	648	°C

The refrigerant quantity is indicated on the unit plate
Quantity factory-loaded refrigerant and equivalent CO₂ tons:

Size	Refrigerant (Kg)	Equivalent CO ₂ tons
Size 2	0,3	0,2

Serial number

It identifies uniquely each unit.

It identifies specific spare parts for the unit.

Intervention requests

Note data from the serial number label and write them in the table sideways, so you will find them easily when needed.

In case of intervention you have to provide the data

Serie
Size
Serial number
Year of manufacture
Wiring diagram

When ordering repair parts please always give the following information:

Model, serial and product number.

Parts name.

User training

The installer has to train the user on:

- start-up / shutdown
- set points change
- standby mode
- Maintenance
- what to do / what not to do in case of breakdown

Data updating

Continuous product improvements may imply manual data changes.

Visit manufacturer web site www.clivet.it for the data updating

PRELIMINARY INFORMATION

! Before beginning the work, ensure you that have the final project for installing the aeraulic, hydraulic, electric, drains and positioning the units.

Operate in compliance with safety regulations in force .



Use single protection devices.



Recommended instruments

Set of Philips and flathead screwdrivers;
 Cutters;
 Drill;
 Scissors;
 Set of open spanners or pipe wrenches;
 Range;
 Hydraulic material for the sealing of the threads;
 Electrical equipment for the connections;
 Cut prevention gloves;
 Tester and amperometric pliers.

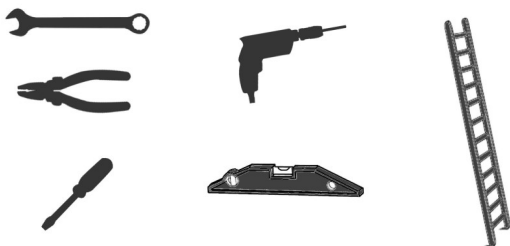

! BEFORE REQUESTING START-UP

- Completed system
- Completed aeraulic system and free of dirt
- Electric connections

DELIVERY CONTROL



- Do not trample

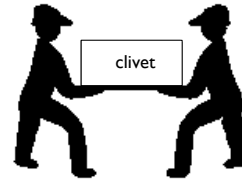

- Do not leave loose packages during the transport



Before accepting the delivery you have to check:

- that the unit hasn't been damaged during transport
- that the materials delivered correspond with that indicated on the transport document comparing the data with the identification label 'A' positioned on the packaging.

In case of damage or anomaly:

- write down on the transport document the damage you found and quote this sentence: "Conditional acceptance — clear evidence of deficiencies/ damages during transport".
- Contest by fax and registered mail with advice of receipt to supplier and the carrier.

Any disputes must be made within the 8 days owing the delivery. Complaints after this period are invalid.

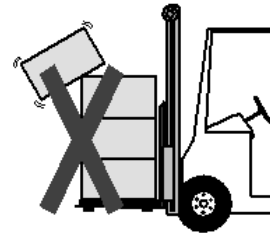

STORAGE

Shelter from: direct sunlight, rain, sand and wind.

Stocking temperature:

maximum 50°C

minimum -10°C

The respect of the instructions on the exterior side of the packaging assures the physical and functional integrity of the unit for the final user's advantage.

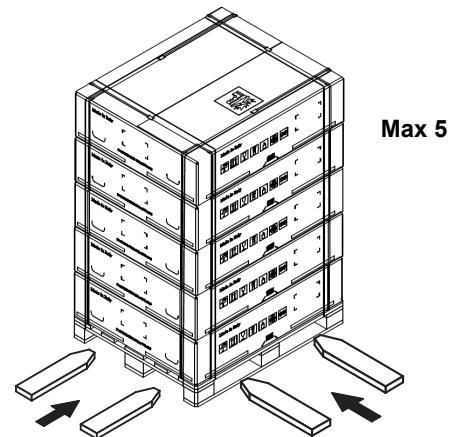

HANDLING

The following examples are indications; the choice of the means and of the handling modes will depend on factors, such as:

- The unit weight
- Type and overall dimensions of the unit
- Place and route for the handling (dirt yard, asphalted square, etc.)
- Condition of the place of destination (roof, square, etc.) distances, drops and gradients.

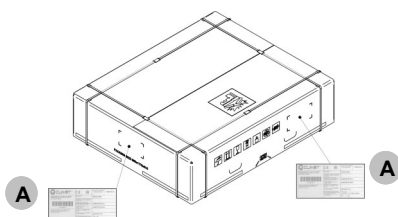

Lifting with forks:

- Insert the forks as indicated in the figure.
- It is forbidden to lift simultaneously more packages letting them loose.
- In case of lifting of more units at the same time, an appropriate container must be used.

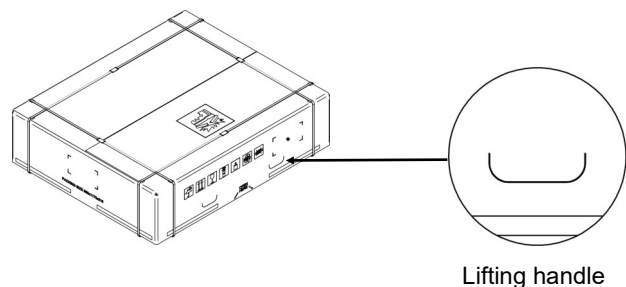

Lifting handle

Packing removing

Be careful not to damage the unit.

- Cut the fixing strips.
- Remove the packaging lifting it upwards.

Keep packing material out of children's reach it may be dangerous.
Recycle and dispose of packing material in conformity with local regulations.

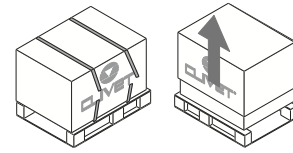

KIT REMOVAL

The unit is supplied in a single pack and is equipped with:

HMI keyboard

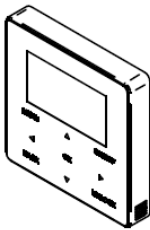

Anti-vibration

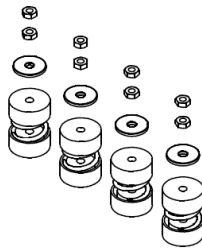

Torx insert for screwdriver

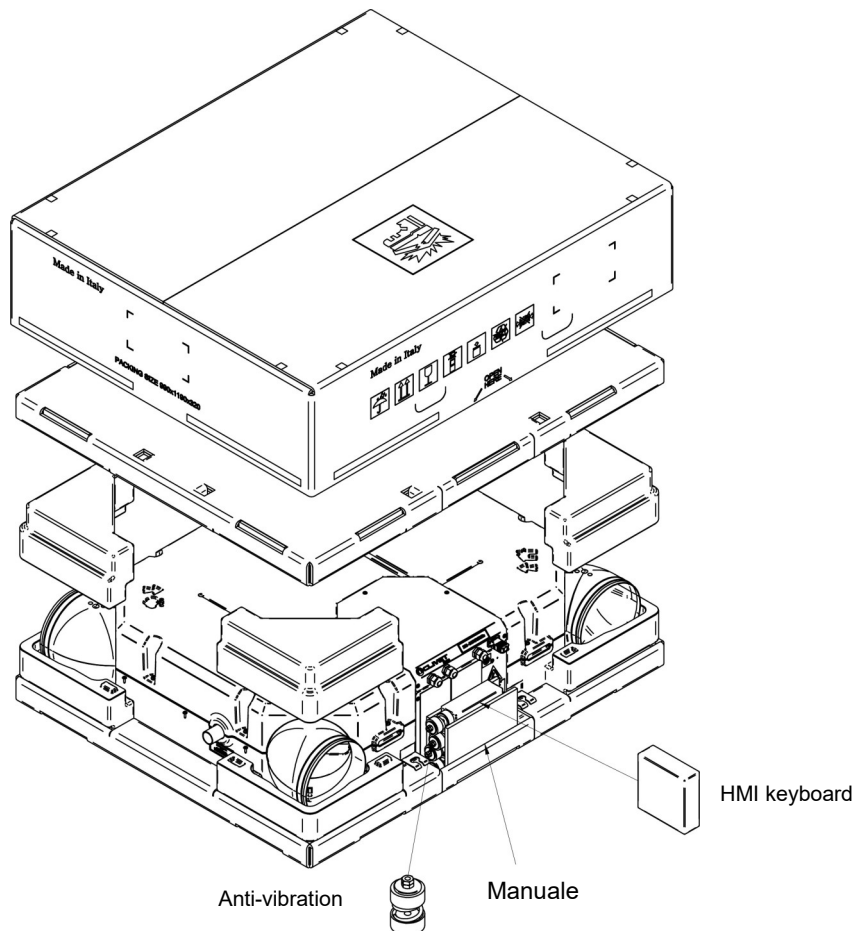

CLEARANCE ACCESS RECOMMENDED

! The installation has been implemented by qualified technical personnel only and that the instructions contained in the present manual and the local regulations in force have been adhered to.

Intended use

● Use the unit for the air treatment.
Follow the limits defined in the technical bulletin and on this manual.

Do not treat air with :
high concentrations of dust
aggressive substances
residues from industrial processing.

The unit has been designed to be installed :

- indoor
- in fixed position

● The unit can not be installed outdoor or in a room / compartment where the temperature can drop below 10°C.

Choose the installation place according to the following criteria:

- customer approval
- safe accessible position
- the operation noise and air flow expelled shall not affect neighbors
- spaces for conduits
- avoid flood-prone places;
- verify the unit weight and bearing point capacity;
- verify that all bearing points are aligned and levelled
- unit in bubble level
- plan in the false ceiling the openings indicated in the functional clearances to allow the access to the unit for the maintenance operations
- Ceiling positioning : let free the projection to the ground of the unit and of the functional clearances to allow the access with ladders or other means
- Floor positioning : install the unit raised from the ground, on a frame to permit the maintenance of the filter (bottom extraction).



Ceiling positioning and Floor, the unit for these two type of installation is selled with the protection fairing in sheet metal

Limit vibration transmission:

- use antivibration devices on unit bearing/supporting points
- install flexible joints on the hydraulic/aeraulic connections.



Neglecting these aspects may decrease the unit performances and life.

Consider sound emissions

Avoid installations next to bedrooms

If the unit is installed near bedrooms, it is recommended that acoustic insulation is arranged. **!**

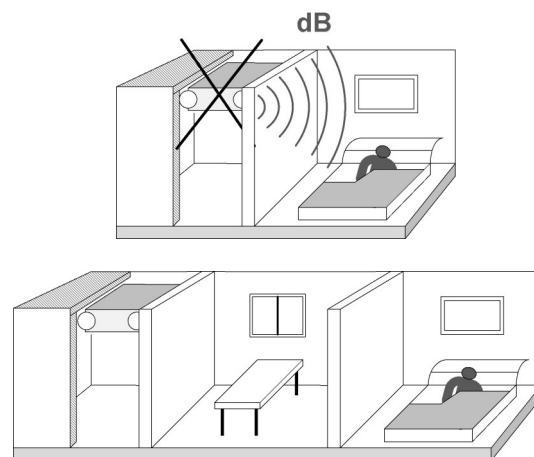

The functional clearances have to :

- guarantee the unit good operating
- allow the maintenance operations
- safeguard the authorized operators and the exposed person.
- position the unit taking into consideration the clearances indicated in the dimensional
- consider the space necessary for filter extraction .

UNIT IN BUBBLE LEVEL

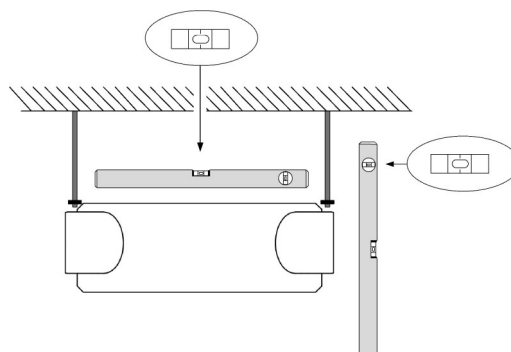

UNIT FIXING POINTS

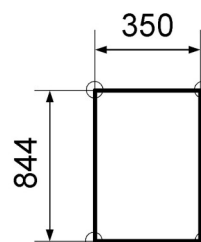

FLOOR INSTALLATION

- Insert the M8 threaded bar (not supplied) to on the support base.
- Screw the nuts, insert the flat washer.
- Insert the antibration
- Pass the M8 threaded rods into of the support bracket on the unit.
- Insert the flat washer
- Screw the nut
- Do not over tighten the nuts, the springs, because if too much crushed they don't absorb vibrations

For floor positioning or installation not in false ceiling the unit provided with sheet metal cover.

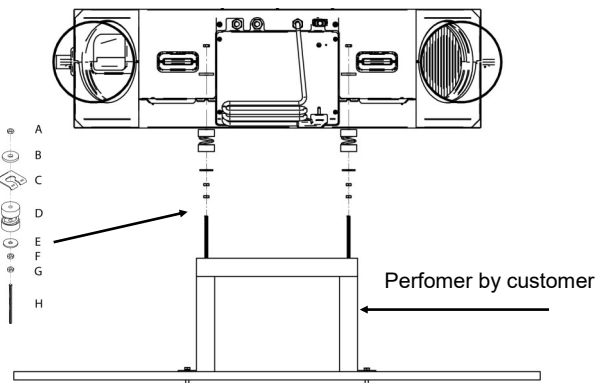
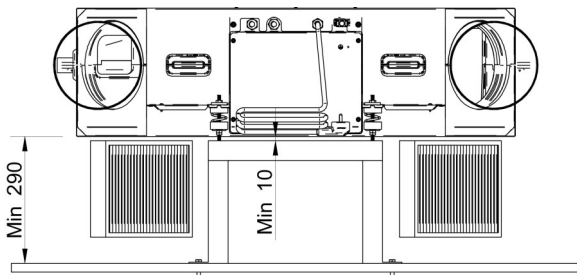

- | | | |
|----------------|-----------------------|-------------------|
| a) nut | d) antivibration foot | g) nut |
| b) flat washer | e) flat washer | h) A threaded bar |
| c) bracket | f) nut | |

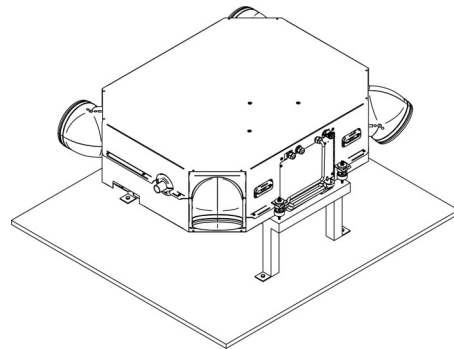
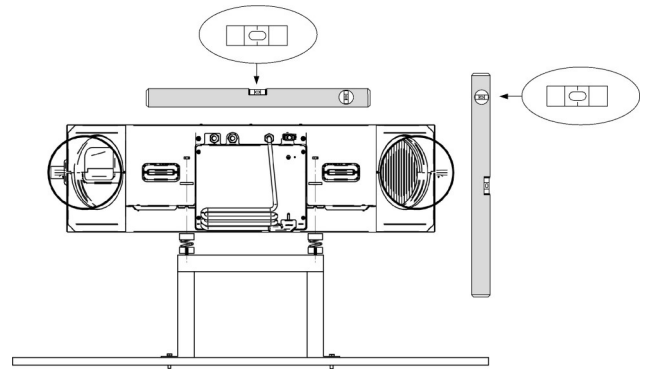
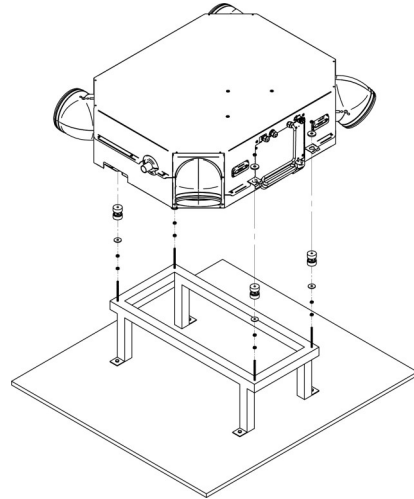

CEILING INSTALLATION

- Fix some M8 threaded bars (not supplied) to the ceiling.
- Pass the M8 threaded bars in the brackets on the unit.
- Insert on the threaded bar the antivibration .
- Insert the flat washer and tighten the nut to lock.
- Do not over tighten the nuts, the springs, because if too much crushed they don't absorb vibrations



For floor positioning or installation not in false ceiling the unit provided with sheet metal cover.

Closing housing

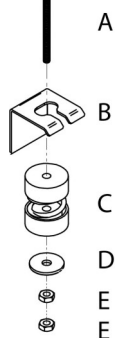
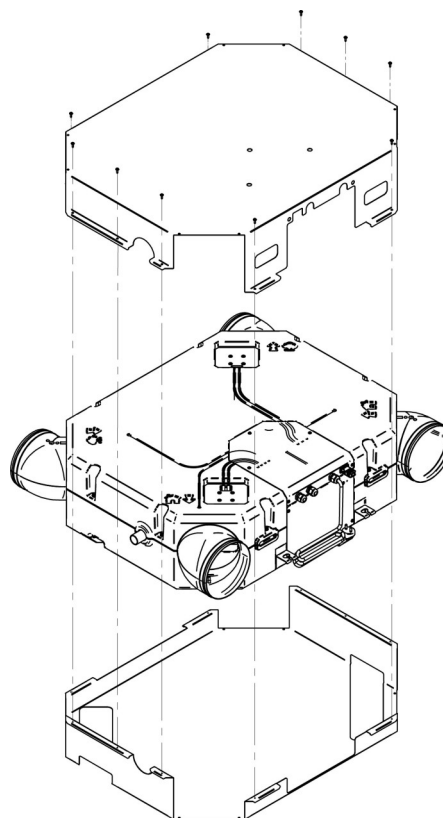
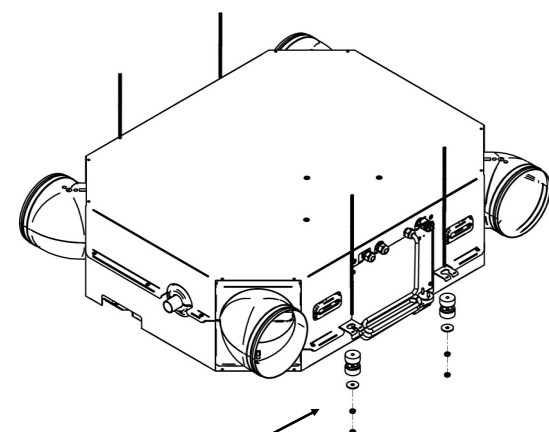

a) A threaded bar
b) Bracket

c) Antivibration foot
d) Flat washer

e) Nut

ELECTRIC PANEL

Access to the electrical panel
Sheet metal cover of the electrical panel fixed by
4 torx screws.

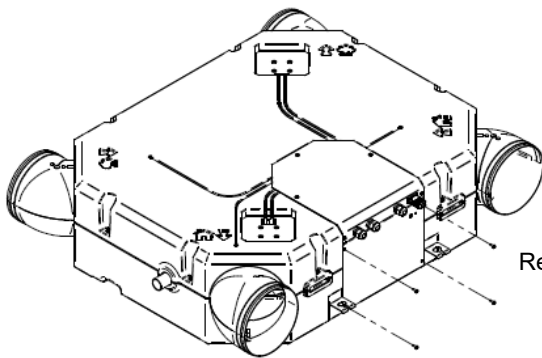
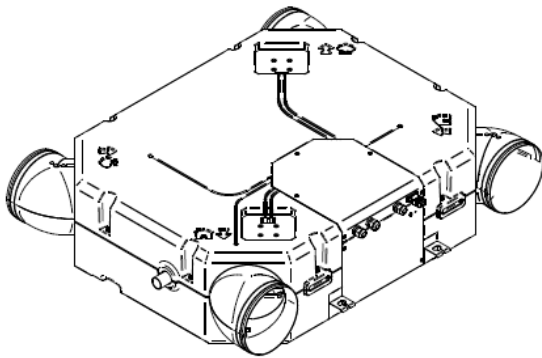

Remove the 4 torx screws.

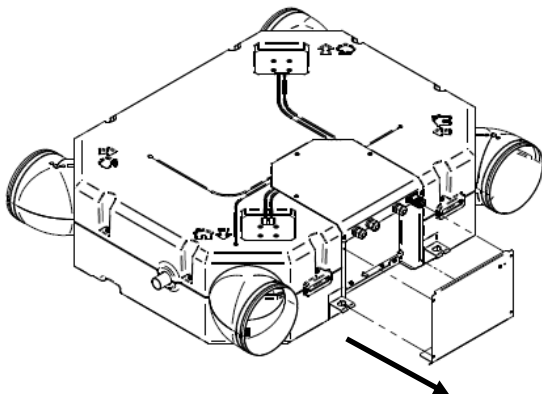

AMBIENT KEYBOARD

! The choice of the installation point is decisive for the environmental comfort and the energy consumption.

The thermostat must be placed :

- In a room with medium temperature and humidity conditions, representative of the other rooms
- at a height of **150 cm**
- preferably on an internal wall

Positions to avoid :

- next to heat sources
- points exposed to direct sunlight
- in a position with air rejected from outlets or diffusers
- behind curtains or pieces of furniture
- near windows and doors to the outside
- on walls crossed by fireplaces or heating ducts
- on external walls.

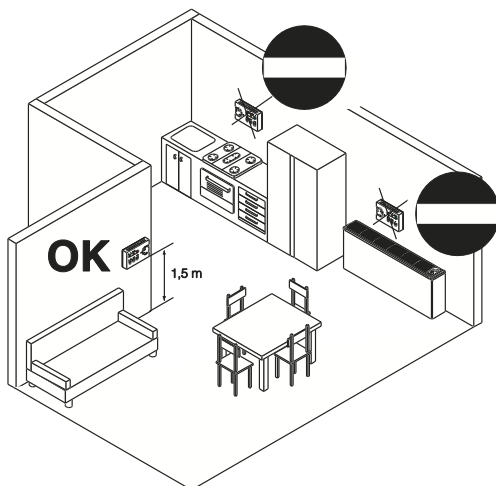
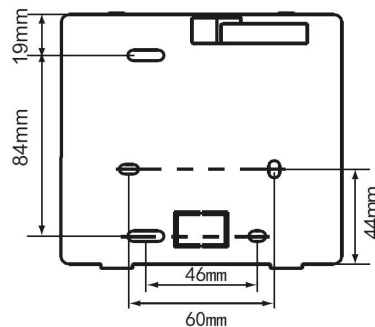
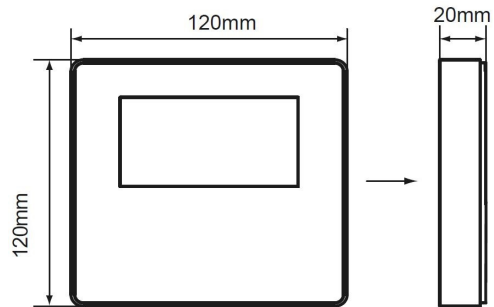

Use straight head screwdriver to insert into the buckling position in the bottom of keyboard, and spin the screwdriver to take down the back cover. (Pay attention to spinning direction, otherwise will damage the back cover!)

Use three GB950-86 M4X20 screws to directly install the back cover on the wall.

Use two M4X25 GB823-88screws to install the back cover on the 86 electrician box, and use one GB950-86 M4X20 screws for fixing on the wall.

Adjust the length of two plastic screw bars in the accessory to be standard length from the electrical box screw bar to the wall. Make sure when install the screw bar to the wall, make it as flat as the wall.

Use cross head screws to fix the keyboard bottom cover in the wall through the screw bar. Make sure the keyboard bottom cover is on the same level after installation, and then install the keyboard back to the bottom cover.

Over fasten the screw will lead to deformation of back cover.

3 - POSITIONING

Screw hole installed on the wall, use three GB950-86 M4X20

Screw hole fixed on the wall, use one GB950-86 M4X20

A - Screw hole installed on 86 Electrician box, use two M4X25 GB823-88

Cutting place of left down side wire outlet

Left down side wire outlet

44mm
60mm
Wiring hole

Wall hole and wiring hole
Diameter 8--10

After adjusting the front cover and then buckle the front cover; avoid clamping the communication switching wire during installation.

Sensor can not be affected with damp.

B - Trap
C - Putty

✓ X X X

CONDENSATE DISCHARGE

! The condensate must be disposed in order to avoid damages to people and things.

- Unit discharge fitting: the connection must not transmit mechanical stresses and must be performed taking care not to damage the unit discharge fitting.
- It is mandatory to install siphon that, eliminating the negative pressure caused by the fan, prevents the air intake from the discharge duct.
- The ducting must have a min. slope of 5% to allow the runoff.
- Anchor the ducting with an adequate number of supports. Otherwise are generated duct failures and air locks that prevent the runoff.
- Insulate the duct and the siphon to avoid the condensate drippings.
- Connect the condensate discharge to a sewerage drainage network. DO NOT use white water or drainage networks to avoid the aspiration of odours in the case of evaporation of water contained in the siphon.
- The connection must not be hermetic, so as to allow the venting and avoid possible liquid returns.
- Check at the end of the work, the regular condensate runoff pouring some water in the tray.



Standard condensate drain pump (degree of protection IPX4)

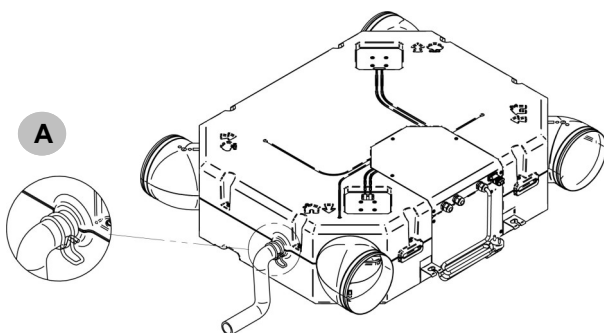

A - Condensate discharge fitting \varnothing 32
Tube and clamp provided by the customer

Siphon

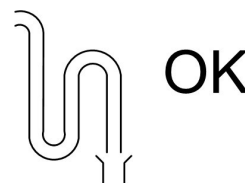
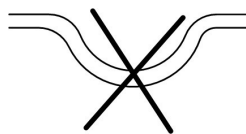

Siphon height calculation

$$T = 2P$$

$$S = T/2$$

P is the pressure determined by the fan in correspondence of the condensate collection bowl (approx. 1 mm = 9.81 Pa)

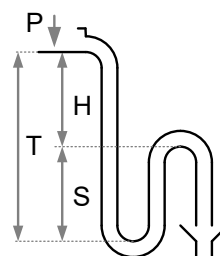

Example:

$$P = 100 \text{ Pa} = 10 \text{ mm}$$

$$T = 2P = 20 \text{ mm}$$

$$S = T/2 = 10 \text{ mm}$$

RISK OF FREEZE

Prevent the risk of freeze if the unit and drain can be subject to temperatures close to 0°C.

For example:

- safeguard the pipes with heating cables placed under the insulation .
- insulate the pipes.
- perform the installation draining if unused for long periods.

AERAILIC DESIGN CRITERIA

- !** Make sure you have the final plan of the ELFOAir aerailic system.
- !** The dimensioning and the correct execution of the aerailic connections are critical to ensure the unit operating and an appropriate level of quietness in the served area.

Here are some indications, as a simple checklist to support the installer and the designer of the installation.

- AIR RENEWALS = 0,5 volumes per hour , max 1 volume per hour ; in the volume are not considered the extraction rooms (kitchens, bathrooms, etc.)
- AIR SPEED included between 2 and 3 m/sec (it guarantees the system silence)
- RETURN AIR in the kitchens / bathrooms / rooms with vapours, unpleasant odours
- SUPPLY AIR in the living room , bedrooms , studies etc....

SIZE CONNECTIONS

* Ensure sufficient space for the conduit accessories

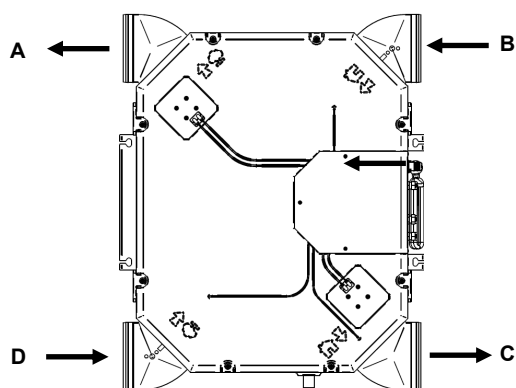
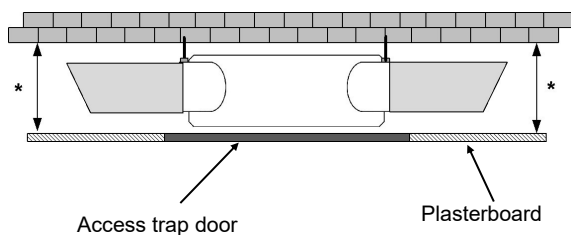

A	Air exhaust	Ø 200 mm
B	Ambient air return	Ø 200 mm
C	Ambient air distribution	Ø 200 mm
D	Fresh air intake	Ø 200 mm

CONNECTION ROTATION

The 4 connections can rotate 360 °

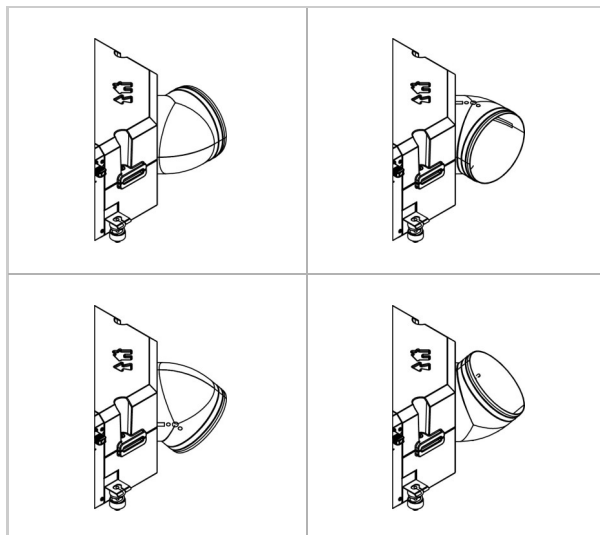

AIR DISTRIBUTION / EXHAUST SYSTEM

If the duct outlets for the outdoor air inlet and exhaust are outside of coverage, must end with a 90 ° bend downward, to prevent entry of water from the air inlet, if they are outside the roof, they must end with roof hoods (not provided by Clivet), so as to prevent water from entering. During the design stage, their features must limit load losses so as not to affect the correct operation of the unit.

To perform the ductings:

- Connect the ductings fixing them to the connections with the special hookings to the circular flanges.
- The duct weight should not lie on the connection flanges.
- Put antivibration joints between ducts and units.
- The connection to the flanges and among the different duct sections must guarantee the air seal, avoiding air dispersions in supply and return that penalize the overall efficiency of the installation.
- Limit the pressure drops by optimizing the path, the type and the number of curves and branches.
- Use curves of large radius.
- Thermally insulate the supply ducts to avoid heat losses and condensate.

Do not cover the nozzles/grilles with objects (furniture, wardrobes, etc.), which would prevent the regular circulation of air in the room.



Avoid recirculation of exhaust/return air

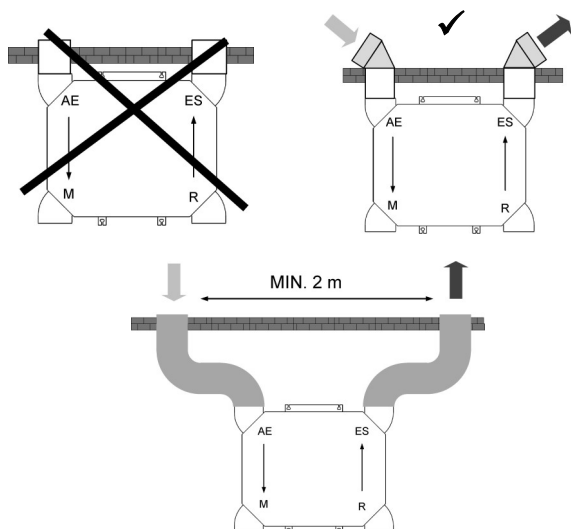

Exhaust/return grille (GR200X)

Accessory separately supplied

Install on:

1. Fresh air intake
to be placed in an area with a low concentration of impurities (dust, odours, exhaust fumes, etc.).
2. Ambient air exhaust
away from terraces, balconies, property boundary lines; avoid windward zones.

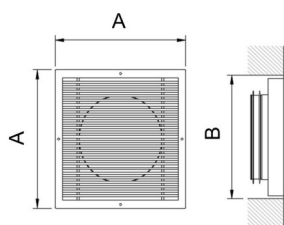
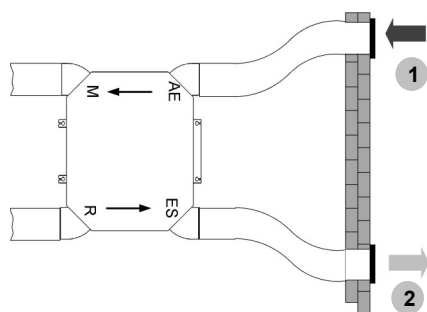

	A	B
Size 2	310	276

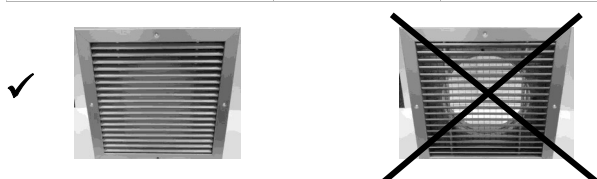

Rooftop exhaust/return

Unit installed in the attic with ejection/intake on the roof. Install pipes and roof hoods (not provided by Clivet).

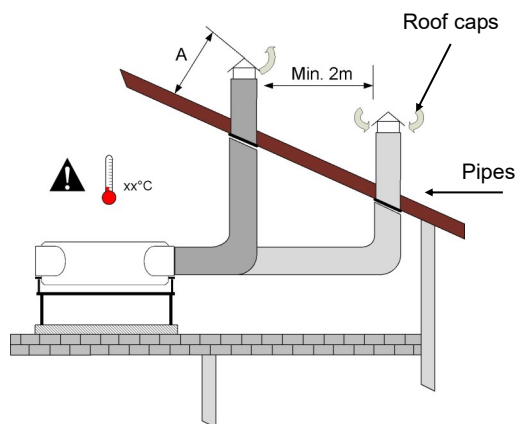

A ≥ 500 mm In areas with abundant snowfalls

Insulated flexible pipe

- A. Thermally insulate the supply ducts to avoid heat losses and condensate.

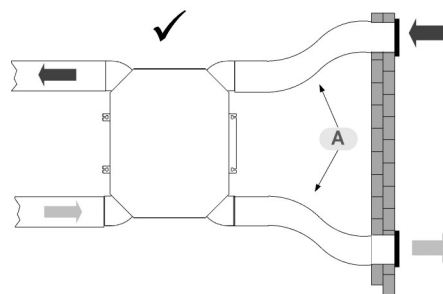

- B. Avoid compressing the pipes and tight bends to prevent any pressure drop.
- The flexible pipe supplied by Clivet allows bends of 180° to be made without any compression and without any reduction in pressure drop

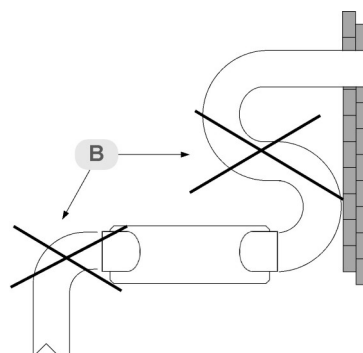

! The ducts should not be tilted towards unit to avoid the condensate and water return.

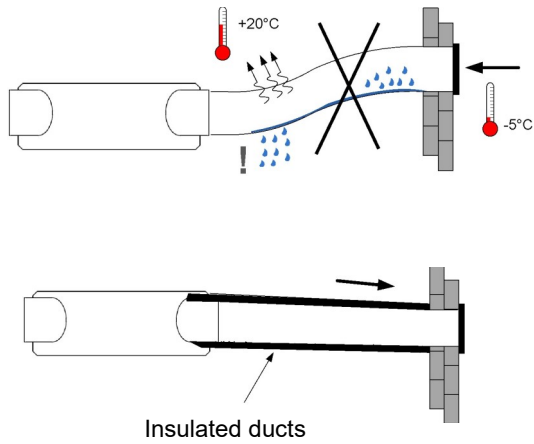

A - Flexible pipe fixing

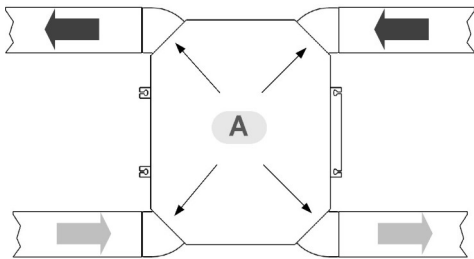

Isolation of the adjustable connections

Apply on the 4 connections the lining anti-condensation.

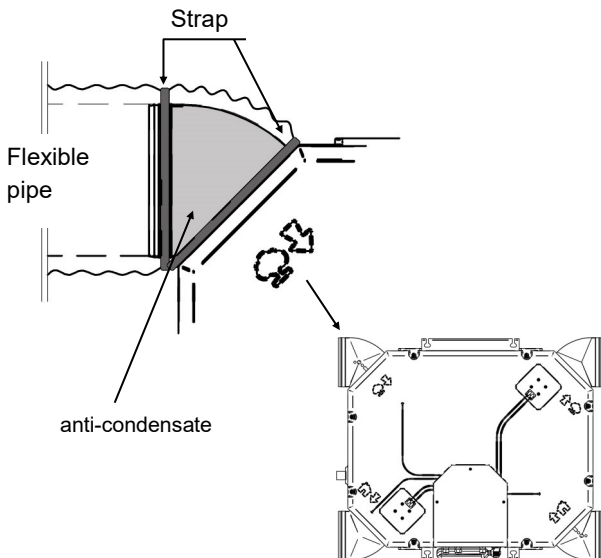

Layers of the flexible pipe

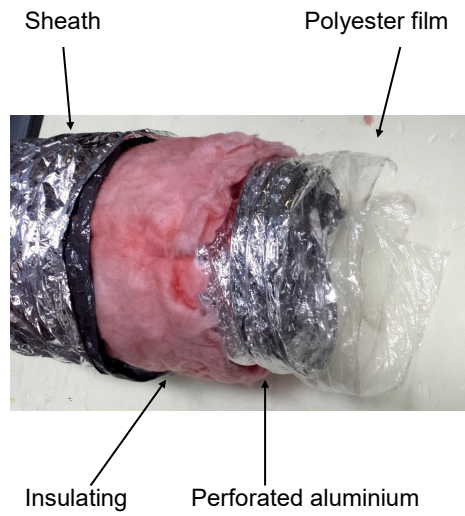

1 - Introduce the perforated aluminium part



2 - Pull the polyester part down (plastic)

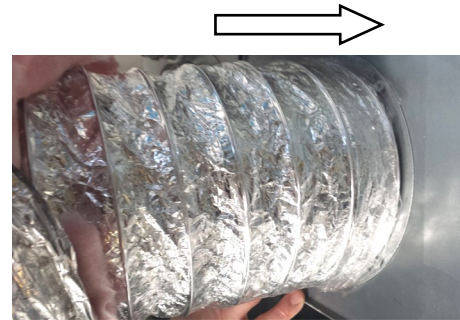

3 - Tighten well using the strap



4 - Pull the insulating layer down

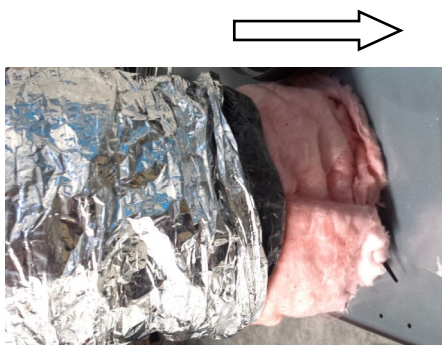

5 - Pull the sheath down

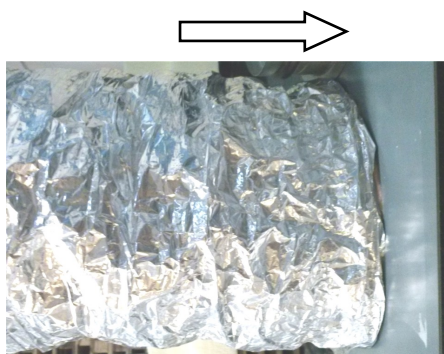

6 - Tighten well using the strap



Air distribution box (can be inspected)

If there is enough space between the ceiling and the box, the acoustic insulation can be further improved by further covering the air distribution box. Use soundproof material (low-density polyester fibre is recommended).

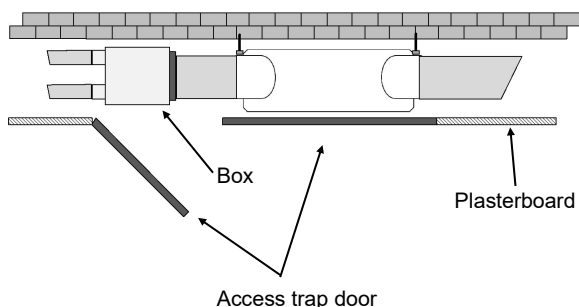

AIRJET supply diffuser + extraction valve

The extraction valve must not be positioned on the side facing the air supply.

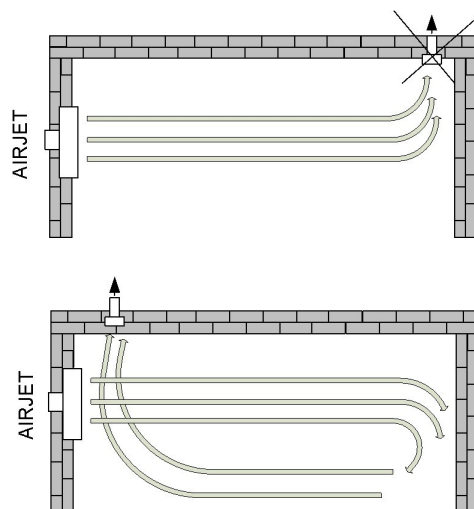

Air distribution valve (VIEX)

The air distribution valve must not be positioned above the bed, for example.

Adjust the valve so that the air supply does not exceed 30m³/h.

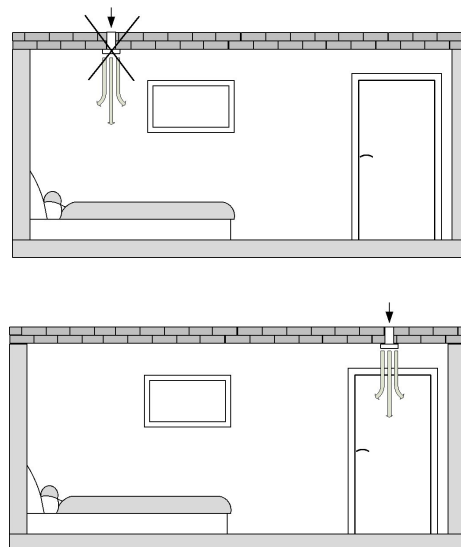

Warning

During the installation, carefully close all the open points of the aeraulic system as well as the intake/ supply grilles in order to prevent dust and debris from the construction site from entering the pipes.

This way you can prevent the unit from clogging when it is started for the first time and also avoid any additional costs for the cleaning of the aeraulic system and the unit.

AERAULIC SYSTEM

 Before installing the aeraulic system, check the passages of the pipes and position of the accessories based on the design.

- Unit position:
 - in a specific room (where the temperature never drops below 10°C and the ambient return air temperature never drops below 15°C), away from bedrooms. Check useful height available in relation to the unit's height and local regulatory constraints.
- Choose the position of the fresh air intake:
 - check local regulations (especially the minimum height between the lower point of the intake and the ground)
 - avoid positions excessively close to the ground (entry of odours / radon)
 - choose the shortest possible distance from the unit
 - install anti-intrusion grilles to prevent small animals or leaves from entering (accessory supplied separately)
 - prevent water infiltrations
 - avoid positions close to windows, terraces, etc.
 - avoid positions close to flues of boilers, extractors, etc.
 - avoid vehicle parking areas
 - avoid bypasses with stale air exhaust
- Choose the position of the exhaust outlet:
 - see previous point
 - avoid positions close to windows, terraces, etc.
 - avoid windward zones
 - avoid pedestrian passages
 - avoid unventilated attics, garages, basements
- Supply and return box:
 - to be installed in a barycentric position, so the air ducts have a similar height
- Choose the rooms with air intake: living room, bedrooms, study, etc.....
- Identify the position of the intake nozzles (ceiling, wall, or floor)
- Choose the rooms with air extraction:
 - kitchen, bathroom, store rooms, lofts, dry cleaners, walk-in closet, etc.
 - avoid suction from the kitchen hood, as it is too close to the hob. Minimum horizontal distance from the hob ~ 1 m
- Choose the outlets:
 - always high, as this position facilitates moisture extraction
- Check the passage of air between the various rooms (a gap below the door of 1 cm approx.) to allow air circulation



ELECTRICAL CONNECTION DIAGRAM

! All electrical operations should be performed by trained personnel having the necessary requirements by the regulations in force and being informed about the risks relevant to these activities.

The unit must be installed with an Creepage Breaker near the power supply and must be effectively earthed.

A creepage breaker must be installed adjacent to the power supply

! Set the electric leakage protector according to the relevant electric technical standards of the State.

! After wire connection, check it again and make sure the correctness before power on.

! Do not use water pipes to earthing connection of the unit

WARNING

This unit is required reliable earthing before usage, otherwise might cause death or injury.



PRINCIPAL ELECTRICAL PANEL

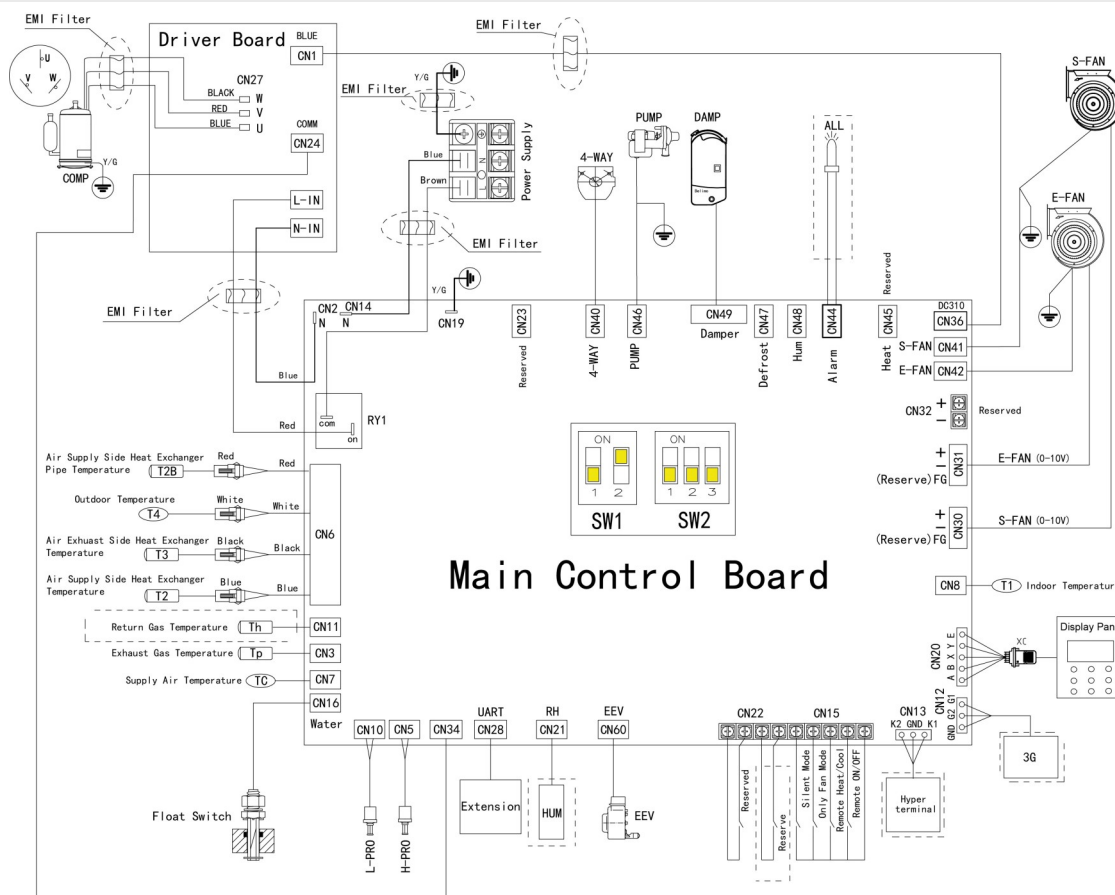

L-PRO	Low Pressure Switch Protection	DAMP	Damper
H-PRO	High Pressure Switch Protection	4-WAY	Four Way Valve
Extension	Expansion Board	S-FAN	Supply Fan
3G	3G Module	E-FAN	Exhaust Fan
ALL	Cumulative Alarm	COMP	Compressor
HUM	Humidity sensor	EEV	Electronic Expansion Valve
PUMP	Condensate Drain Pump	SW1 / SW2	DIP Switch

ELECTRICAL CONNECTION DIAGRAM

- A - Keyboard HMI
Cable 5x0,75 mm² shielded
- B - 220/240 ~50HZ power supply
Provide the power outlet (on/off switch + schuko)
- C - Electrical panel
Auxiliary connection (Clivet Eye, remote On/Off)

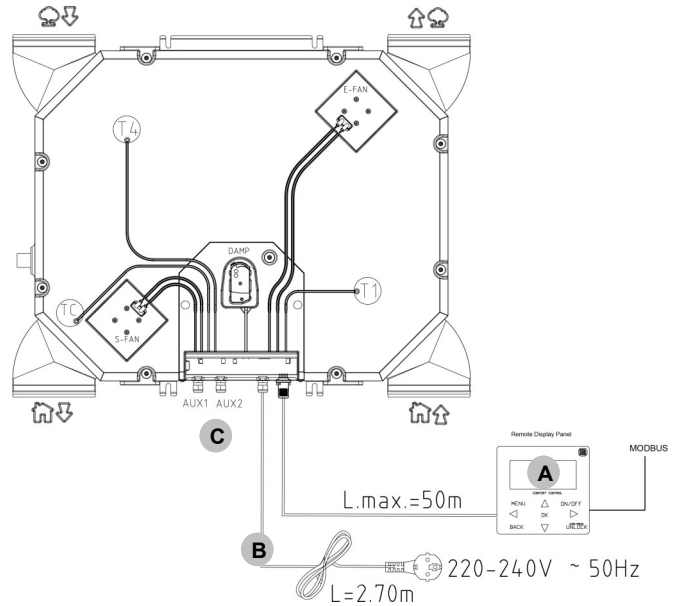

REMOTE CONTROLS

Refer to the unit electrical diagram (the number of the diagram is shown on the serial number label).

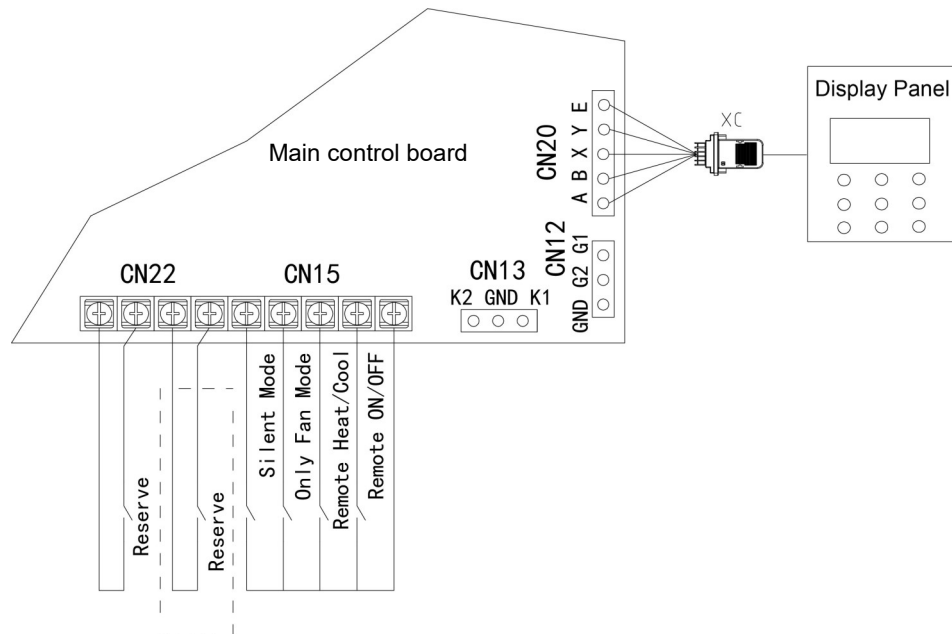

Remote summer-winter selector switch (heat/cool)

It allows the change of the operating mode from heating to cooling from an external control.

On - Off

Switch on / off from a remote control

Silent

It reduces the fan speed, and limit s the compressor

frequency. It is possible to setting 2 types of silence: normal silent, ultra silent

Ventilation (fan)

Only the fans are actives and no check on the temperature and humidity is performed the compressor is disabled

PRELIMINARY INFORMATION

General

- The indicated operations should be done by qualified technician with specific training on the product.
- The service centres shall perform by request the start-up; the electrical, hydraulic connections and the remaining work on the system are provided by the installer.
- Agree upon the start-up date with the service centre sufficiently in advance .

Before checking, please verify that :

- the unit should be installed properly and in conformity with this manual.
- the electrical power supply line should be sectioned at the beginning.
- the line sectioning device is open, locked and equipped with the suitable warning signs.
- ensure no voltage is present .

 After turning off the power, wait at least 5 minutes before accessing to the electrical panel or any other electrical component.

 Before accessing check with a multimeter that there are no residual stresses.

Refrigerant circuit

 • **Use the pressure taps only if you need to load or unload the refrigerant circuit.**

Aeraulic system

Verify that:

- the rooms are clean (free from dirt)
- possible dampers are opened and calibrated
- the air filters are not removed from unit and are cleaned (possible ventilation checks and the operating starting period determinate a ducting “cleaning” with consequent filter precocious clogging, filters that must be cleaned and replaced)
- ducting are completed, connected and without obstructions
- Grilles, outlets, and diffusers must be free of obstructions (furniture, shelves, etc.), open and pre-calibrated, so as to ensure proper air distribution, which is essential to comfort in the room

Electrical circuit

- Verify that the unit is connected to the ground plant .
- Check tightening of the conductors: the vibrations caused by handling and transport might cause losing .
- Feed the unit by closing the sectioning device, but leave it on OFF

- Check the voltage and frequency net values which must be within the limits:

220/240 ~50HZ +/- 6%

Check that the phases unbalancing must be lower than 2%

The operating out of the limits can cause irreversible damages and makes decay the warranty. 

Voltages

Check that the air and water temperatures are within the operating limits.

With unit at steady state, i.e. in stable and close-to-work conditions, check:

- supply voltage
- unit total absorption
- absorption of each electric load.

Remote controls / consents

Check that the used remote controls are wired and enabled with the respective parameters : 

- ON-OFF
- Summer-Winter
- Silent
- Ventilation

STARTING REPORT

Identifying the operating objective conditions is useful to control the unit over time.

With unit at steady state, i.e. in stable and close-to-work conditions, identify the following data :

- Total voltages and absorptions with unit at full load
- Absorptions of the different electric loads (compressors, fans, pumps etc)
- Temperatures and air flow of the different fluids (water, air) both in input and in output from the unit
- The measurements must be kept and made available during maintenance interventions.

2014/68/UE PED DIRECTIVE

DIRECTIVE 2014/68/UE PED gives instructions for installers, users and maintenance technicians as well. Refer to local regulations; briefly and as an example, see the following:

Compulsory verification of the first installation:

- only for units assembled on the installer’s building site (for ex. Condensing circuit + direct expansion unit)

Certification of setting in service:

- for all the units

Periodical verifications:

- to be executed with the frequency indicated by the Manufacturer (see the “maintenance inspections” paragraph)

PRELIMINARY CHECKS

The indicated operations should be done by qualified technician with specific training on the product.

Upon request, the service centres performing the start-up.

The electrical, water connections and the other system works are by the installer.

Agree upon in advance the star-up data with the service centre.

Before checking, please verify the following:

- the unit should be installed properly and in conformity with this manual
- the electrical power supply line should be isolated at the beginning
- the unit isolator is open, locked and equipped with the suitable warning
- make sure no tension is present

 After turning off the power, wait at least 5 minutes before accessing to the electrical panel or any other electrical component.
Before accessing check with a multimeter that there are no residual stresses.

 **Before starting the unit, make sure that the room is free of dust and debris and that the conduits are not blocked**

The following check list is a brief reminder of the points to check and of the operations to perform to start-up the unit.

For details refer to the various chapters in the manual.

√ **Preliminary checks
verify the presence/efficiency of:**

- 1 Safe access
- 2 Are the functional spaces being observed
- 3 Structure integrity
- 4 Unit in bubble level
- 5 Unit on vibration isolators
- 6 Presence of anti-intrusion grille against small animals or leaves (option)
- 7 Air flow: correct return and supply (no bypass)
- 8 Completed aeraulic system
- 9 Insulation of supply conduits to room and air exhaust conduits
- 10 Presence of anti-vibration joints between the conduit and unit (e.g. canvas conduits)
- 11 Condensate drain with trap - sloping
- 12 Visual check of oil / leak presence
- 13 Electrical connections provided by the customer
- 14 Earthing connection
- 15 Proper overload fuse or circuit breaker protection installed.
- 16 Power supply cables separated by signal cables

START-UP SEQUENCE

During the initial start-up procedure, the airflow is setting (from HMI) to check the balance amount of air entering and exiting the environment.

Door and windows must be mounted.

External doors and windows must be closed.

Instruments needed in addition to normal instruments.

- Anemometer complete with probe to measure the differential pressure and vane probe.
- Aeraulic system plan compete with flow rates into the individual rooms.
- Rectangular and circular extensions to rest on the inlets in rooms in order to ensure an even air flow rate of the supply nozzles and extraction valves when this is measured.



✓ Start-up sequence

- Powered unit
- Unit ON
- Check for unusual vibrations or noise with the compressor and fans activated
- Verify that the inlets/outlets in the room and any dampers in the conduits are open
- Check the airflow (anemometer) by taking a reading directly on the external inlets and outlets (see table on page 33)
- If impossible to access the external inlets/outlets than check the airflows in the room using the following formula: **Airflow m³/h = Area (m²) x Speed (m/s) x 3600 seconds**
- Fans operation check
- With the compressor on, verify that the unit's power supply voltage falls between 207-253 V
- No anomalous vibrations check
- Instruct the customer on how to switch the device on/off, change the set-point and clean the filter
- Collect all the machine documentation and give it to the customer together with the commissioning report duly completed and signed.

Adjustable vents

VIEX - Extraction/intake valve

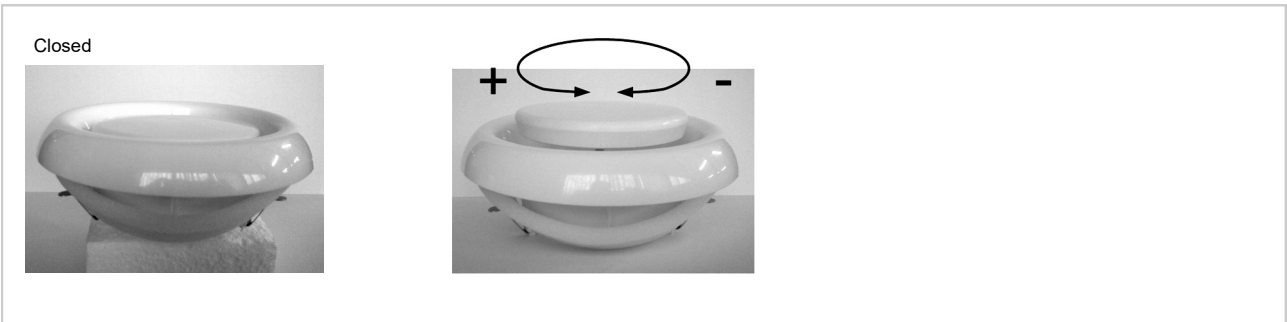

GQIEX - Extraction/intake squared grid

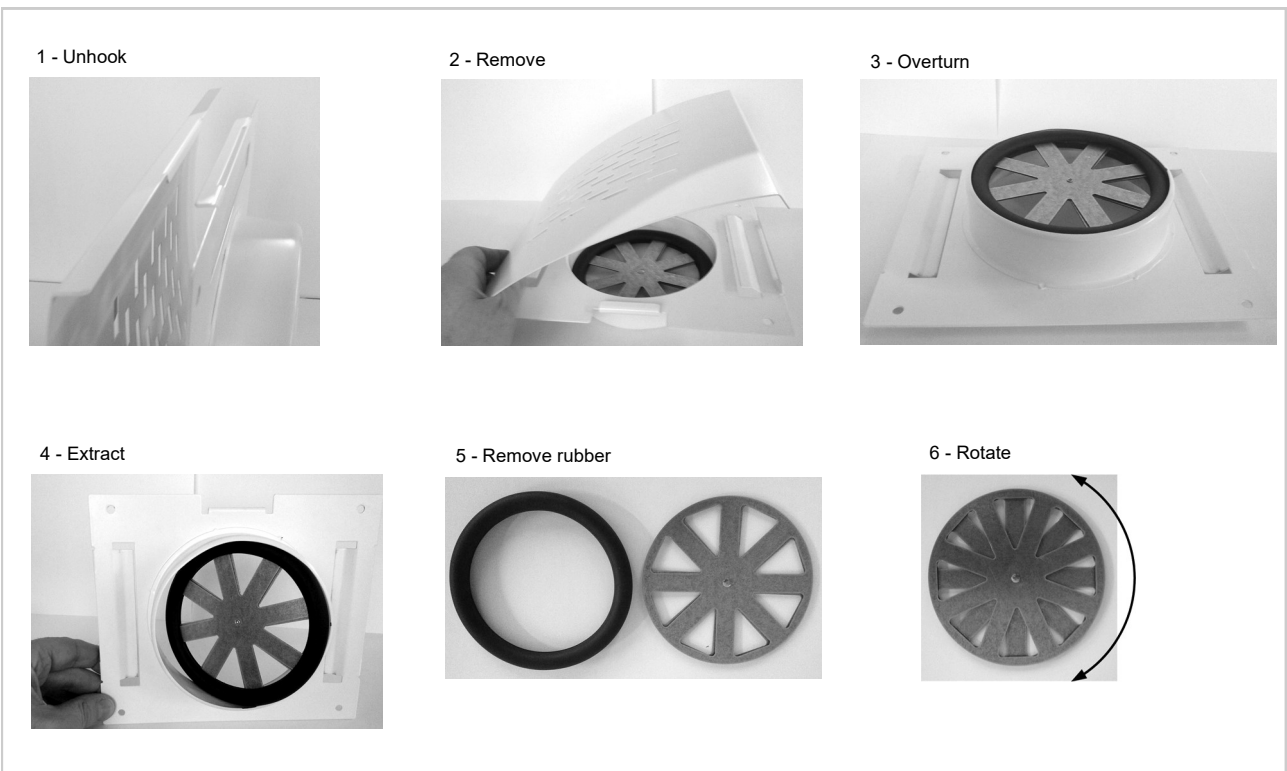

PAIR50X/80X - Suction/supply plenum with control damper

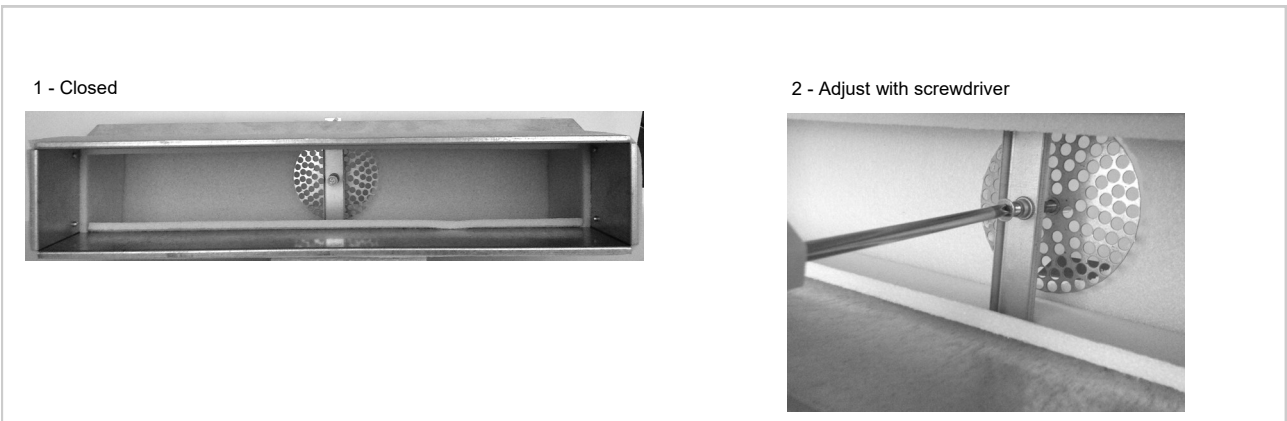

AIRFLOW TABLES

Airflows measured on the external inlets/outlets.

Example of conduits:

Minimum flow

circular tube Ø mm	airflow m ³ /h	speed medium m/s
160	125	1,73
200	125	1,11
250	125	0,71

square tube (L x H)		airflow m ³ /h	speed medium m/s
140	140	125	1,77
180	180	125	1,07
220	220	125	0,72

rectangular tube (LxH)		airflow m ³ /h	speed medium m/s
250	80	125	1,74
300	100	125	1,16
400	120	125	0,72

Maximum flow

circular tube Ø mm	airflow m ³ /h	speed medium m/s
160	320	4,42
200	320	2,83
250	320	1,81

square tube (L x H)		airflow m ³ /h	speed medium m/s
140	140	320	4,54
180	180	320	2,74
220	220	320	1,84

rectangular tube (LxH)		airflow m ³ /h	speed medium m/s
250	80	320	4,44
300	100	320	2,96
400	120	320	1,85

Nominal air flow rate

circular tube Ø mm	airflow m ³ /h	speed medium m/s
160	270	3,73
200	270	2,39
250	270	1,53

square tube (L x H)		airflow m ³ /h	speed medium m/s
140	140	270	2,83
180	180	270	1,71
220	220	270	1,15



rectangular tube (LxH)		airflow m ³ /h	speed medium m/s
250	80	270	3,75
300	100	270	2,50
400	120	270	1,56





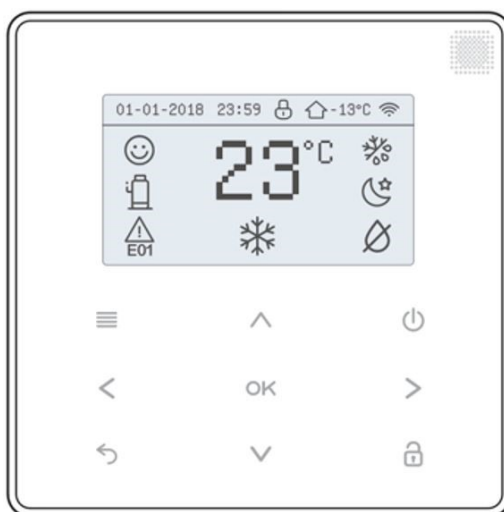









Setting values from keyboard (par. 1.12)

Speed setting	Airflow m ³ /h
W3	125
W4	150
W5	210
W6	270
W7	320

See menu : Operation parameter



 MENU	To access the various menus of the HOME page.
▲ UP ▼ DOWN ◀ LEFT ▶ RIGHT	To shift the cursor, modify the selection or modify the set value. The parameter can be rapidly modified by pressing it extendedly..
OK	To confirm an operation
 ON/OFF	To set the ON / OFF function
 BACK	To return to the previous level. Press to exit the current page and return to the previous page. Press extendedly to return to the home page directly.
UNLOCK	To lock/unlock.

   	<p>MODE:</p> <p>heating</p> <p>cooling</p> <p>auto</p> <p>ventilation</p>
	OFF: unit off
	WI-FI : indicates the connection with the mobile phone
24°C	Ambient temperature, detected by probe T1. When adjusting the temperature, indicates the setpoint.
	COMPRESSOR: indicator on when the compressor is running.
	DEFROSTING: indicator on when the unit is defrosting
	HUMIDITY CONTROL: indicator on when the unit is in cooling and the compressor is running.
	TIMER: indicator on when a valid timer has been set (weekly schedule).
	ALARM: indicator on when a fault occurs or a protection device intervenes.
E01	Indicates information specific to a fault or protection in progress.
	LOCK: indicator on when the controller's keypad is locked.
	SILENT: indicator on with unit in silent mode
	COMFORT: indicator on when the unit is in cooling / heating / auto mode and the compressor is running.
	Outdoor temperature

<p>Lock/unlock</p> <p>To lock/unlock the screen, press UNLOCK for 3 sec.</p> <p>With the keypad locked, if you press any key, the LOCK key flashes.</p>																	
<p>ON / OFF</p> <p>To turn on / off press ON / OFF.</p> <p>If a timer is active the unit cannot be switched off.</p> <p>The password is required to disable the timer.</p>	 																
<p>Adjustment Temperature</p> <p>Press LEFT - RIGHT to select</p> <p>Press UP - DOWN to change</p> <p>If no operations are made for more than 3 sec, the system automatically memorises the settings.</p> <p>Temperature setting range:</p> <table border="1" data-bbox="153 1254 1077 1509"> <thead> <tr> <th></th> <th>MIN °C</th> <th>MAX °C</th> <th>actory setting °C</th> </tr> </thead> <tbody> <tr> <td>Cooling</td> <td>22</td> <td>28</td> <td>24</td> </tr> <tr> <td>Heating</td> <td>17</td> <td>24</td> <td>20</td> </tr> <tr> <td>Auto</td> <td>17</td> <td>28</td> <td>22</td> </tr> </tbody> </table>		MIN °C	MAX °C	actory setting °C	Cooling	22	28	24	Heating	17	24	20	Auto	17	28	22	
	MIN °C	MAX °C	actory setting °C														
Cooling	22	28	24														
Heating	17	24	20														
Auto	17	28	22														
<p>Temperature cannot be adjusted:</p> <ul style="list-style-type: none"> • with AUTO TEMPERATURE SETTING function enabled • with TIMER active 																	

Menu

Press MENU

Press UP - DOWN to select each menu option.

Press OK to access the corresponding sub-menu

Press BACK to return to the home page .

Press MENU to return to the previous page .

MENU
OPERATION MODE
TIMER SETTING
MAIN PARAMETER
INTERFACE SETTING
SERVICE INFORMATION
OK ENTER 1/2 ↕

MENU
ASSISTANCE SETTING
OK ENTER 1/2 ↕

Operating mode

Choose the mode with UP end DOWN.

Confirm with OK.

After 10 sec, without any operation, the mode is memorised automatically

Function enabled only if parameter ENMode = 1.

Factory values for each mode:

Heating	Riscaldamento	20°C
Cooling	Raffreddamento	24°C
Auto	Automatico	22°C
Fan	Ventilazione	-

MENU
OPERATION MODE
TIMER SETTING
MAIN PARAMETER
INTERFACE SETTING
SERVICE INFORMATION
OK ENTER 1/2 ↕

Timer

Select TIMER using UP and DOWN and press OK.
 Press LEFT - RIGHT to select the value of the password
 Press UP - DOWN to enter the value of the password.
 The password is 123 and cannot be modified.

MENU
OPERATION MODE
TIMER SETTING
FUNCTION SETTING
MAIN PARAMETER
INTERFACE SETTING
SERVICE INFORMATION
OK ENTER 2/2 ↕

TIMER SETTING
PLEASE INPUT THE PASSWORD
0 0 0
OK ENTER ↕ ADJUST ↕

If the password is incorrect, the display will appear as follows:

TIMER SETTING
DAILY TIMER
WEEKLY SCHEDULE SETTING
WEEKLY SCHEDULE CHECK
CANCEL TIMER
OK ENTER ↕

Daily timer

Select DAILY TIMER with UP and DOWN and press OK .
 Press UP and DOWN to choose timer T1 - T5.
 Press ON/OFF to enable/disable the selected timer.
 Press LEFT - RIGHT to select each option to be set
 Press UP - DOWN to adjust the temperature and start/end time parameters.
 Press OK to confirm the setting and return to the previous page, or press BACK to delete the setting and return to the previous page .

DAILY TIMER				
NO.	Y/N	SET	START	END
T1	<input type="checkbox"/>	24C°	00:00	00:00
T2	<input type="checkbox"/>	24C°	00:00	00:00
T3	<input type="checkbox"/>	24C°	00:00	00:00
T4	<input type="checkbox"/>	24C°	00:00	00:00
T5	<input type="checkbox"/>	24C°	00:00	00:00
ON/OFF	SELECT			↕ ↕

<p>Weekly timer</p> <p>Select DAILY TIMER with UP - DOWN and press OK</p>																																				
<p>Press LEFT - RIGHT UP - DOWN to select the days. Press ON/OFF to confirm/delete the selected days After the selection, press OK to view the next page</p>																																				
<p>Press UP - DOWN to choose timer T1 - T5. Press ON/OFF to enable/disable the selected timer. Press LEFT - RIGHT to select each option to be set Press UP - DOWN to adjust the temperature and start/end time parameters. Press OK to confirm the setting and return to the previous page, or press BACK to delete the setting and return to the previous page.</p>	<table border="1"> <thead> <tr> <th colspan="5">DAILY TIMER</th> </tr> <tr> <th>NO.</th> <th>Y/N</th> <th>SET</th> <th>START</th> <th>END</th> </tr> </thead> <tbody> <tr> <td>T1</td> <td><input type="checkbox"/></td> <td>24C°</td> <td>00:00</td> <td>00:00</td> </tr> <tr> <td>T2</td> <td><input type="checkbox"/></td> <td>24C°</td> <td>00:00</td> <td>00:00</td> </tr> <tr> <td>T3</td> <td><input type="checkbox"/></td> <td>24C°</td> <td>00:00</td> <td>00:00</td> </tr> <tr> <td>T4</td> <td><input type="checkbox"/></td> <td>24C°</td> <td>00:00</td> <td>00:00</td> </tr> <tr> <td>T5</td> <td><input type="checkbox"/></td> <td>24C°</td> <td>00:00</td> <td>00:00</td> </tr> </tbody> </table>	DAILY TIMER					NO.	Y/N	SET	START	END	T1	<input type="checkbox"/>	24C°	00:00	00:00	T2	<input type="checkbox"/>	24C°	00:00	00:00	T3	<input type="checkbox"/>	24C°	00:00	00:00	T4	<input type="checkbox"/>	24C°	00:00	00:00	T5	<input type="checkbox"/>	24C°	00:00	00:00
DAILY TIMER																																				
NO.	Y/N	SET	START	END																																
T1	<input type="checkbox"/>	24C°	00:00	00:00																																
T2	<input type="checkbox"/>	24C°	00:00	00:00																																
T3	<input type="checkbox"/>	24C°	00:00	00:00																																
T4	<input type="checkbox"/>	24C°	00:00	00:00																																
T5	<input type="checkbox"/>	24C°	00:00	00:00																																
<p>Verification of the weekly schedule</p> <p>Select WEEKLY SCHEDULE CHECK in the TIMER menu</p> <p>The WEEKLY CHECK allows for viewing, but not modifying, the weekly schedule.</p> <p>Press UP - DOWN to shift from one day of the week to another.</p>	 <table border="1"> <thead> <tr> <th colspan="5">WEEKLY SCHEDULE CHECK</th> </tr> <tr> <th>DAY</th> <th>NO.</th> <th>SET</th> <th>START</th> <th>END</th> </tr> </thead> <tbody> <tr> <td rowspan="5">MON <input checked="" type="checkbox"/></td> <td>T1</td> <td><input checked="" type="checkbox"/> 24C°</td> <td>06:00</td> <td>08:00</td> </tr> <tr> <td>T2</td> <td><input checked="" type="checkbox"/> 24C°</td> <td>12:00</td> <td>14:00</td> </tr> <tr> <td>T3</td> <td><input checked="" type="checkbox"/> 24C°</td> <td>18:00</td> <td>20:00</td> </tr> <tr> <td>T4</td> <td><input checked="" type="checkbox"/> 24C°</td> <td>22:00</td> <td>22:30</td> </tr> <tr> <td>T5</td> <td><input checked="" type="checkbox"/> 24C°</td> <td>23:00</td> <td>23:50</td> </tr> </tbody> </table>	WEEKLY SCHEDULE CHECK					DAY	NO.	SET	START	END	MON <input checked="" type="checkbox"/>	T1	<input checked="" type="checkbox"/> 24C°	06:00	08:00	T2	<input checked="" type="checkbox"/> 24C°	12:00	14:00	T3	<input checked="" type="checkbox"/> 24C°	18:00	20:00	T4	<input checked="" type="checkbox"/> 24C°	22:00	22:30	T5	<input checked="" type="checkbox"/> 24C°	23:00	23:50				
WEEKLY SCHEDULE CHECK																																				
DAY	NO.	SET	START	END																																
MON <input checked="" type="checkbox"/>	T1	<input checked="" type="checkbox"/> 24C°	06:00	08:00																																
	T2	<input checked="" type="checkbox"/> 24C°	12:00	14:00																																
	T3	<input checked="" type="checkbox"/> 24C°	18:00	20:00																																
	T4	<input checked="" type="checkbox"/> 24C°	22:00	22:30																																
	T5	<input checked="" type="checkbox"/> 24C°	23:00	23:50																																

Verification of the weekly schedule

Select CANCEL TIMER in the TIMER menu
 Press OK to access
 Press YES to cancel all the settings of the daily and weekly timers.

TIMER SETTING	
DAILY TIMER	
WEEKLY SCHEDULE SETTING	
WEEKLY SCHEDULE CHECK	
CANCEL TIMER	
OK	ENTER 

AUTOMATIC TEMPERATURE

Select FUNCTION SETTING, press OK
 Press ON/OFF to enable/disable the function.
 Press OK to confirm or BACK to cancel the operation and return to the previous page .
 When AUTO TEMP. SETTING = ON, manual adjustment of the temperature is disabled.

FUNCTION SETTING	
AUTO TEMP. SETTING	OFF
SILENT MODE SETTING	NONE
FILTER CLEANING SETTING	
	ADJUST

15/07/2017 MON 10:35

THE AUTO TEMPERATURE
 SETTING FUNCTION IS ON.
 DO YOU WANT TO CANCEL THE
 AUTO TEMPERATURE SETTING
 FUNCTION?

YES NO

OK CONFIRM 

Shown to the side is the page that appears when the user attempts to modify the temperature manually.
 Press LEFT- RIGHT to select YES.
 Press OK to disable the AUTO TEMP. function and return to the previous page

SILENT MODE

Press MENU end select FUNCTION SETTING, press OK
 Press ON/OFF to enable/disable the function.
 Select SILENT MODE SETTING
 Press LEFT - RIGHT to choose the level: normal or super.
 Press BACK for return to the previous page .

FUNCTION SETTING	
AUTO TEMP. SETTING	OFF
SILENT MODE SETTING	NONE
FILTER CLEANING SETTING	
	ADJUST

INTERFACE SETTING

Press MENU end select INTERFACE SETTING
 Press OK to access
 Press UP - DOWN - LEFT - RIGHT end ON/OFF to confirm:
 Language = EN - FR - IT - ES - PL - PT - DE
 Back light
 Buzzer
 Time
 Date
 Screen lock time = Screen lock (time from 60 to 240 seconds) default 120sec

MENU
OPERATION MODE
TIMER SETTING
FUNCTION SETTING
MAIN PARAMETER
INTERFACE SETTING
SERVICE INFORMATION
OK ENTER 1/2 ↕

INTERFACE SETTING
BACK LIGHT ON
BUZZER ON
LANGUAGE EN (English)
TIME 12:00:00
DATE 01-01-2017
SCREEN LOCK TIME 120S
↕ ADJUST ↕

VISUALIZATION OF ALARMS

Press MENU end select SERVICE INFORMATION
 Select ERROR RECORD and insert PASSWORD 321
 Press OK to access
 Press UP - DOWN to scroll through the alarms (max 24 errors displayed, on the 25th error the 1st error will be eliminated)
 Press OK to see the description of the alarm.

SERVICE INFORMATION
SERVICE PARAMETER
ERROR RECORD
OK ENTER 1/1

ERROR RECORD
1 E1 14:50 01-01-2017
2 E1 14:40 01-01-2017
3 E1 14:30 01-01-2017
4 E1 14:20 01-01-2017
5 E1 14:10 01-01-2017
6 E1 14:00 01-01-2017
OK ENTER 1/4

ERROR RECORD
E1 The communication fault between main board and HMI
OK ENTER

Service information

Press MENU and select SERVICE INFORMATION
 Select SERVICE PARAMETER
 Press OK to access
 The menu is used by the installer or service technician to check the operating parameters.
 The parameters are displayed in the following 5 screens
 Press UP - DOWN to scroll.

MENU
OPERATION MODE
TIMER SETTING
FUNCTION SETTING
MAIN PARAMETER
INTERFACE SETTING
SERVICE INFORMATION
OK ENTER 1/2 ↓

SERVICE PARAMETER	
Operation mode	COOL
Compressor frequency	32HZ
Input current	4A
Input voltage	230V
Comp.run time	10H
Comp.start-up number	2500
Exv opening	240P
Supply fan speed level	3
Exhaust fan speed level	3
Supfan run time	1000H
Filter-cpt setting	10000H
Damper output	OFF
Aux-heater	ON
Aux-heater voltage output	5V
Humidfyer state	ON
Electrical filter state	1
Ts set temp.	24C°
T1 indoor temp.	35C°
T4 outdoor temp.	35C°
T2 supply air coil temp.	10C°
T2b supply air coil temp.	35C°
Tc supply air temp.	35C°
T3 exhaust air coil temp.	52C°
Tp comp.discharge temp.	85C°
Ursu SUPPLY AIR HUMIDITY	45%
Bms address	1
Main software	V09
Module E2 software	V09
Hmi software	V13

OPERATION PARAMETER

This menu OPERATION PARAMETER is for installer or service engineer reviewing the operation parameter.

The values shown on the screens are only indicative

Press MENU and select ASSISTANCE SETTING

Insert PASSWORD

Press OK

Select OPERATION PARAMETER

There are 3 pages for the operating parameters as following.

Press UP - DOWN to scroll

Press Adjust for modification

ASSISTANCE SETTING	
1. OPERATION PARAMETER	
2. HUMIDITY PARAMETER	
3. RESET COMP. START TIMES	
4. MANUALLY DEFORST	
5. ERROR RECORD REMOVE	
6. CANCEL ASSISTANCE SETTING	
OK	ENTER

1. OPERATION PARAMETER	
1. 01 AUTOText0	15°C
1. 02 AUTOText1	24°C
1. 03 AUTOSet0	19°C
1. 04 AUTOSet1	25°C
1. 05 EnOnOff	1
1. 06 EnMode	1
ADJUST	1/3

1. OPERATION PARAMETER	
1. 07 DeadZone	2°C
1. 08 EnAuxHeater	0
1. 09 MaxAnAuxHeater	100%
1. 10 TempAnAuxEn	5°C
1. 11 TimecompAux	20 min
1. 12 SupFanSet	6
ADJUST	2/3

1. OPERATION PARAMETER	
1. 13 OffsetT1	0°C
1. 14 PoweroffMem	1
1. 15 BMSAddSet	1
1. 16 EnEfilter	0
1. 17 EnHumidifier	0
ADJUST	3/3

DEHUMIDIFICATION SETTING

Press MENU and select ASSISTANCE SETTING

Insert PASSWORD

Press OK

Select Humidity parameter

Enable parameter: 2.01 EnProbeUrSup =1

Set parameter: 2.03 DehumComModeSet (value 0,1,2)

0 = standard (10g/kg)

1 = Low humidity (8g/kg)

2 = eco (12g/kg)

DEHUMIDIFICATION (FROM MODBUS)

Enable from parameter keyboard: 2.01 EnProbeUrSup =1

Modbus:

Set parameter: 222 DehumComModeSet (value 0,1,2)

0 = standard (10g/kg)

1 = Low humidity (8g/kg)

2 = eco (12g/kg)

2. HUMIDITY PARAMETER	
2. 01 ENProbeUrSu	0
2. 02 OffsetUrSu	0%
2. 03 DehumConModeSet	0
2. 04 HumCorrFanSpe	1
ADJUST	1/1

<p>RESET COMPRESSOR START TIMES</p> <p>To cancel the number of compressor starts and the compressor operating time. Select YES, press OK to confirm</p>	
<p>MANUALLY DEFROST</p> <p>To start manual defrosting of the unit. Select YES, press OK to confirm</p>	
<p>ERROR CODE REMOVE</p> <p>To clear all alarms Select YES, press OK to confirm</p>	
<p>CANCEL ASSISTANCE SETTING</p> <p>Reset all the factory set parameters. Select NO, press OK to return to the previous page . Select YES, press OK to confirm</p>	

NETWORK CONFIGURATION GUIDELINES

The wired controller realizes intelligent control with a built-in module, which receives control signal from the APP.

Before connecting the WLAN, please check for it if the router in your environment is active and make sure that the wired controller is well-connected to the wireless signal.

During the Wireless distribution process, the LCD icon WI-FI flashes to indicate that the network is being deployed. After the process is completed, the icon WI-FI will be constantly on.

WIRED CONTROLLER SETTING

The wired controller settings include AP MODE and RESTORE WLAN SETTING.

Activate the WLAN by interface.

Go to MENU > WLAN SETTING > AP MODE.

Press "OK", the following page will appear

Press **LEFT** , **RIGHT**, to move to "YES" , press "OK" to select AP mode.

Select AP Mode correspondingly on the mobile device and continue the follow-up settings according to the APP prompts.

Caution

After enter Ap mode, if it's not connected with mobile phone, the LCD icon WI-FI will flash 10 minutes then disappear.

If it's connected with the mobile phone, the icon WI-FI will be constantly display.

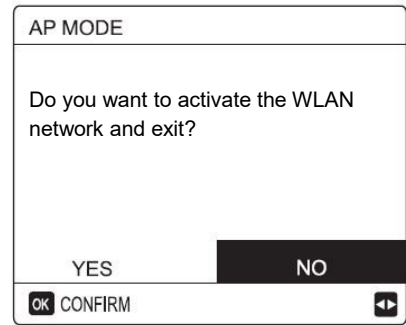
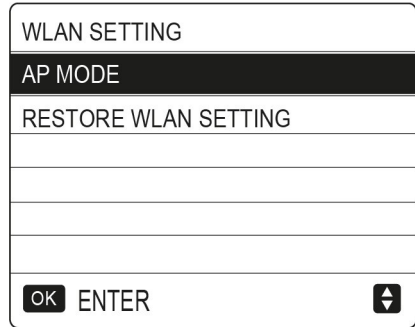

Restore WLAN setting by interface.

Go to MENU > WLAN SETTING > RESTORE WLAN SETTING .

Press"OK", the following page will appear

Press **LEFT** , **RIGHT**, to move to "YES", press "OK" to restore WLAN setting. Complete the above operation and wireless configuration is reset.

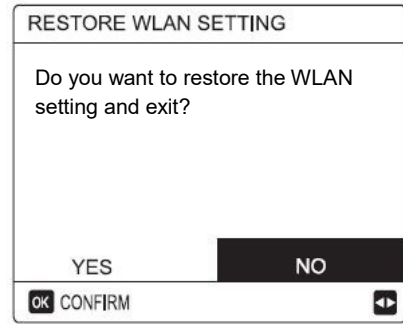

MOBILE DEVICE SETTING

AP Mode is available for wireless distribution on mobile device side.

AP Mode connecting WLAN:

- Install APP
- Scan the following QR code to install the Smart Home APP.
- Please research "Msmartlife" in APP STORE or GOOGLE PLAY to install the APP.



SIGN IN/SIGN UP

Click the "+" button on the right side of the home page , register account according to the guide.

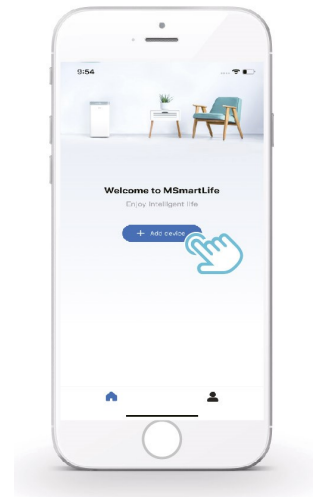

Add Home Appliances

1) Choose the “Fresh air” model, then go to add the device.



2) Operate the wired controller according to APP prompts.

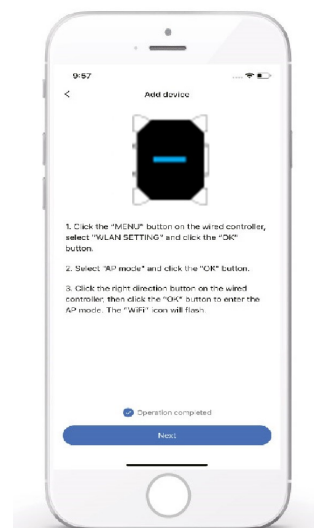

3) Wait for the home appliance to connect, and click “Finish”.

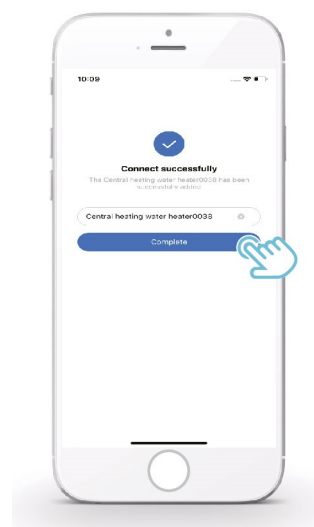



4) After the appliance is successfully connected, the LCD icon WIFI of the wired controller is constantly on, and the air conditioner can be controlled through the APP.

5) If the network distribution process fails, or the mobile connection demands reconnection and replacement, operate "WiFi Factory Reset" on the wired controller, and then repeat the above process.

WARNING AND TROUBLESHOOTING FOR NETWORKING FAILURES

- When the product is connected to the network, please make sure that the phone is as close as possible to the product.
- We only support 2.4GHz band routers at present.
- Special characters (punctuation, spaces, etc.) are not recommended as part of the Wifi name.
- It is recommended that you connect no more than 10 devices to a single router lest home appliances are affected by weak or unstable network signal.
- If the password of the router or Wifi is changed, clear all settings and reset the appliance.
- The contents of APP might change in version updates and actual operation shall prevail.



WI-FI network access from mobile phone

Select the WI-FI network similar to midea-xx-xxxx

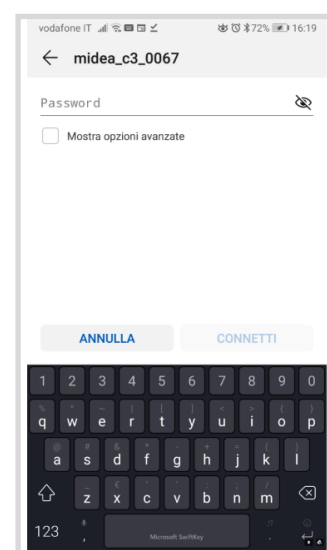
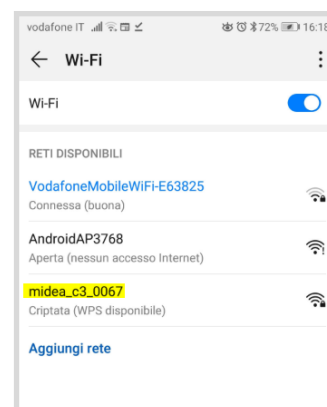
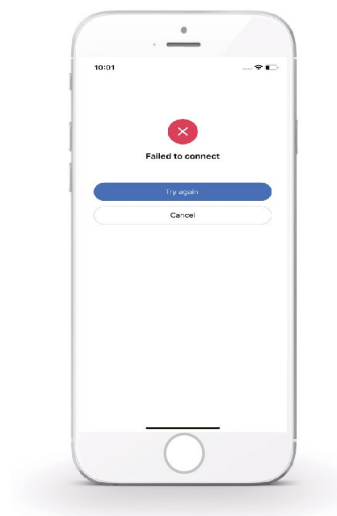
Enter password: 12345678



APP FUNCTIONS

-  Unit On / off
-  Mode change :
 - Cool
 - Heat
 - AutoSet
 - Auto
 - Fan

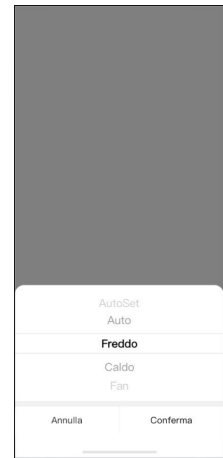
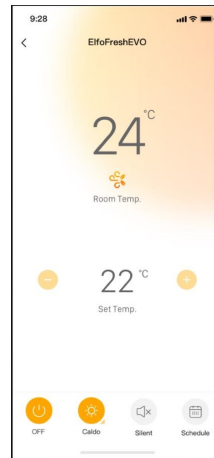

SILENT MODE

Press: 

- Select silent mode:
- Normal silent
 - Super silent

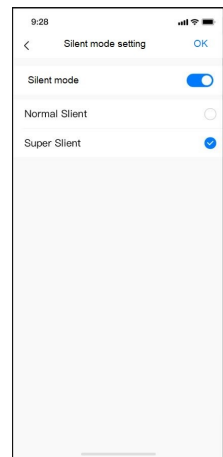
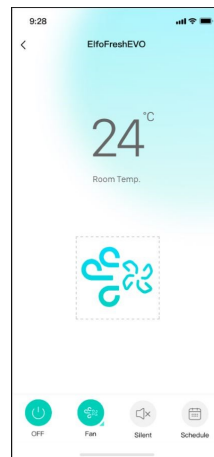

SCHEDULING

Press: 

- Select :
- Daily timer
 - Weekly

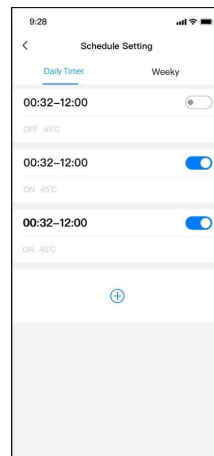

SCHEDULING

Weekly

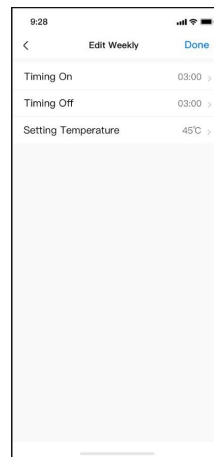
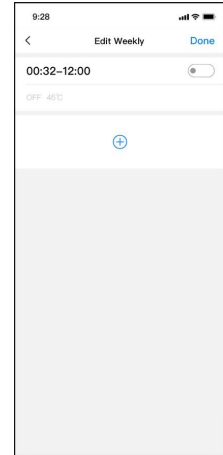
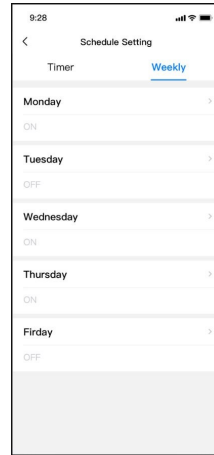



ALLARMS

In case of maloperations the alarms are indicated by the 'Alarm in progress' symbol on the multifunctional keypad.

To view the alarms select Menu ► Service information

To reset the alarm remove its cause and reset the active alarm.

Before resetting an alarm identify and remove the cause that generate it.

Repeated reset can cause irreversible damages as maloperation of the system itself.

In case of doubt please contact an Assistance Centre.

Code	Modbus code	Description	Error type
E0	1	Main PCB EPROM fault	C
E1	2	The communication fault between main board and HMI	C
E2	3	T2 probe fault	B
E3	4	TC probe fault	C
E4	5	T3 probe fault	B
E5	6	T1 probe fault	B
E6	7	T4 probe fault	B
E7	8	Water level switch fault	B
E8	9	Module Board E Square type error fault	B
EE	10	Module Board E Square error fault	B
E9	11	T2B probe fault	B
EA	12	Tp probe fault	B
Eb	13	EXV coil fault	B
EU	14	URsu probe fault	A
H0	15	Communication fault of IPM module	B
H1	16	Low voltage protection	C
H2	17	High voltage protection	C
H4	18	3 times Module protections happed in 60 minutes, It needs to be re-energized to recover	B
H5	19	3 times LOW pressure protection happed in 60 minutes. It needs to be re-energized to recover	B
H9	20	3 times P9 protections happed in 60 minutes, It needs to be re-energized to recover	C
HA	21	3 times PA protections happed in 60 minutes It needs to be re-energized to recover	C
C1	22	protection about T1 temperature too high	B
C2	23	protection about T1temperature too low	B
C3	24	Filter alarm	A
C4	25	protection about TC temperature too high	B
C5	26	protection about TC temperature too low	B

8 - CONTROL

C6	27	protection about T4 temperature too high	C
C7	29	protection about T4temperature too low	C
P0	30	High discharge temperature protection	B
P1	31	High pressure protection	B
P2	32	Low pressure protection	B
P4	33	High current protection	B
P5	34	High T3 temperature protection in cooling mode	B
P7	35	High T2 temperature protection in heating mode	B
P9	36	SUPPLY DC fan protection	C
PA	37	EXHAUST DC fan protection	C
PP	38	Insufficient protection of discharge superheat	B
L0	39	Module protection	C
L1	40	Low Voltage Protection	C
L2	41	High Voltage Protection	C
L3	42	Reserved	C
L4	43	MCE fault	C
L5	44	Zero speed protection	C
L6	45	Reserve	C
L7	46	Phase loss	C
L8	47	Frequencies change more than 15 Hz	C
L9	48	Frequency difference 15 Hz	C
LA	49	Compressor Overcurrent/Overload Protection	C
LC	50	Compressor Current Sampling Circuit Fault (Reserved)	C
LH	53	Compressor Start-up Failure (Reserved)	C
CA	54	Electric Auxiliary Heat Fault , It needs to be re-energized to recover	A
CB	55	Installation of Tc Sensor and T4 Sensor	B
CC	56	Electrical Filter Fault, It needs to be re-energized to recover	A

code **A** indicates the presence of an anomalous situation that does not affect the unit operation

code **B** indicates the unit compressor stop.

code **C** indicates the unit total stop

PASSWORD-PROTECTED UNIT PARAMETERS (INSTALLER USE)
ATTENTION

The access to parameters or modifications are allowed only to the installer who assumes all responsibility, in case of doubts please contact Clivet.

For any changes not permitted or not approved by Clivet, the same declines any responsibility for malfunctions and/or damages to the unit/system.

* No.	Code	Description	default	Minimum	maximum	unit
1.01	AUTOText0	Auto T1s setting temperature X- 0	15	0	50	°C
1.02	AUTOText1	AUTOText1> AUTOText0+2	24	0	50	°C
1.03	AUTOSet0	Auto T1s setting temperature Y- 0	19	0	50	°C
1.04	AUTOSet1	Auto T1s setting temperature Y- 1 AUTOSet1> AUTOSett0+2	25	0	50	°C
1.05	EnOnOff	Unit ON/OFF: 0 : remote ON/OFF 1: HMI control	1	0	1	-
1.06	EnMode	Mode setting: 0 : ON/OFF setting , ON= heating, OFF= cooling 1 : HMI control	1	0	1	-
1.07	DeadZone	Auto mode the temperature difference between change cooling and heating mode	2	1	10	°C
1.08	EnAuxHeater	Electrical heater: 0: without electrical heater 1: with electrical heater	0	0	1	-
1.09	MaxAnAuxHeater	Maximum electrical heater output	100	50	100	%
1.10	TempAmAuxEn	ODU temperature to start the electrical heater	5	-10	15	°C
1.11	TimecomAux	The minimum compressor running time before start the electrical heater	20	10	120	min
1.12	SupFanSet	Supply fan speed setting	6	3	7	-
1.13	OffsetT1	Return air temperature correction				%
1.14	PoweroffMem	Power-down memory function 1 : with; 0 : without	1	0	1	-
1.15	BMSAddSet	BMS	1	1	16	-
1.16	EnEfilter	Electrical filter: 0 : none 1 : yes	0	0	1	-
1.17	EnHumidifier	Humidifier 0 : none 1 : yes	0	0	1	-

8 - CONTROL



2.01	EnProbeUrSup	Supply air humidity sensor (enable or disable)	1	0	1	-
2.02	OffsetUrSup	Supply air humidity sensor offset	0	-50	50	%
2.03	DehumConModeSet	Dehumidity function setting: 0 means Standard humidity 1 means Low humidity 2 means Eco mode	0	0	2	-
2.04	HumCorrFanSpe	Humidity control to fan speed setting: 1 means supply fan speed will be changed to follow humidty control function, 0 means supply fan speed will NOT be changed to follow humidity control function	1	0	1	-

MODBUS COMMUNICATION

The unit can be connected to ELFOControl³ EVO or an external supervisor system.

Elfocontrol³ EVO (option)

Equipped with:

- 12Vdc AL12X feeder
- Ethernet/485 converter
- Ethernet UTP cat.5 cable (5 m long)

For details, see instructions ELFOControl³ EVO manual

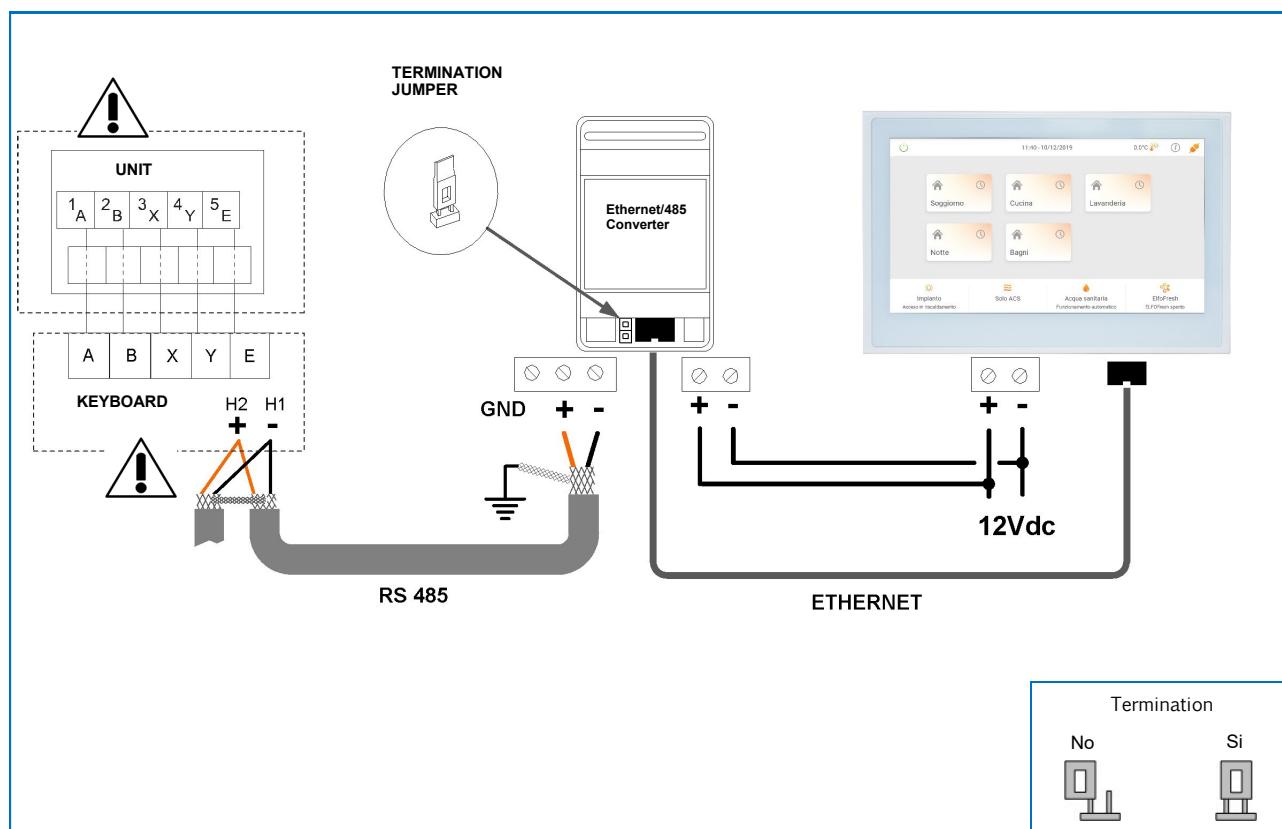

Modbus connection

Baud rate = 9600

Length = 8

Parity = none

Stop bit = 1

ModBus protocol details: following pages.

8 - CONTROL

Operation parameter(writable and readable)		
Register address	Content	Parameter range and its meaning
0	Power on/off	BIT0 0: OFF 1: ON
1	Mode setting	1: Cool 2: Heat 3: Fan 4: Auto
2	T1s Setting temperature	17~28°C
3	Functions setting	BIT0: Silent mode
		BIT1: 0 normal silent mode, 1 super silent miode
		BIT2: Auto T1s setting function

Operation parameter(only readable)		
100	Operating rps	Compressor rps HZ
101	Mode	0: off 1: cooli 2: heat 3: fan
102	Supply fan speed	0~9
103	Exhaust fan speed	0~9
104	EXV opening	0-480P
105	Tc	Tc temperature (-25~70)°C
106	RHC supply air reality humidty	0~100%
107	T3	T3 Temp (-25~70)°C
108	T4	T4 Temp (-25~70)°C
109	TP	Tp Temp (-25~70)°C
110	TH	Th Temp (-25~70)°C
111	T1	T1 Temp (-25~70)°C
112	T2	T2 Temp (-25~70)°C
113	T2B	T2B Temp (-25~70)°C
116	current	0.1 A
117	voltage	V
118	Compressor stop/run time	Stop or running time, second
119	Current error	
120	History error1	
121	History error 2	
122	History error 3	
123	Unit size	1-3 size1, size 2, size 3

8 - CONTROL



124	Operating mode	BIT1 : deforst BIT2 : silent mode BIT3 : oil return BIT4 : remote ON/OFF BIT8 : water level switch alarm ON BIT11 : damper is ON when it is 1, damper is OFF it is OFF. BIT12 : humidfier ON
125	Output status	BIT0 : electrical filter BIT1 : gas deforst (reserved) BIT2 : water pump BIT3 : humidifier BIT4 : 4-way valve BIT5 : exhaust fan power BIT6 : supply fan power BIT7 : system error BIT8 : unit ON index, BIT9 : electrical heater (optional) BIT10 : deforst index
126	Electrical heater output percent	0~100% (0~10V)
127	Main software version	
128	HMI software version	
129	T1s Setting temperature	°C
130	Module Eprom version	
131	Module Eprom version	

Setting parameters (readable and writable)			
Register address	Item	Range	Default number
200	AUTOText0	0~50	15
201	AUTOText1	0~50	24
202	AUTOSet0	17~28	19
203	AUTOSet1	17~28	25
204	EnOnOff	0~1	1
205	EnMode	0~1	1
207	DeadZone	1~10	2
208	TempAmAuxEn	-10~15	5
209	TimecomAux	10~120	20
210	SupFanSet	3~7	6
211	EnProbeUrExt	0~1	0
212	EnProbeUrSup	-50~50	0
213	OffsetUrSup	0~1	0
214	OffsetUrAmb	-50~50	0
215	EnAuxHeater	0~1	0
216	MaxAnAuxHeater	50~100	100
217	SlientMode	0~2	0
218	OffsetT1	-10~10	0
219	EnAutoTemp	0~1	0
220	BMSAddSet	1~16	1
221	PoweroffMem	0~1	1
222	DehumConModeSet	0~2 (0=STD, 1=low;2=eco)	0
223	HumCorrFanSpe	0~1	0
224	EnEFilter	0~1	0
225	Humidifier	0~1	1

CLEANING

Filters and inlets/outlets must be cleaned to ensure optimal operation of the system.

Visually inspect the level of clogging.

The device should be visually inspected frequently and cleaned at least every 6 months.

Check the filter: replace if very dirty or wash it with water

To clean:

- clean in tepid water with common detergent.
- rinse thoroughly in running water to avoid spillage into the served area.

- dry

Alternatively:

- blowing or vacuuming

Outlet grille

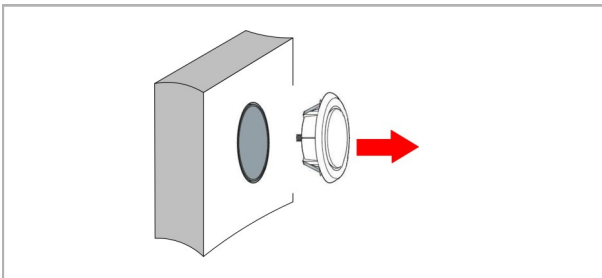

Replacement of inlet filter (VIEX)

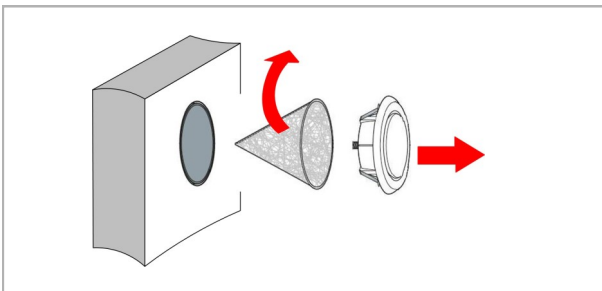

Replacement of rectangular grille filter (GINOX-GIVEX)

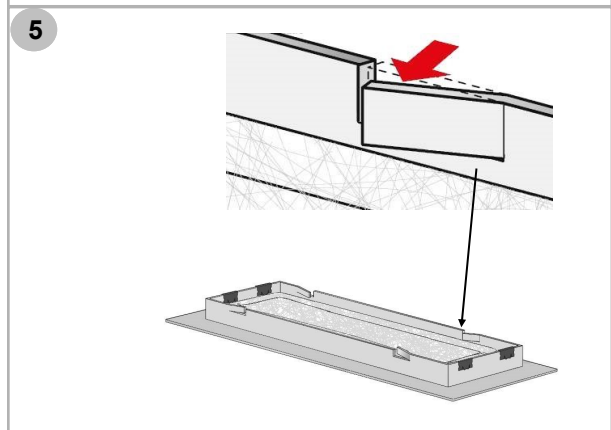
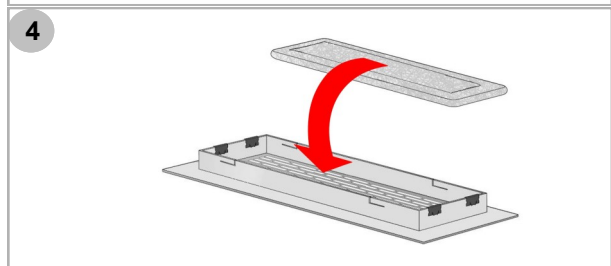
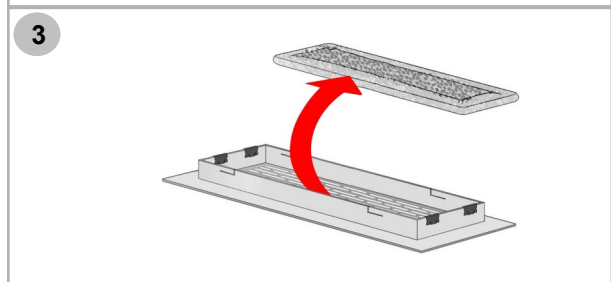
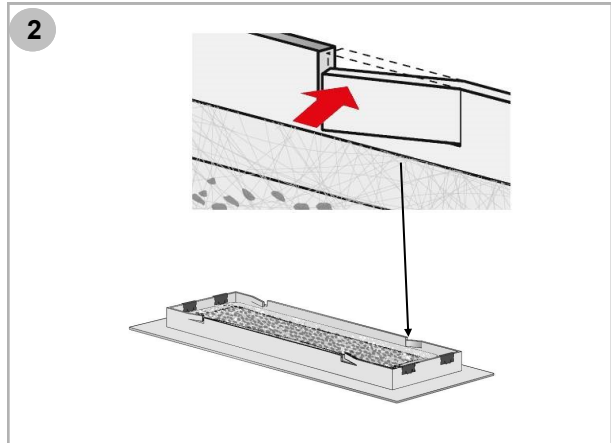
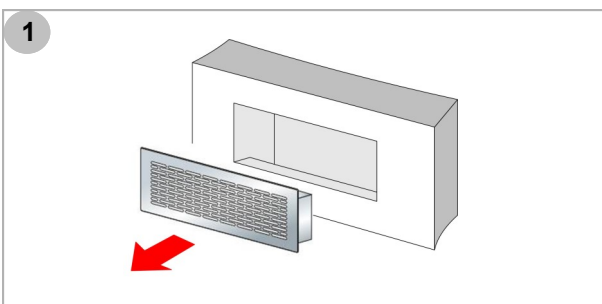

Square grille metal filter (GQIEX)

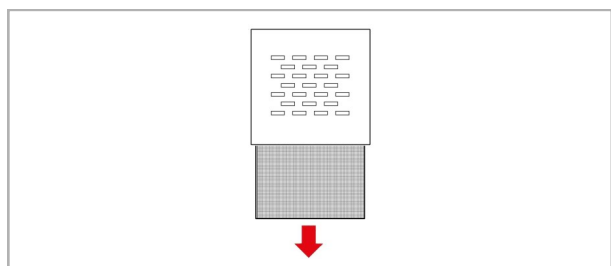

Extraction grille regenerable filter (GAIR50/80X)

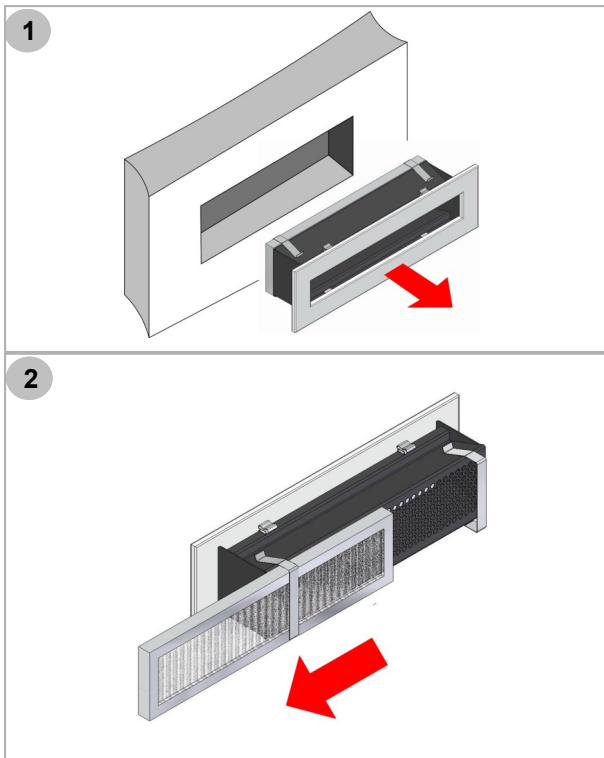

⚠ Check for air filters on vents/inlet grilles before switching on the unit, otherwise the entire air distribution system may become dirty.

SAFETY WARNINGS FOR OPERATIONS ON UNITS CONTAINING R32

Area checks

Before working on systems containing flammable refrigerants, perform safety checks to reduce the risk of combustion to the minimum. Before performing any reparation operations on the cooling system, comply with the following warnings.

Work procedures

Operations must be performed following a controlled procedure so as to reduce the risk of flammable gases or vapours developing.

General work area

All the personnel in charge with maintenance operations and other operators working in the local area must be instructed and monitored as regards the nature of the intervention.

Avoid working in tight spaces. The area surrounding the working space must be cordoned off. Make sure the area is secured by monitoring the flammable material.

Check the presence of refrigerant

Both before and during operations, the area must be monitored with a dedicated refrigerant detector to make sure the technician is aware of the presence of potentially-flammable environments.

Make sure the leak detection equipment is suitable for use with flammable refrigerants and therefore without sparks, suitably sealed or intrinsically safe.

Presence of the fire extinguisher

If hot interventions are not performed on cooling equipment or connected components, suitable fire fighting equipment must be kept at hand.

Keep a dry-powder or CO₂ extinguisher near the loading area.

No ignition source

It is absolutely forbidden to use ignition sources that may lead to fire or explosion during operations on the cooling system or on pipes that contain or have contained flammable refrigerant.

All possible ignition sources, including cigarettes, must be kept sufficiently away from the installation, reparation, removal and disposal site as flammable refrigerant may be released in the surrounding area.

Before starting operations, the area surrounding the equipment must be inspected to guarantee the absence of flammables or combustion risks.

“SMOKING IS FORBIDDEN” signs must be affixed.

Ventilated area

Before intervening on the system or performing any hot intervention, make sure to be in an outdoor or suitably ventilated area.

Ventilation must be maintained during operations. Ventilation must disperse the released refrigerant safely, preferably outdoors in the atmosphere.

Cooling equipment checks

Should a replacement be necessary, the new components installed must be suitable for the purpose envisaged and compliant with specifications.

Always follow the manufacturer guidelines on maintenance and assistance. In case of doubt, contact the manufacturer technical office for assistance.

The following checks must be performed on systems containing flammable refrigerants:

- the quantity of the charge must comply with the size of the room where the parts containing refrigerant are installed;
- the machine and ventilation intake function correctly and are not obstructed;
- If an indirect cooling circuit is used, the secondary circuits must be checked to verify the presence of refrigerants; the marking on the equipment remains visible and readable;
- Make sure markings and symbols are always readable; cooling pipes or components must be installed in a position that makes improbable their exposure to substances that may corrode the components containing refrigerant, unless they are manufactured with material intrinsically resistant to corrosion or suitably protected against corrosion.

Electrical device checks

The reparation and maintenance of electric components must include initial safety checks and component inspection procedures.

In case of a fault that compromises safety, do not perform any electrical connection to the circuit until said fault is suitably resolved.

If it is not possible to repair the fault immediately and electrical components need to remain functioning, a temporary solution must be adopted. This must be reported to the owner of the equipment so as to keep all parties informed.

Initial safety checks must include:

- that condensers are emptied. This operation must be performed safely to avoid any sparks;
- that electrical components and wiring are not exposed during the charging, recovering or venting phases;
- That the earth conductor is continuous.

SAFETY WARNINGS FOR OPERATIONS ON UNITS CONTAINING R32

Repairing sealed components

- During the reparation operations of sealed components, disconnect all the equipment before removing sealed casings etc. If, during operations, it is absolutely necessary for the equipment to remain connected, a leak detection device must be placed in the most critical point so as to report any potentially-dangerous situation.
- Pay particular attention to what follows to guarantee that, while intervening on electrical components, the housing is not altered in a way so as to affect the level of protection. This includes damage to cables, an excessive number of connections, terminals not compliance with the original specifications, damage to gaskets, an unsuitable installation of gaskets, etc.
- Make sure the device is installed safely.
- Check that the seals or sealing materials are not altered in such a way that they no longer impede the entry of flammable environments. Spare parts must comply with manufacturer specifications.

NOTE:

⇒ *Using silicone sealants may inhibit the effectiveness of a few types of leak detection equipment. It is not necessary to isolate intrinsically safe components before performing operations on them.*

Reparation of intrinsically safe components

Do not apply permanent inductive or capacitive loads to the circuit without making sure that they do not exceed the admissible voltage and current allowed for equipment in use.

Intrinsically safe components are the only component type on which operations can be performed in a flammable atmosphere. The testing device must show a correct value. Replace components only with the parts specified by the manufacturer.

Following a leak, other parts could lead to the combustion of the refrigerant in the atmosphere.

Wires

Make sure wires are not subjected to wear, corrosion, excessive pressure or vibration, that there are no sharp edges and that they do not produce other negative effects on the environment. The inspection must also keep into consideration the effects of time or the continuous vibration caused e.g. by compressors or fans.

Detection of flammable refrigerants

Under no circumstance is it possible to use potential ignition sources to search or detect refrigerant leaks.

Do not use halide lights (or any other open flame detectors).

Leak detection methods

The following leak detection methods are considered acceptable for systems containing flammable refrigerants. Electric leak detectors must always be used to identify flammable refrigerants, although they do not present a suitable sensitivity level or require recalibration (detection equipment must be calibrated in an area free from refrigerants).

Check that the detector is not a possible source of ignition and that it is suitable for the refrigerant. Leak detection equipment must always be set to an LFL percentage and calibrated depending on the refrigerant used, so the correct gas percentage (25% max) must be verified.

Leak detection fluids are suitable for most refrigerants, although using detergents containing chlorine should be avoided as this substance may react with the refrigerant and corrode copper pipes.

If a leak is suspected, all open flames must be removed or switched off.

If a leak is identified that requires brazing, all the refrigerant must be recovered from the system or isolated (using interception valves) in a section of the system far away from the leak. Oxygen-Free-Nitrogen (OFN) is then purged through the system both before and during the brazing procedure.

Removal and evacuation

When intervening on the cooling circuit to perform repair work or any other type of work, always follow the normal procedure. However, considering the risk of flammability, we recommend following the best practices. Comply with the following procedure:

- remove the refrigerant;
- purge the circuit with inert gas;
- evacuate;
- Purge again with inert gas;
- Interrupt the circuit with interruption or brazing.

The refrigerant charge must be collected in suitable recovery tanks. To make the unit safe, flushing with Oxygen-free-Nitrogen must be performed. This procedure may have to be repeated multiple times. Do not use compressed air or oxygen for this operation.

Flushing is obtained interrupting the system vacuum with OFN and filling until the operating pressure is obtained, then releasing into the atmosphere and restoring the vacuum. This process must be

SAFETY WARNINGS FOR OPERATIONS ON UNITS CONTAINING R32

repeated until there is no trace of refrigerant in the system.

When using the final OFN charge, the system must be vented to the atmospheric pressure to allow the intervention. This step is essential to perform

brazing operations on the pipes.

Make sure that the vacuum pump intake is not near ignition sources and that there is suitable ventilation.

Charging operations

In addition to conventional charging operations, the following requirements must be complied with:

- When using charging equipment, make sure that the various refrigerants are not contaminated. Flexible tubes or conduits must be as short as possible to reduce to the minimum the quantity of refrigerant contained.
- Tanks must be kept in a vertical position.
- Before loading the system with refrigerant, check that the cooling system is earthed.
- Label the system when fully charged (unless already labelled).
- Make sure not to fill the cooling system excessively.
- Before recharging the system, the pressure must be tested with OFN. A leak test must be performed after the charging operations but before commissioning. Before leaving the site, perform an additional leak test.

Dismantling

Before performing this procedure, it is essential that the technician has become familiar with the equipment and the relative details.

We recommend employing good practices for a safe recovery of the refrigerants.

Before performing the operation, take a sample of oil and refrigerant should an analysis be necessary before reusing the regenerated refrigerant. Before performing the operation, check the availability of electricity.

- Become familiar with the equipment and how it functions.
- Electrically isolate the system.

Before attempting the procedure, check that:

- The mechanical manipulation equipment is available, if necessary, to handle refrigerant tanks;
- All the personal protection equipment is available and employed correctly;
- The recovery procedure is monitored at all times by skilled personnel;

- The recovery equipment and tanks comply with suitable standards.
- If possible, pump the cooling system.
- If it is not possible to obtain a vacuum, make sure that a collector removes the refrigerant from various parts of the system.
- Before proceeding with the recovery, check that the tank is located on the scales.
- Start up the recovery machine and use it following the instructions by the manufacturer.
- Do not fill the tanks excessively. (Do not exceed 80% of the liquid volume).
- Do not exceed the tank's maximum operating pressure, not even momentarily.
- Once the tanks are filled correctly and the process is over, make sure that the tanks and equipment are immediately removed from the site and that all insulation valves on the equipment are closed.
- The refrigerant recovered must not be loaded into another cooling system unless it has been cleaned and checked.

Labelling

Equipment must be labelled reporting the dismantling and emptying of the refrigerant.

Labels must be dated and signed.

Make sure all the equipment is labelled and reporting the presence of flammable refrigerant.

Recovery

When removing the refrigerant from the system, please adopt good practices to remove all refrigerants safely in case of both assistance or decommissioning operations.

When transferring the refrigerant into the tanks, make sure only suitable tanks are used to recover the refrigerant.

Make sure enough tanks are used.

All the tanks to be used are designated for the recovered refrigerant and are labelled for that specific refrigerant (e.g. special tanks for refrigerant collection).

Tanks must be equipped with a perfectly-functioning safety valve and relative interception valves.

Empty recovery tanks are evacuated and, if possible, cooled before recovery.

Recovery equipment must be perfectly functioning with the respective instruction booklets at hand and they must be suitable to recover flammable refrigerants. A series of perfectly-functioning calibrated scales must also be available.

Flexible tubes must be equipped with leak-proof disconnection fittings in good condition. Before

SAFETY WARNINGS FOR OPERATIONS ON UNITS CONTAINING R32

using the recovery machine, make sure it is in good condition, maintained and that all associated electrical components are sealed to avoid combustion in case of a refrigerant leak. Please contact the manufacturer in case of doubt.

The refrigerant recovered must be taken to the supplier in suitable recovery tanks and with the relative waste transfer note suitably filled in.

Do not mix the refrigerants in the recovery units nor in the tanks.

If it is necessary to remove compressors or compressor oils, make sure they are evacuated to an acceptable level to make sure no trace is left of the flammable refrigerant inside the lubricant. The evacuation process must be performed before taking the compressors back to the suppliers.

The electric resistance must be used with the compressor body only to accelerate this process.

Operations to discharge the oil from the system must be performed in full safety.

Transport, mark and storage

- 1 Transport of equipment containing flammable refrigerants
Compliance with transport regulations
- 2 Marking of equipment with symbols
Compliance with local regulations
- 3 Disposal of equipment employing flammable refrigerants
Compliance with national regulations
- 4 Storage of equipment/devices
The equipment must be stored in compliance with the instructions provided by the manufacturer.
- 5 Storing packed (unsold) equipment
Packing must be performed in such a way that mechanical damage to the equipment inside it does not cause refrigerant leaks.
The maximum number of elements that can be stored together is determined by local regulations.

GENERAL

Maintenance must be done by authorized centres or by qualified personnel

The maintenance allows to:

- maintain the unit efficiency
- reduce the deterioration speed to whom every equipment is subject over time
- assemble information and data to understand the state of the unit efficiency and avoid possible damages

Before checking, please verify the following:

- the electrical power supply line should be isolated at the beginning
- the unit isolator is open, locked and equipped with the suitable warning
- make sure no tension is present

 After turning off the power, wait at least 5 minutes before accessing to the electrical panel or any other electrical component.

 Before accessing check with a multimeter that there are no residual stresses.

INSPECTIONS FREQUENCY

Perform an inspection every 6 months minimum.

The frequency, however, depends on the use.

 In the event of frequent use it is recommended to plan inspections at close intervals:

- frequent use (continuous or very intermittent use, near the operating limits, etc)
- critical use (service necessary).

UNIT BOOKLET

It's advisable to create a unit booklet to take notes of the unit interventions.

In this way it will be easier to adequately note the various interventions and aid any troubleshooting.

Report on the booklet:

- data
- type of intervention effected
- intervention description
- carried out measures etc.

PUT AT REST

If a long period of inactivity is foreseen:

- put the unit in OFF
- wait a few minutes to allow all the actuators to reach the rest position
- Turn off the power in order to avoid electrical risks or damages by lightning strikes

It's recommended that the starting-up after the stopping period is performed by a qualified technician, especially after seasonal stops or seasonal switch.

When restarting, refer to what is indicated in the START-UP section.

Schedule technical assistance in advance to avoid hitches and to guarantee that the system can be used when required.



STRUCTURE CLEANING

The structure of the unit is done in plastic material EPP (expanded polypropylene)

HBF fire resistance classification.

For cleaning the structure it is recommended to use products without aggressive chemicals.

ELECTROSTATIC FILTER

How often the filters need to be checked depends on the quality of outdoor air.

Approximately, cleaning should ideally take place from half-yearly to quarterly.

It is advisable to start with frequent checks, and to adjust the frequency based on how much dirt is discovered.

The most common contaminants for which the filter is designed are : air pollution by PM10, PM 2,5 and PM1.

Contaminants that can be filtered:

- dry smokes
- powder (up to 0.3 microns)
- smoke electrostatically charged

Contaminants that can NOT be filtered:

- water vapours also in low concentration
- oil vapours
- large amounts of dust
- metal shavings, iron filing dusts and waste generally
- gas

Absolutely to avoid:

- metal dusts also fine
- fumes produced by combustion of organic and not materials (wood, coal, gasoline, etc.)



! Switch off the unit.

Filter extraction

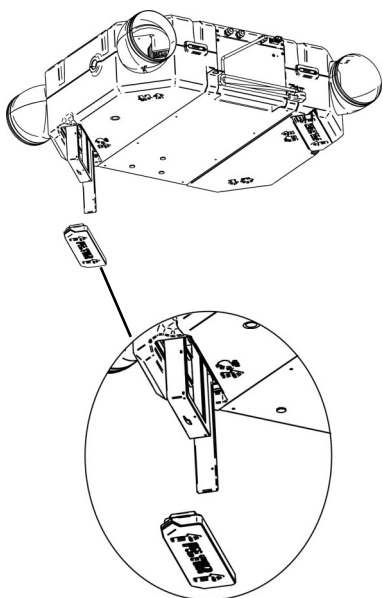
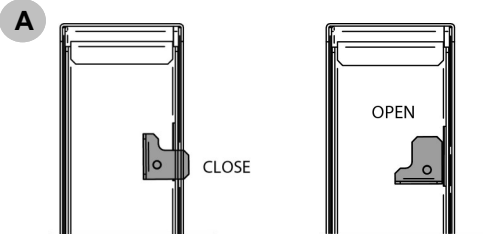
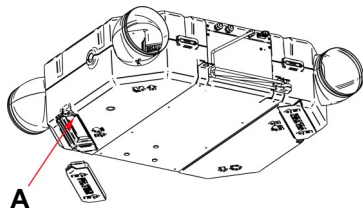
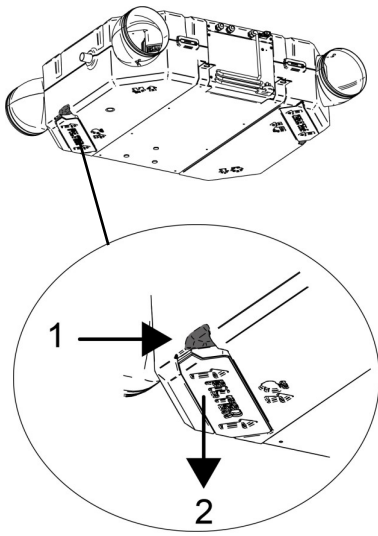

Dimension

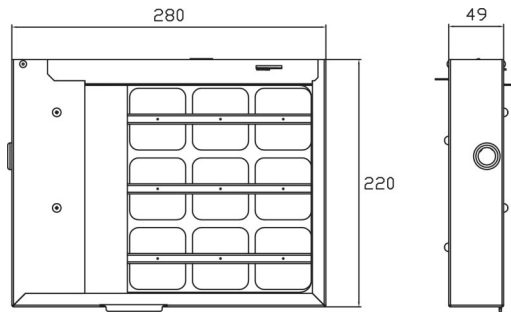

Cleaning of the electrostatic filter

Position the filter to be washed on a support to facilitate work.

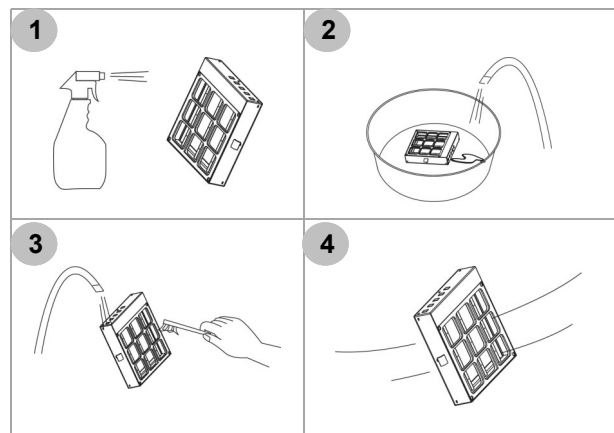

- 1 Spray neutral detergent + water on the filter and leave for 15 minutes.
- 2 Immerse the filter in water for no more than 3 to 5 minutes
- 3 Rinse the filter with water and at the same time clean with a soft brush.
- 4 Dry in a well-ventilated place.

Caution

- If a detergent is used to clean the filter, it must be rinsed thoroughly without leaving any residues.
- Do not use water hotter than 50°C
- Do not use air hotter than 50°C (it can damage the filter)

Note

- The filter may not return to its original colour after cleaning. This is normal and does not affect the filter's performance.
- If the filter is not completely dry after cleaning, its performance will be affected if there is a small amount of water left inside.
- Always dry it thoroughly before installation and use.

AIR FILTERS

! It is very important for the air treatment coil to be able to offer maximum thermal exchange. Therefore, the unit must always operate with the filters installed and clean.

Cleaning and replacement of filters are very important in terms of health and hygiene.

The operating with clogged filters leads to a reduction of the air flow, leading to malfunctions and unit shutdowns.

How often the filters need to be checked depends on the quality of outdoor air, unit operating hours, dust and number of persons in the rooms.

Approximately, cleaning should ideally take place between weekly and monthly. It is advisable to start with frequent checks, and to adjust the frequency based on how much dirt is discovered.

Old filters must be disposed of, according to the law in force .

! **The filter is replaced after 2500 hours of operation with the appearance of the alarm C3.**

Timer reset = Select FUNCTION SETTING,

- press OK,
- select FILTER CLEANING SET,
- press OK,
- select RECLOCK,
- press OK.

Filter extraction

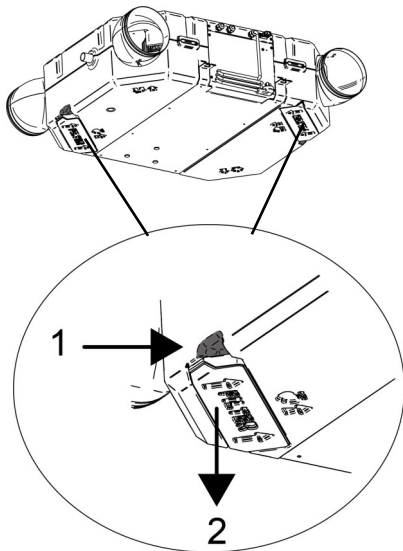

CLEANING THE AEREAUC/SANITISATION SYSTEM

Cleaning of the aerauc system is to be carried out by a specialised technician trained in aerauc hygiene air processing (in compliance with technical regulations and national/local regulations in force).

The aerauc system must be checked regularly to verify the state of conduits.

If there are any dirt deposits, contact a specialised technician and have it cleaned.

Cleaning is performed with the aid of suitable instruments (wheel brushes mounted on a flexible cable, vacuum cleaners, etc.), on supply and return conduits, distribution boxes, grilles and aeration inlets/outlets.

Conduits subject to dirt build-up are those that extract air from the room, while inlet conduits are less subject to clogging as the air is filtered; if an electrostatic filter is mounted, filtration improves and the air introduced into the room will be cleaner, thus resulting in cleaner conduits within Elfofresch-Evo

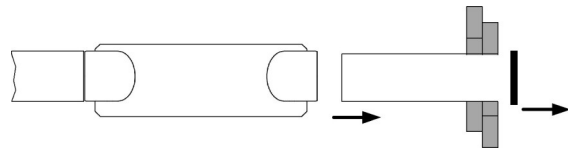

Disconnect the conduits from the unit

Remove the grille

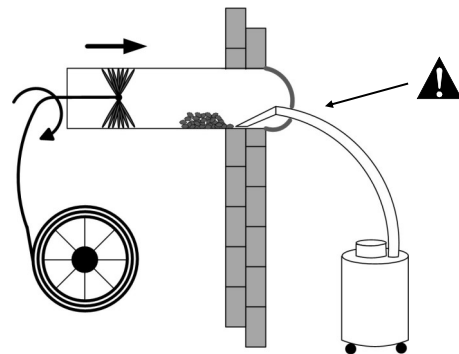

Clean the conduits

Use a suitable vacuum cleaner, cover the inlet

PERIODIC MAINTENANCE

Only qualified personnel can conduct work on the unit, as specified by current standards.



RECOMMENDED PERIODICAL CHECKS SHEET

Checks carried out on.....by.....company.....

√	intervention frequency (months)	3	6	12
<input type="checkbox"/>	unit structure control			●
<input type="checkbox"/>	panel fixing			●
<input type="checkbox"/>	fans fixing		●	
<input type="checkbox"/>	coil cleaning		●	
<input type="checkbox"/>	outflow test		●	
<input type="checkbox"/>	air filters cleaning/inspection	●		
<input type="checkbox"/>	electrostatic filter cleaning/inspection		●	
<input type="checkbox"/>	air flow rate measurement			●
<input type="checkbox"/>	channelling: anti-vibration devices and fastenings check			●
<input type="checkbox"/>	power supply cable isolation and fastening check			●
<input type="checkbox"/>	earth cable check			●
<input type="checkbox"/>	power remote controls state			●
<input type="checkbox"/>	clamps closure, cables isolation integrity			●
<input type="checkbox"/>	phases unbalancing and power supply voltage (vacuum and loaded)		●	
<input type="checkbox"/>	absorption of the individual electric loads		●	
<input type="checkbox"/>	compressors carter heaters test		●	
<input type="checkbox"/>	leaks control *			●
<input type="checkbox"/>	cooling circuit work parameters detection		●	
<input type="checkbox"/>	four-way valve exchange check		●	
<input type="checkbox"/>	protective equipment test: safety valves, pressure switches, thermostats, flow meters, etc.		●	
<input type="checkbox"/>	protective equipment test: setpoint, climatic compensations, power slicing, air flow rate variations		●	
<input type="checkbox"/>	control devices test: alarms signal, thermometers, probes, pressure gauges, etc.		●	

Notes/interventions recommended to Owner

* Refer to the local implemented standards; in synthesis and for merely indicative purposes, the regulation prescribes the following.
Companies and technicians carrying out installation, maintenance/repair interventions, leaks check and recovery must be CERTIFIED as foreseen by the local standards.
The leaks check must be carried out on a yearly basis



General

In this section the most common situations are signalled. As these cannot be controlled by the manufacturer these could be a source of risk situations for people or things.

Danger zone

This is an area in which only an authorised operator may work.

The danger zone is the area inside the unit which is accessible only with the deliberate removal of protections or parts thereof.

Handling

The handling operations, if implemented without all of the protection necessary and without due caution, may cause the fall or the tipping of the unit with the consequent damage, even serious, to persons, things or the unit itself.

Handle the unit following the instructions provided in the present manual regarding the packaging and in compliance with the local regulations in force.

Should the gas refrigerant leak please refer to the refrigerant "Safety sheet".

Installation

An incorrect installation of the unit could cause water leaks, condensate accumulation, leaking of the refrigerant, electric shock, bad functioning or damage to the unit itself.

Check that the installation has been implemented by qualified technical personnel only and that the instructions contained in the present manual and the local regulations in force have been adhered to.

The installation of the unit in a place where even infrequent leaks of inflammable gas and the accumulation of this gas in the area surrounding the area occur could cause explosions or fires.

Carefully check the positioning of the unit.

The installation of the unit in a place unsuited to support its weight and/or guarantee adequate anchorage may cause the fall or the tipping of the unit with the consequent damage to things, people or the unit itself.

Carefully check the positioning and the anchoring of the unit.

Easy access to the unit by children, unauthorised persons or animals may be the source of accidents, some serious.

Install the unit in areas which are only accessible to authorised person and/or provide protection against intrusion into the danger zone .

General risks

Smell of burning, smoke or other signals of serious anomalies may indicate a situation which could cause damage to people, things or the unit itself.

Electrically isolate the unit (yellow-red isolator).

Contact the authorised service centre to identify and resolve the problem at the source of the anomaly.

Accidental contact with exchange batteries, compressors, air delivery tubes or other components may cause injuries and/or burns.

Always wear suitable clothing including protective gloves to work inside the danger zone.

Maintenance and repair operations carried out by non-qualified personnel may cause damage to persons, things or the unit itself.

Always contact the qualified assistance centre.

Failing to close the unit panels or failure to check the correct tightening of all of the panelling fixing screws may cause damage to persons, things or the unit itself.

Periodically check that all of the panels are correctly closed and fixed.

If there is a fire the temperature of the refrigerant could reach values that increase the pressure to beyond the safety valve with the consequent possible projection of the refrigerant itself or explosion of the circuit parts that remain isolated by the closure of the tap.

Do not remain in the vicinity of the safety valve and never leave the refrigerating system taps closed.

Electric parts

An incomplete attachment line to the electric network or with incorrectly sized cables and/or unsuitable protective devices can cause electric shocks, intoxication, damage to the unit or fires.

Carry out all of the work on the electric system referring to the electric layout and the present manual ensuring the use of a system thereto dedicated.

An incorrect fixing of the electric components cover may favour the entry of dust, water etc inside and may consequently can electric shocks, damage to the unit or fires.

Always fix the unit cover properly.

When the metallic mass of the unit is under voltage and is not correctly connected to the earthing system it may be as source of electric shock and electrocution.

Always pay particular attention to the implementation of the earthing system connections.

Contact with parts under voltage accessible inside the unit after the removal of the guards can cause electric shocks, burns and electrocution.

Open and padlock the general isolator prior to removing the guards and signal work in progress with the appropriate shield.

Contact with parts that could be under voltage due to the start up of the unit may cause electric shocks, burns and electrocution.

When voltage is necessary for the circuit open the isolator on the attachment line of the unit itself, padlock it and display the appropriate warning shield.

Moving parts

Contact with the transmissions or with the fan aspiration can cause injuries.

Prior to entering the inside of the unit open the isolator situated on the connection line of the unit itself, padlock and display the suitable sign.

Contact with the fans can cause injuries.

Prior to removing the protective grill or the fans, open the isolator on the attachment line of the unit itself, padlock it and display the appropriate warning sign.

Refrigerant

The intervention of the safety valve and the consequent expulsion of the gas refrigerant may cause injuries and intoxication. Always wear suitable clothing including protective gloves and eyeglasses for operations inside the danger zone.

Should the gas refrigerant leak please refer to the refrigerant "Safety sheet".

Contact between open flames or heat sources with the refrigerant or the heating of the gas circuit under pressure (e.g. during welding operations) may cause explosions or fires.

Do not place any heat source inside the danger zone.

The maintenance or repair interventions which include welding must be carried out with the system off.

Hydraulic parts

Defects in tubing, the attachments or the cut-off parts may cause a leak or water projection with the consequent damages to people, things or short-circuit the unit.

DISCONNECTION

Only authorised personnel must disconnect the unit.

- Avoid leak or spills into the served area.
- Before disconnecting the unit, the following must be recovered, if present:
 - refrigerant gas
 - Anti-freeze solutions in the hydraulic circuits
- When awaiting dismantling and disposal, the unit can also be stored outdoors, as bad weather and rapid changes in temperature will not cause damage to the environment, if the unit's electric, cooling and hydraulic circuits are integral and closed.

DISMANTLING AND DISPOSAL

THE UNIT MUST ALWAYS BE SENT TO AUTHORISED CENTRES FOR DISMANTLING AND DISPOSAL.

When dismantling the unit, the fan, the motor and the coil, if operating, may be recovered by the specialist centres for reuse.

All the materials must be recovered or disposed of in compliance with the corresponding national standards in force.

For further information on the decommissioning of the unit, contact the manufacturer .

was likely to have been by both a private household and users of other than private households, it will be classed as private household WEEE;

Professional WEEE: all WEEE which comes from users other than private households.

This equipment may contain:

refrigerant gas, the entire contents of which must be recovered in suitable containers by specialised personnel with the necessary qualifications;

- lubrication oil contained in compressors and in the cooling circuit to be collected;
- mixtures with antifreeze in the water circuit, the contents of which are to be collected;
- mechanical and electrical parts to be separated and disposed of as authorised.

When machine components to be replaced for maintenance purposes are removed or when the entire unit reaches the end of its life and needs to be removed from the installation, waste should be separated by its nature and disposed of by authorised personnel at existing collection centres.



RAEE DIRECTIVE

The manufacturer is registered on the EEE National Register, in compliance with implementation of Directive 2012/19/EU and relevant national regulations on waste electrical and electronic equipment.

This Directive requires electrical and electronic equipment to be disposed of properly.

Equipment bearing the crossed-out wheeled bin mark must be disposed of separately at the end of its life cycle to prevent damage to human health and to the environment.

Electrical and electronic equipment must be disposed of together with all of its parts.

To dispose of "household" electrical and electronic equipment, the manufacturer recommends you contact an authorised dealer or an authorised ecological area.

"Professional" electrical and electronic equipment must be disposed of by authorised personnel through established waste disposal authorities around the country.

In this regard, here is the definition of household WEEE and professional WEEE:

WEEE from private households: WEEE originating from private households and WEEE which comes from commercial, industrial, institutional and other sources which, because of its nature and quantity, is similar to that from private households. Subject to the nature and quantity, where the waste from EEE

DIMENSIONS

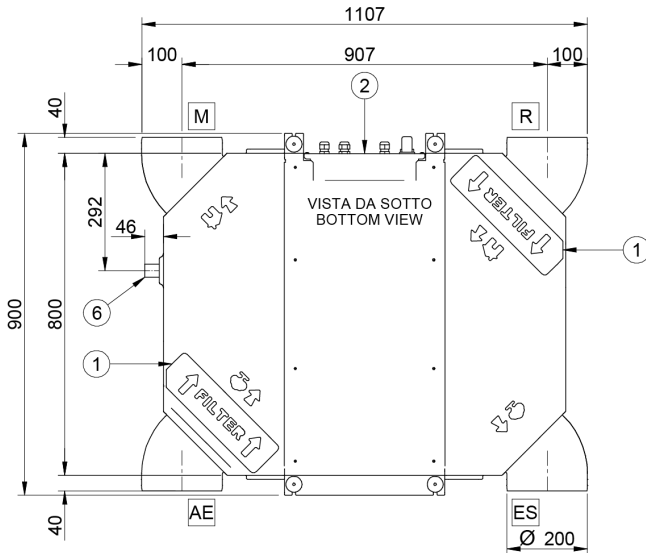
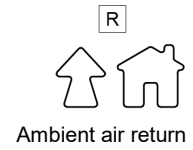
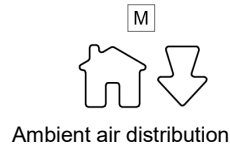
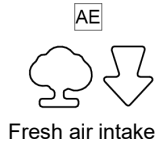

1	Removable panel for bottom access to the air filter
2	Electrical panel
3	Power input
4	keyboard connection
5	Auxiliary connection
6	Condensate drain connection
W1-W2	Hanging brackets
W3-W4	Hanging brackets
AE	Fresh air intake
ES	Air exhaust
M	Ambient air distribution
R	Ambient air return

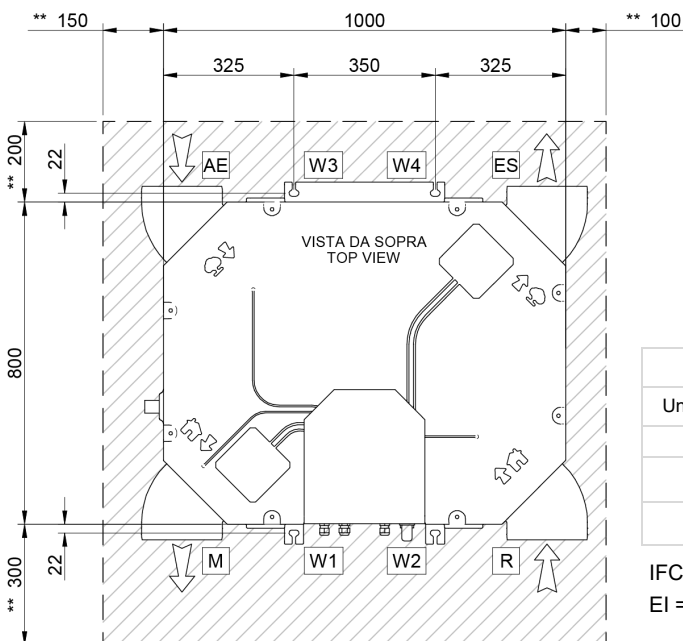
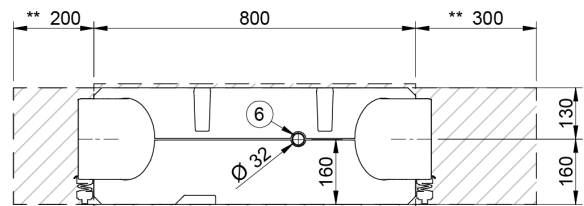
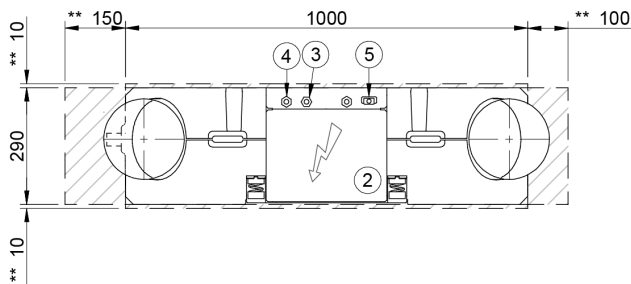

** MINIMUM SERVICE CLEARANCE

Unit configuration	Weicht distribution	
	Shipping weight	Operating weight
	kg	kg
IFC	73	44
EI	89	60

IFC = false-ceiling installation
EI = in-view installation

GENERAL TECHNICAL DATA
CPAN-YIN SIZE 2

Supply airflow	l/s	35	42	58	75	89
Supply airflow	m ³ /h	125	150	210	270	320
A7						
Heating capacity	kW	1,42	1,55	1,86	2,05*	2,49
Total power input	kW	0,46	0,42	0,45	0,42	0,54
COP (EN 14511:2018)	-	3,09	3,69	4,13	4,93	4,61
A-5						
Heating capacity	kW	1,97	2,10	2,21	2,37	2,45
Total power input	kW	0,40	0,52	0,47	0,37	0,32
COP (EN 14511:2018)	-	4,93	4,04	4,70	6,50	7,66
A30						
Cooling capacity	kW	0,92	1,38	1,47	1,72	2,07
Total power input	kW	0,36	0,52	0,48	0,54	0,81
COP (EN 14511:2018)	-	2,56	2,65	3,06	3,21	2,56
A35						
Cooling capacity	kW	1,57	1,64	1,73	1,92	2,23
Total power input	kW	0,36	0,52	0,53	0,55	0,81
EER (EN 14511:2018)	-	4,34	3,15	3,26	3,50	2,77
Rated static pressure supply fan	Pa	50	50	50	50	50
Max. static pressure supply fan	Pa	120	120	120	120	120
Standard power supply	V	220-240/~ /50	220-240/~ /50	220-240/~ /50	220-240/~ /50	220-240/~ /50
Min. entering air temperature (D.B.)	(2) °C	-15	-15	-15	-15	-15
Sound pressure level	(1) dB(A)	34	35	37	41	45

* Nominal heating capacity

All the data provided meets standard EN 14511:2018 and refers to an available head of 50 Pa.

A7 Ambient temperature 7°C D.B./ 6°C W.B., Extracted air temperature 20°C D.B./ 15°C W.B.

A-5 Ambient temperature -5°C D.B./ -5,4°C W.B., Extracted air temperature 20°C D.B./ 15°C W.B.

A30 Ambient temperature 30°C D.B./ 22°C W.B., Extracted air temperature 27°C D.B./ 19°C W.B.

A35 Ambient temperature 35°C D.B./ 24°C W.B., Extracted air temperature 27°C D.B./ 19°C W.B.

1. Available static pressure with clean air filter

2. The sound levels refer to units in nominal test conditions, and refers to an available head of 50 Pa.

In accordance with the UNI-EN ISO 3744 regulation, the average sound pressure level refers to a distance of 1 m from the outer surface of a ducted unit installed in the false-ceiling.

CONSTRUCTION
SIZE 2

Compressor			
Type of compressors	(1)	-	ROT
Refrigerant			R32
No. of compressors		Nr	1
Gradini capacità (ST)		%	20-100
Oil charge		[l]	0,017
Refrigerant charge		[kg]	0,3
Refrigerant circuits		[Nr]	1
Treatment Area Fans (Supply)			
Type of fans	(2)		CFG
No. of fans			1
Fan diameter		[mm]	140
Type of motor	(3)		EC
Airflow		[mc/h]	125-320
Treatment Area Fans (Return)			
Type of fans	(2)		CFG
No. of fans			1
Fan diameter		[mm]	140
Type of motor	(3)		EC
Airflow		[mc/h]	125-400
Connections			
Condensate drain	(4)	[mm]	32
Electirical data			
F.L.A. Compressor 1	(5)	[A]	4,1
F.L.A. Single supply fan	(5)	[A]	0,62
F.L.A. Single exhaust air fan	(5)	[A]	0,62
F.L.A. Total	(5)	[A]	5,45
F.L.I. Compressor 1	(5)	[kW]	0,91
F.L.I. Single supply fan	(5)	[kW]	0,08
F.L.I. Single exhaust air fan	(5)	[kW]	0,08
F.L.I. Total	(5)	[kW]	1,08

1. ROT = rotary compressor
2. CFG = centrifuge fan
3. EC = EC Electronic switching motor
4. Condensate drain connection, external diameter
5. Data refer to standard units. Power supply 220-240V/~50Hz Voltage variation: max +/-6%



SOUND LEVELS - COOLING

[m ³ /h]	SOUND POWER LEVEL (DB)								Sound power level	Sound pressure
	63	125	250	500	1000	2000	4000	8000	dB(A)	dB(A)
125	27	25	37	40	34	30	29	30	34	47
150	28	26	38	40	35	31	30	31	35	48
210	31	32	38	41	42	36	30	26	37	50
270	32	34	41	42	45	41	37	27	41	54
320	36	38	45	46	49	45	41	31	45	58

Sound levels are referred to unit at nominal condition when installed in false ceiling and connected to ducts. External static pressure 50 Pa.

Cooling: Ambient temperature 35°C D.B./ 24°C W.B., Extracted air temperature 27°C D.B./ 19°C W.B.

Average sound pressure level, according to UNIEN ISO 3744, is measured at 1m distance from the unit surface, when installed in false ceiling and connected to ducts.

Power measurements are according to UNI EN ISO 9614-2, with unit connected to ducts and installed in the vicinity of a reflecting surface, allowing 2 dB (A) tolerance.

Noise values referred to:

- standard operation with air flow rate from 320mc/h to 125mc/h
- SILET mode with air flow rate from 210mc/h to 125mc/h
- SUPER SILET mode with air flow rate 125mc/h

SILENT and SUPER SILENT modes (setting from remote control) operate a reduction of compressor and fan speed, reducing their noise emission. Please note that noise levels may differ significantly if the unit is installed in different conditions (ex: with surrounding obstacles, walls or similar).

SOUND LEVELS - HEATING

[m ³ /h]	SOUND POWER LEVEL (DB)								Sound power level	Sound pressure
	63	125	250	500	1000	2000	4000	8000	dB(A)	dB(A)
125	24	23	33	40	34	27	24	31	33	46
150	25	24	34	40	35	28	25	32	34	47
210	30	32	37	40	38	33	27	26	36	49
270	30	32	39	40	43	39	34	33	39	52
320	34	36	43	43	47	43	38	37	43	56

Sound levels are referred to unit at nominal condition when installed in false ceiling and connected to ducts. External static pressure 50 Pa.

Heating: Ambient temperature 7°C D.B./ 6°C W.B., Extracted air temperature 20°C D.B./ 13.7°C W.B.

Average sound pressure level, according to UNIEN ISO 3744, is measured at 1m distance from the unit surface, when installed in false ceiling and connected to ducts.

Power measurements are according to UNI EN ISO 9614-2, with unit connected to ducts and installed in the vicinity of a reflecting surface, allowing 2 dB (A) tolerance.

Noise values referred to:

- standard operation with air flow rate from 320mc/h to 125mc/h
- SILET mode with air flow rate from 210mc/h to 125mc/h
- SUPER SILET mode with air flow rate 125mc/h

SILENT and SUPER SILENT modes (setting from remote control) operate a reduction of compressor and fan speed, reducing their noise emission. Please note that noise levels may differ significantly if the unit is installed in different conditions (ex: with surrounding obstacles, walls or similar).

OPERATING RANGE

Heating

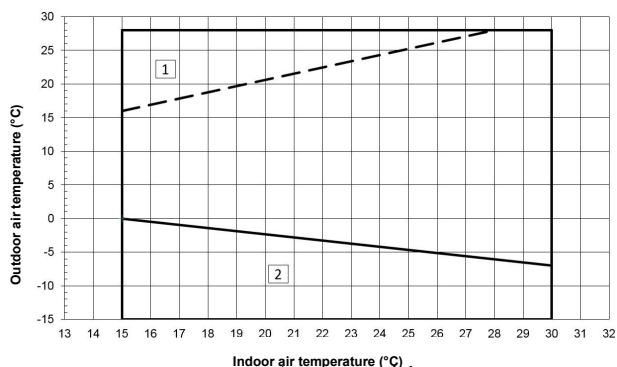

The limits are meant as a guide. Please note that they have been calculated by considering:

- nominal airflow
- exchangers and clean filters
- straightforward unit installation and correct use and maintenance of the unit itself.
- operating range with **outdoor relative humidity > 50%**

1. Zone of possible operation in FREE HEATING
2. Operating range with possible supply air flow modulation; defrosting may occur

The unit can modulate the air flow rate in order to keep operating in the operating range

Cooling

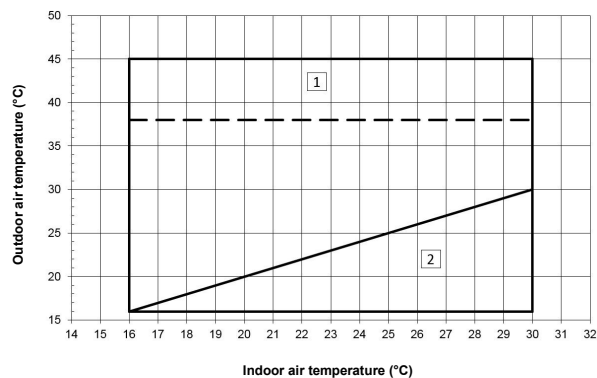

The limits are meant as a guide. Please note that they have been calculated by considering:

- nominal airflow
- exchangers and clean filters
- straightforward unit installation and correct use and maintenance of the unit itself.

1. Operating range with outdoor relative humidity < 40%
2. Zone of possible operation in FREE-COOLING

The unit can modulate the air flow rate in order to keep operating in the operating range

ELFOAir

1 DAIR50X - DAIR80X
AIRJET 50/l - 80/l supply diffuser - white frame and black inside



9 TFT90X
DN90 round flexible tube (Int. diam. 78mm) in a 20m. coil without insulation



40 REGPX
Automatic flow controller DN80 - L75



39 GPRX
Grill for recirculation air return plenum 325x175 mm white



2 GAIR50X - GAIR80X
Intake grille + extractable filter AIRJET 50/A - 80/A - white frame and black inside



10 IT90X
Insulation in a 20mt. coil for DN90 round flexible tube



11 CBT90X
Connector to distribution box for DN90 round tube



3 PAIR50X - PAIR80X
Suction/supply plenum with AIRJET 50 - 80 control damper - rear connection

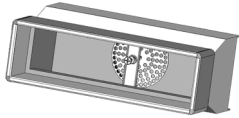

12 GIUTX
Connecting joint for DN90 round tube



4 GINOX - GIVEX
Suction/supply rectangular grill 350x130mm stainless or white



13 CT90X
Printed curve of 90-degree angle for DN90 round tube



5 FREX
Filter for rectangular grilles 350x130mm (5 pcs.)



14 A90DTX
90-degree adaptor, double DN90 round tube for DN125 valve + cap



6 VIEX
Extraction/intake valve in ABS DN125 without air filter



15 TACTX
Cap for DN90 round tube (5 pcs.)



7 FT125X
Filter for DN125 valve (5 pcs.)



16 ANFTX
DN90 seal O-Ring (10 pcs.)



8 GQIEX
Extraction/intake squared grill of DN125 joint with air filter

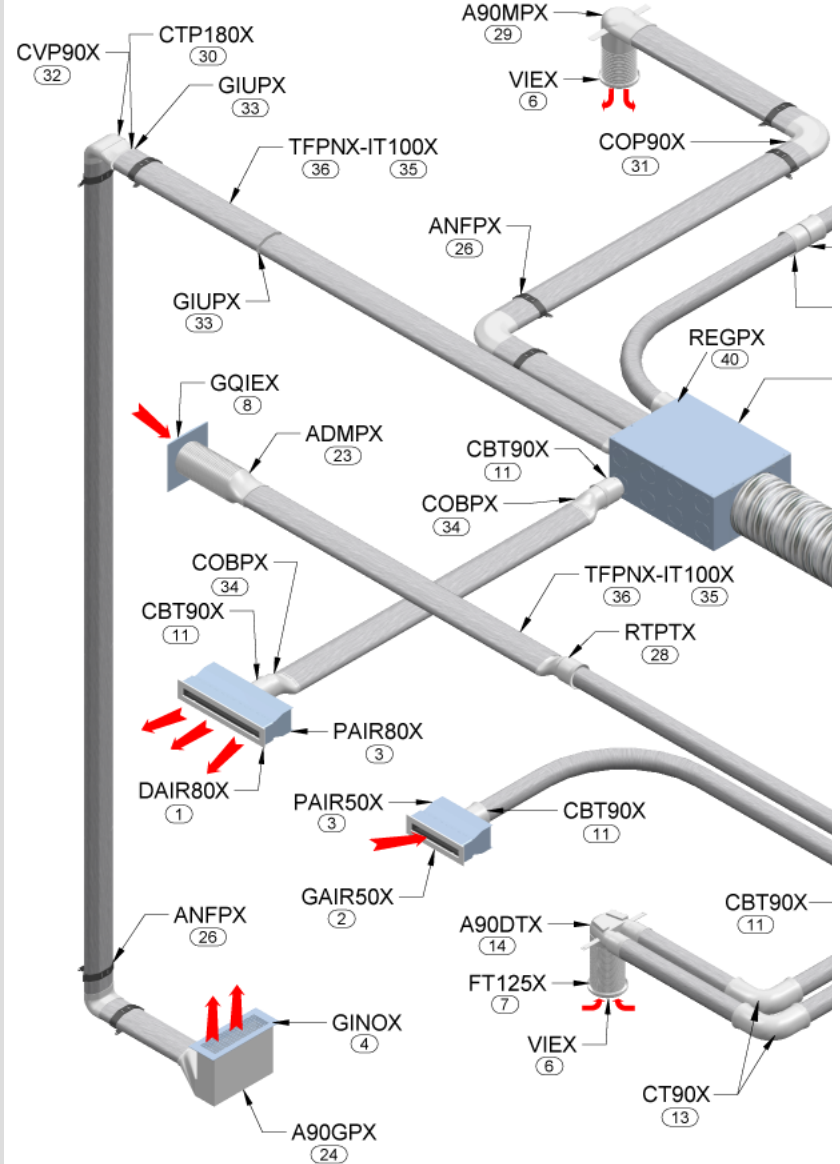

17 TFIS150X - TFIS200X - TFIS250X
DN150/200/250 soundproofing insulated flexible tube in a 10mt. coil



18 GR150X-GR200X- GR250X
Exhaust / return squared wall grid with circular coupling DN150/200/250



19 GF150X GF200X GF250X

38

BD14CX
14-output distribution box,
DN200 joint

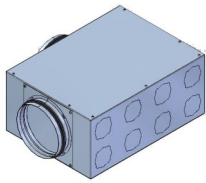

37

BD8CX
8-output distribution box,
DN150-200 joint

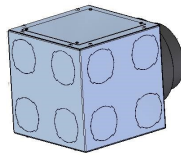

36

TFPNX
Flat flexible tube 132x52mm
in a 20m. coil without insulation



28

RTPTX
Round/flat tube connecting joint



35

IT100X
Insulation in a 20mt. coil
for flat flexible tube 132x52

27

REPPX
Flow controller for flat tube

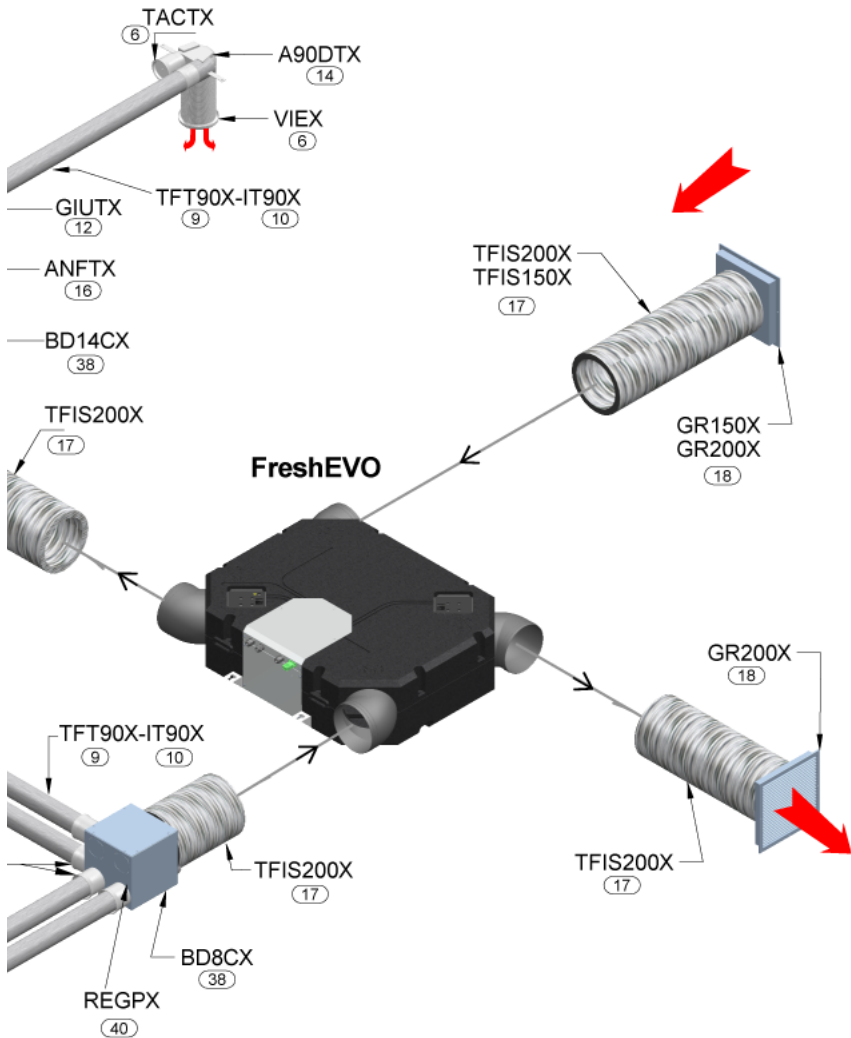

34

COBPX
DN90 connector joint
(CBT90X) --> flat tube

26

ANFPX
Fixing ring for flat tube (10 pcs.)

33

GIUPX
Seal and connecting joint
for flat tube (10 pcs.)

25

TACPX
Cap for flat tube (5 pcs.)

32

CVP90X
Vertical 90-degree curve
for flat tube

24

A90GPX
90-degree adaptor, single tube
for flat grill 350x130 mm

31

COP90X
Horizontal 90-degree curve
for flat tube

23

ADMPX
Straight adaptor, single flat tube
for DN125 valve

30

CTP180X
Joint for 180-degree
flat tube rotation

29

A90MPX
90-degree adaptor, single tube
for DN125 valve

22

A90DPX
90-degree adaptor, double flat
tube for DN125 valve

20

F/F DN150/200/250
joint



R2015X - R2520X
DN200-DN150 reducer
DN250-DN200 reducer



21

DY200X
DN200-DN200-DN200 Y-joint
DY250X
DN250-DN200-DN200 Y-joint



ELFOAir

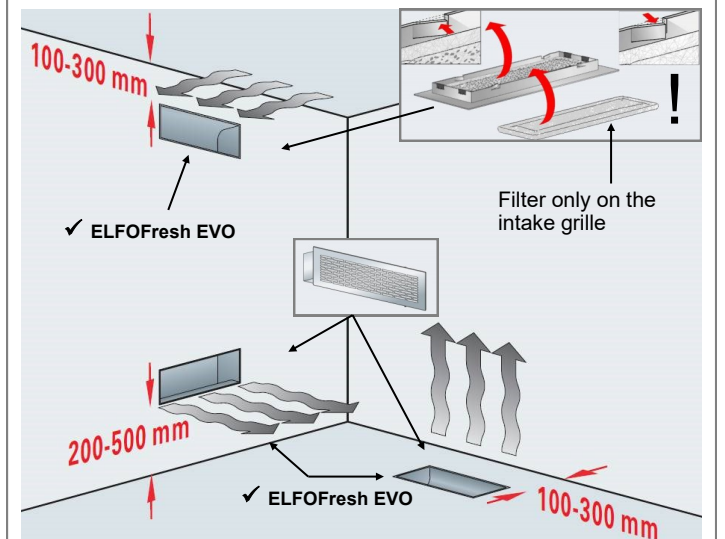
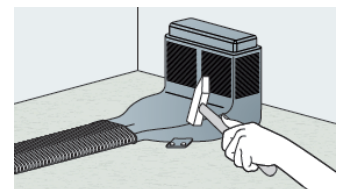
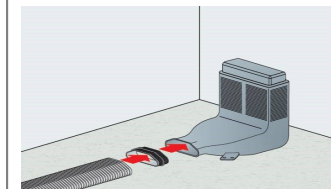
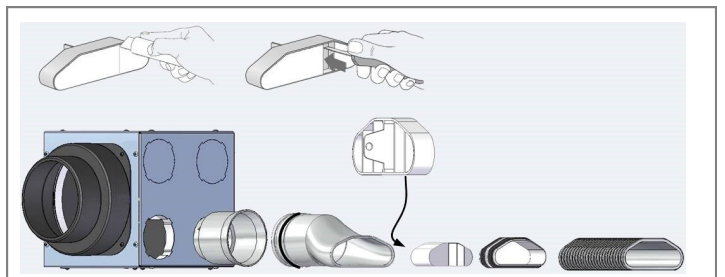
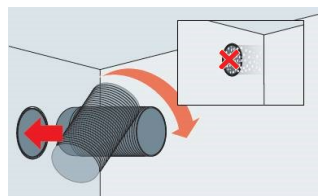
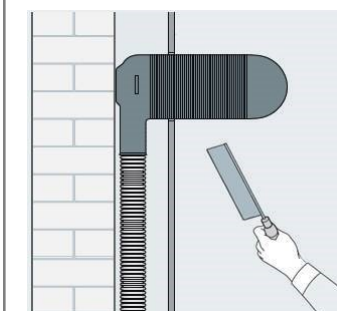
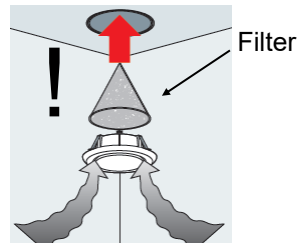
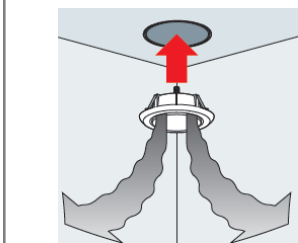
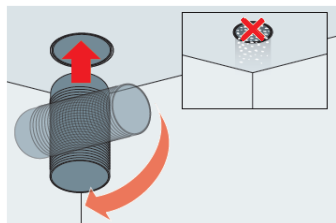
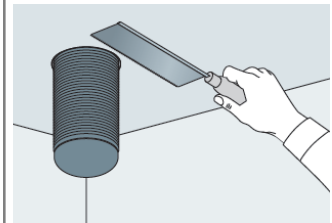
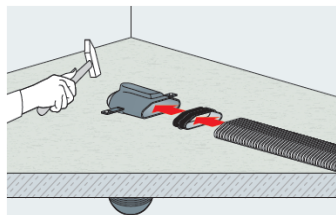
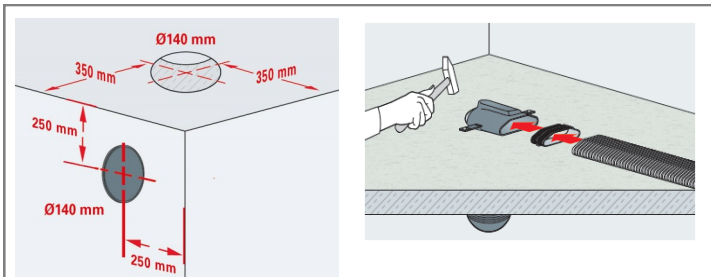
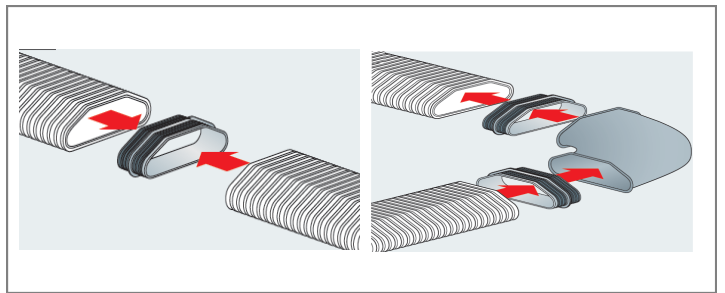
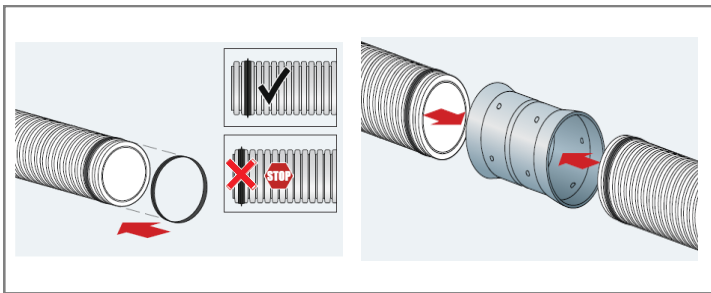
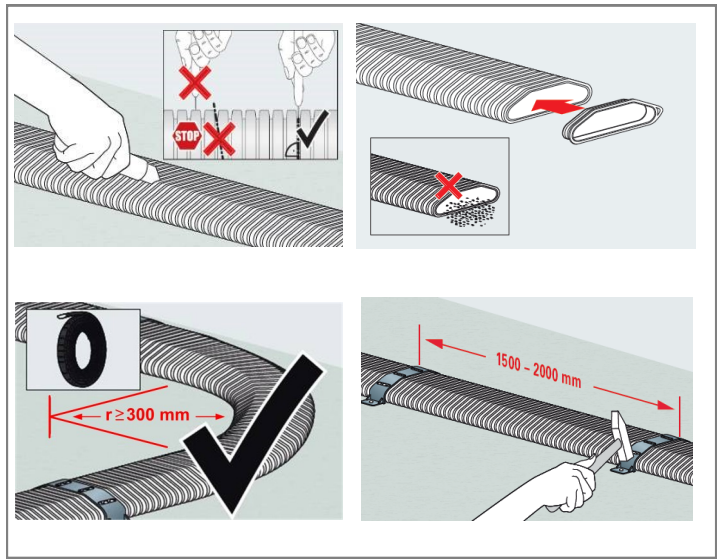
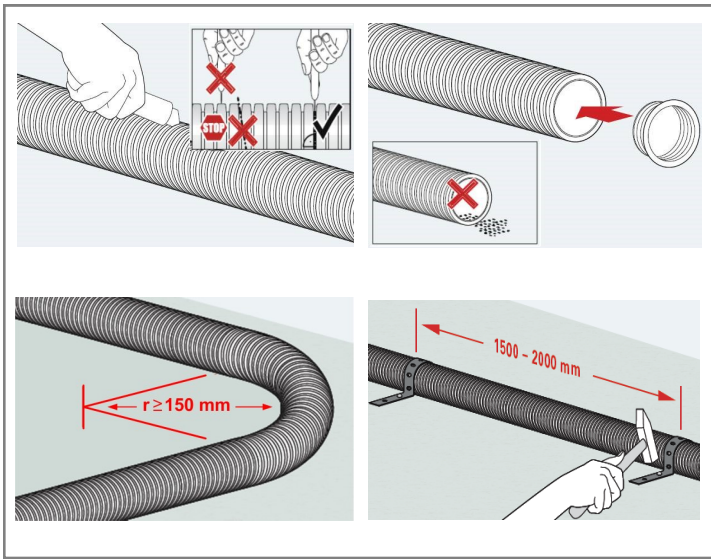

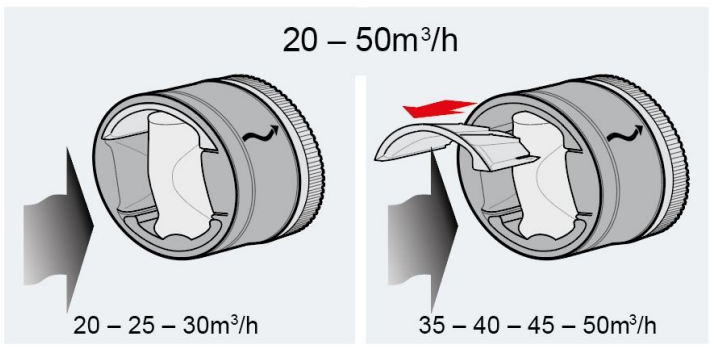
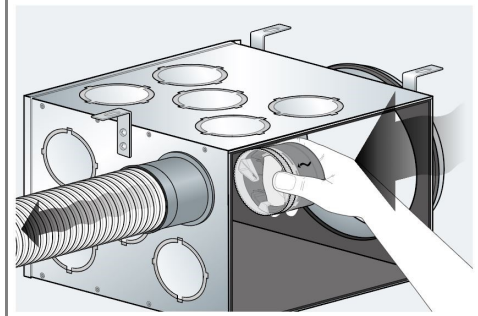
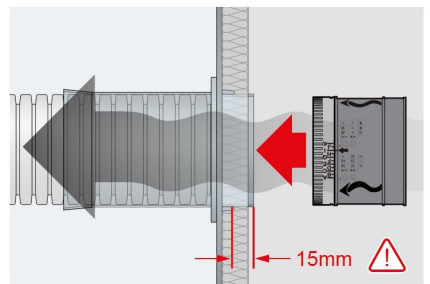
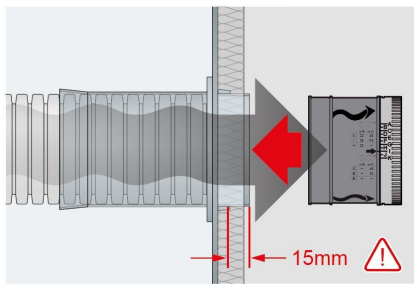
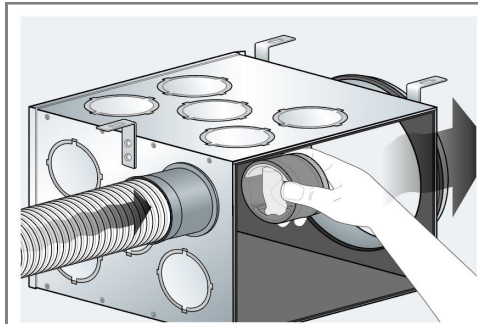
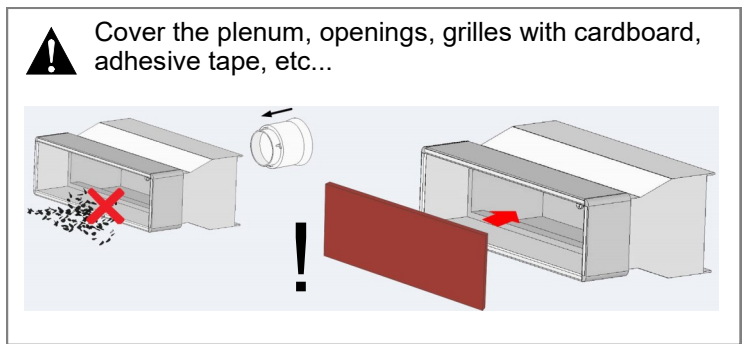
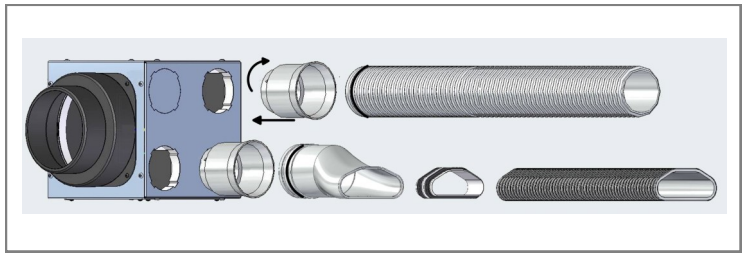
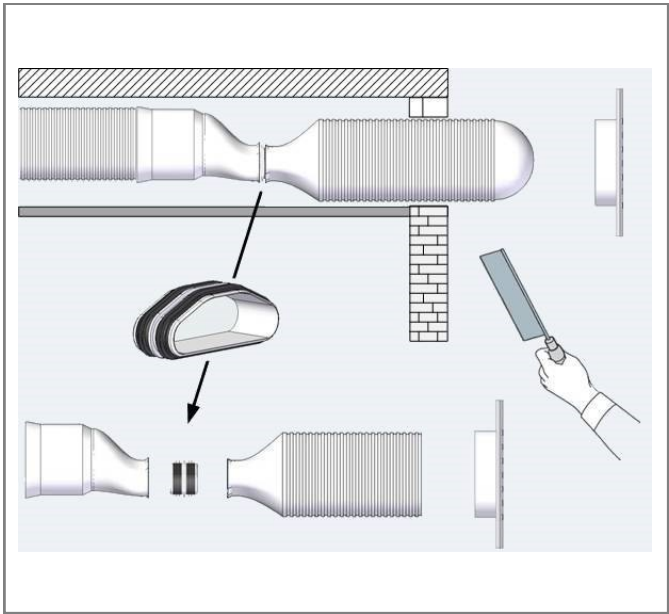
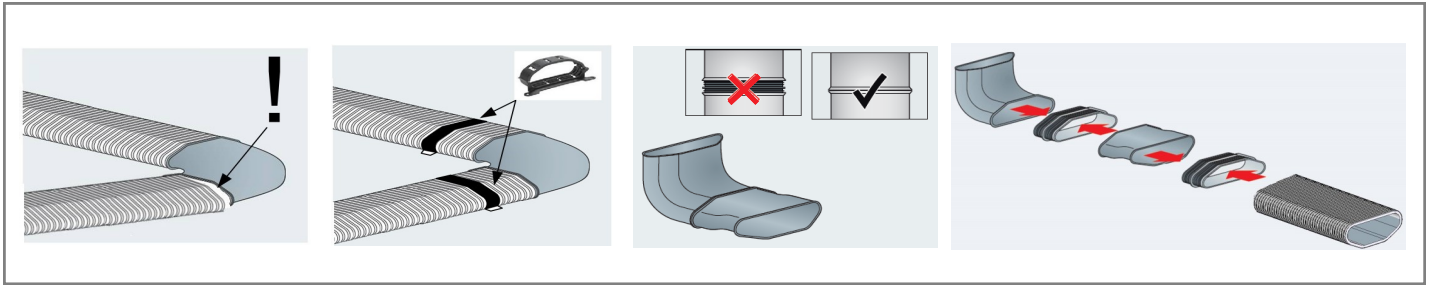

20 – 25 – 30m³/h

	m ³ /h	m ³ /h	
K	20	35	
I	25	40	
H	30	-	
	m ³ /h	m ³ /h	
G	-	45	
E	-	50	
B	-	-	

35 – 40 – 45 – 50m³/h

	m ³ /h	m ³ /h		
K	20	35		
I	25	40		
H	30	-		
	m ³ /h	m ³ /h		
G	-	45		
E	-	50		
B	-	-		

NOTE

FOR OVER 30 YEARS, WE HAVE BEEN OFFERING
SOLUTIONS TO ENSURE SUSTAINABLE COMFORT
AND THE WELL-BEING OF PEOPLE AND THE
ENVIRONMENT



sales and assistance

www.clivet.com

MideaGroup
humanizing technology



CLIVET S.p.A.

Via Camp Lonc 25, Z.I. Villapaiera
32032 Feltre (BL) - Italy
Tel. +39 0439 3131 - info@clivet.it

CLIVET GMBH

Hummelsbütteler Steindamm 84,
22851 Norderstedt, Germany
Tel. +49 40 325957-0 - info.de@clivet.com

Clivet Group UK LTD

Units F5 & F6 Railway Triangle,
Portsmouth, Hampshire PO6 1TG
Tel. +44 02392 381235 -
Enquiries@Clivetgroup.co.uk

CLIVET LLC

Office 508-511, Elektrozavodskaya st. 24,
Moscow, Russian Federation, 107023
Tel. +7495 6462009 - info.ru@clivet.com

CLIVET MIDEAST FZCO

Dubai Silicon Oasis (DSO) Headquarter Building,
Office EG-05, P.O Box-342009, Dubai, UAE
Tel. +9714 3208499 - info@clivet.ae

Clivet South East Europe

Jarušćica 9b
10000, Zagreb, Croatia
Tel. +385916065691 - info.see@clivet.com

Clivet Airconditioning Systems Pvt Ltd

Office No.501 & 502,5th Floor, Commercial -I,
Kohinoor City, Old Premier Compound, Off LBS
Marg, Kiroi Road, Kurla West, Mumbai
Maharashtra 400070, India
Tel. +91 22 30930200 - sales.india@clivet.com