



CSRN-iY

20.2-56.4

**MANUAL**  
FOR INSTALLATION,  
USE AND MAINTENANCE



M08000009--02 12-22024

**R32**

---

Dear Customer,

We congratulate you on choosing these product

Clivet has been working for years to offer systems able to assure the maximum comfort for a long time with highly-reliable, efficient, high-quality and safe solutions. The target of the company is to offer advanced systems, that assure the best comfort and reduce energy consumption as well as the installation and maintenance costs for the entire life-cycle of the system.

With this manual, we want to give you information that are useful for all phases: from reception, installation and use to disposal - so that such an advanced system can provide the best performances during installation and use.

Best regards and have a good read.

CLIVET Spa

The data contained in this manual is not binding and may be changed by the manufacturer without prior notice. Reproduction, even partial, is FORBIDDEN. © Clivet S.p.A. - Feltre (BL) - Italia

---

## INDEX

<b>Safety considerations</b>	<b>4</b>
<b>Information on refrigerant gas</b>	<b>7</b>
<b>Configurations</b>	<b>8</b>
<b>Reception</b>	<b>11</b>
<b>Selecting the installation site</b>	<b>13</b>
<b>Water connections</b>	<b>24</b>
<b>Aeraulic connections</b>	<b>27</b>
<b>Electrical connections</b>	<b>28</b>
<b>Start-up</b>	<b>36</b>
<b>Control</b>	<b>49</b>
<b>Modbus</b>	<b>63</b>
<b>Safety warnings for R32</b>	<b>69</b>
<b>Maintenance</b>	<b>72</b>
<b>Decommissioning</b>	<b>81</b>
<b>Residual risks</b>	<b>82</b>
<b>Technical information</b>	<b>84</b>

### Safety

Operate in compliance with safety regulations in force.

To carry out the operations use protection devices:

gloves, goggles, helmet, headphones, protective knee pads.

All operations must be carried out by personnel trained on possible risks of a general nature, electrical and deriving from operating with equipment under pressure.

Only qualified personnel can operate on the unit, as required by the regulation in force.

### Manual

The manual provides correct unit installation, use and maintenance.

It is advisable to read it carefully so you will save time during operations.

Follow the written indications so you will not cause damages to things and injuries people.

### Risk situations

The unit has been designed and created to prevent injuries to people.

During designing it is not possible to plane and operate on all risk situation.

Read carefully "Residual risk" section where all situation which may cause damages to things and injuries to people are reported.

Installation, starting, maintenance and repair required specific knowledge; if they are carried out by inexperienced personnel, they may cause damages to things and injuries people.

### Intended use

Use the unit only:

- civil air-conditioning
- keep to the limits foreseen in the technical schedule and in this manual

The manufacturer accepts no responsibility if the equipment is used for any purpose other than the intended use.

### Installation

Outdoor installation

The positioning, hydraulic system, refrigerating, electrics and the ducting of the air must be determined by the system designer in accordance with local regulations in force.

Follow local safety regulations.

Verify that the electrical line characteristics are in compliance with data quotes on the unit serial number label.

### Maintenance

Plan periodic inspection and maintenance in order to avoid or reduce repairing costs.

Turn the unit off before any operation.



### Before any work read:

⇒ *Chapter. SAFETY WARNINGS FOR OPERATIONS ON UNITS CONTAINING R32*



### Pay particular attention to:

⇒ warnings / prohibitions / danger indicating particularly important operations or information, operations that cannot be done, which compromise the functionality of the unit or which may cause damage to things or persons.

### Outdoor installation

### Modification

All unit modifications will end the warranty coverage and the manufacturer responsibility.

### Breakdown/Malfunction

Disable the unit immediately in case of breakdown or malfunction.

Contact a certified service agent.

Use original spares parts only.

Using the unit in case of breakdown or malfunction:

- voids the warranty
- it may compromise the safety of the unit
- it may increase time and repair costs

### User training

The installer has to train the user on:

- start-up/shutdown
- set points change
- standby mode
- maintenance
- what to do / what not to do in case of breakdown.

### Data update

Continual product improvements may imply manual data changes.

Visit manufacturer web site for updated data.

### Indications for the User

Keep this manual with the wiring diagram in an accessible place for the operator.

Note the unit data label so you can provide them to the assistance centre in case of intervention (see "Unit identification" section).

Provide a unit notebook that allows any interventions carried out on the unit to be noted and tracked making it easier to suitably note the various interventions and aids the search for any breakdowns.

### In case of breakdown or malfunction

- Immediately deactivate the unit
- Contact a service centre authorized by the manufacturer

### The installer must train the user, particularly on:

- Start-up/shutdown
- Set points change
- Standby mode
- Maintenance
- What to do / what not to do in case of breakdown

### Unit identification

The serial number label is positioned on the unit and allows to identify all the unit features.

The matriculation plate shows the indications foreseen by the standards, in particular:

- unit type
- serial number (12 characters)
- year of manufacture
- wiring diagram number
- electrical data
- type of refrigerant
- refrigerant charge
- manufacturer logo and address

The matriculation plate must never be removed.

It contains fluorinated greenhouse gases.

### Serial number

It identifies uniquely each unit.

Must be quoted when ordering spare parts.

### Assistance request

Note data from the serial number label and write them in the chart on side, so you will find them easily when needed.

Series
Size
Serial number
Year of manufacture
Number of electrical wiring diagram

This product contains fluorinated greenhouse gases covered by the Kyoto protocol.

Do not discharge gas into air.

Refrigerant type: R32

The refrigerant quantity is indicated on the unit plate

Size	Configuration	Refrigerant (Kg)	Equivalent CO <sup>2</sup> tons
20.2	CAK / CBK / CBK-G	8 + 8	10,8
	CCK-REVO	9,5 + 9,5	12,8
28.2	CAK / CBK / CBK-G	9 + 9	12,2
	CCK-REVO	11 + 11	14,9
40.4	CAK / CBK / CBK-G	19 + 19	25,7
	CCK-REVO	20 + 20	27
56.4	CAK / CBK / CBK-G	21 + 21	28,4
	CCK-REVO	22 + 22	29,7

### Physical characteristics of the R32 refrigerant

Safety class (ISO 817)	A2L	
GWP	675	
LFL Low flammability limit	0.307	kg/m <sup>3</sup> @T>30°C
BV Burning velocity	6,7	cm/s
Boiling point	-52	°C
GWP	675	100 yr ITH
GWP	677	AR5 - 100 yr ITH
Self-ignition temperature	648	°C

## CONFIGURATIONS

### CAK configuration

Single fan section for full recirculation

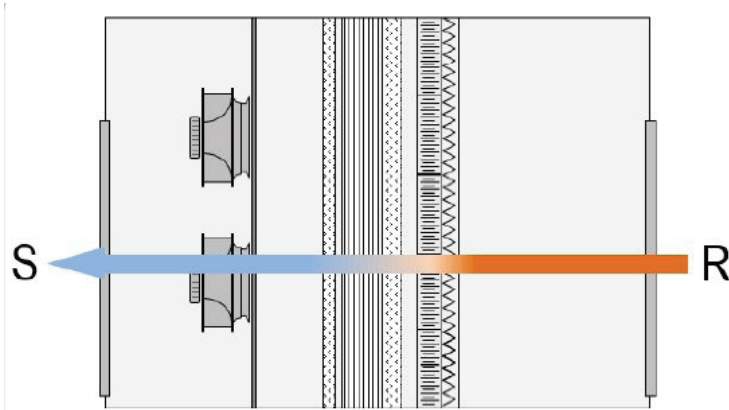

R. Return air  
S. Supply air

### CBK configuration

Single fan section for recirculation and fresh air

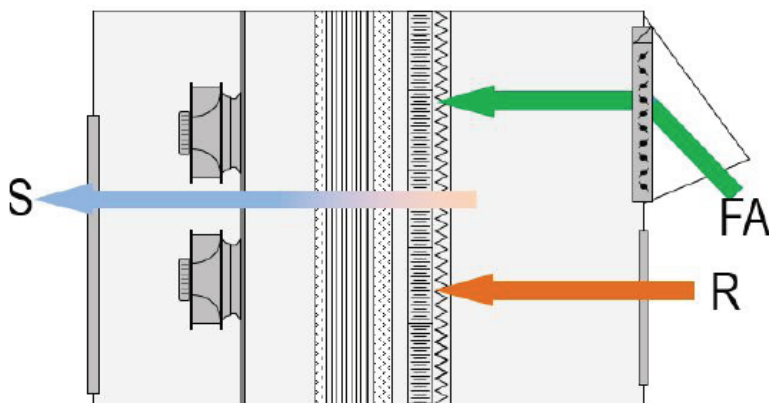

R. Return air  
S. Supply air  
FA. Fresh air



### CBK-G configuration

Single fan section for recirculation, fresh and exhaust air

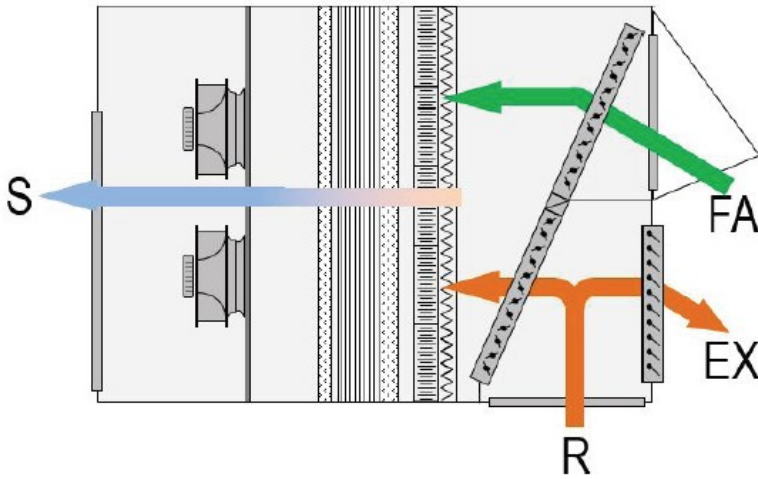

- R. Return air
- S. Supply air
- FA. Fresh air
- EX. Exhaust air

### CCK-REVO configuration

Double fan section for recirculation, fresh and exhaust air

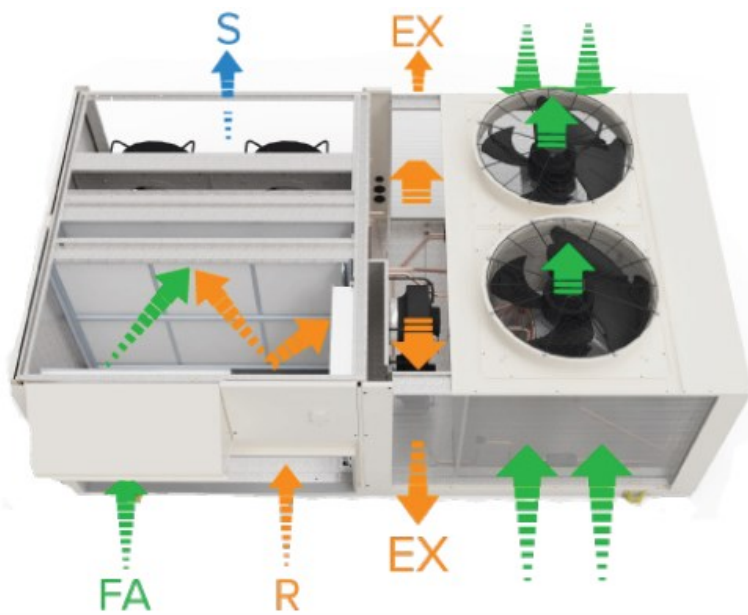

- R. Return air
- S. Supply air
- FA. Fresh air
- EX. Exhaust air

Supply and return configuration

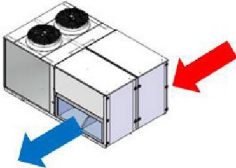
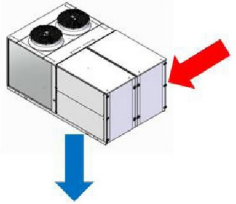
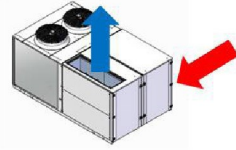
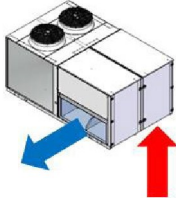
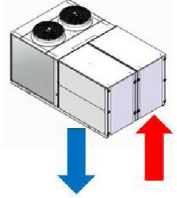
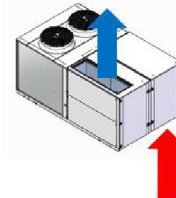
<b>M0 - R0</b> Standard unit	<b>M3 - R0</b> Option	<b>M5 - R0</b> Option
		
<b>M0 - R3</b> Option	<b>M3 - R3</b> Option	<b>M5 - R3</b> Option
		

Filters nomenclature according to EN ISO 16890

1° filtering stage - standard	G4	ISO 16890 Coarse 60%
2° filtering stage - option	F7	ISO 16890 ePM1 55%
2° filtering stage - option	F9	ISO 16890 ePM1 80%
2° filtering stage - option	iFD (electronic filters)	ISO 16890 ePM1 90%

### Safety

Operate in compliance with safety regulations in force.

For detailed information (dimensions, weight, technical characteristics etc.) please refer to the TECHNICAL INFORMATION section.

Use single protection devices: gloves, glasses etc.

### Reception

You have to check before accepting the delivery:

- That the unit hasn't been damaged during transport
- That the materials delivered correspond with that indicated on the transport document comparing the data with the identification label positioned on the packaging.

In case of damage or anomaly:

- write down on the transport document the damage you found and quote this sentence: "Conditional acceptance clear evidence of deficiencies/damages during transport"
- contact by fax and registered mail with advice of receipt to supplier and the carrier.

#### NOTE

⇒ Any disputes must be made within 8 days from the date of the delivery. Complaints after this period are invalid .

### Storage

Respect the indications on the outside of the pack.

In particular:

⇒ *minimum ambient temperature -10°C*  
*(possible components damages)*

⇒ *maximum ambient temperature +50°C*  
*(possible safety valve opening)*

⇒ *maximum relative humidity 95%*  
*(possible damages to electrical components)*

#### NOTE

⇒ *The unit may not be tilted more than 15° during transport.*

#### NOTE

### Removal of packaging

Be careful not to damage the unit.

Recycle and dispose of the packaging material in compliance with local regulations.

## Handling

### Caution

- ⇒ Check that all handling equipment complies with local safety regulations (cran, forklifts, ropes, hooks, etc.).
- ⇒ Provide personnel with personal protective equipment suitable for the situation, such as helmet, gloves, accident-prevention shoes, etc.
- ⇒ Observe all safety procedures in order to guarantee the safety of the personnel present and the of material.

- A. Verify unit weight and handling equipment lifting capacity.
- B. Identify critical points during handling (disconnected routes, flights, steps, doors).
- C. Suitably protect the unit to prevent damage.
- D. Lifting with balance (A)
- E. Lifting with spacer bar (B)
- F. Align the barycenter to the lifting point
  - Gradually bring the lifting belts under tension, making sure they are positioned correctly.
  - Before starting the handling, make sure that the unit is stable.

A



B

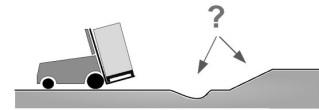

C

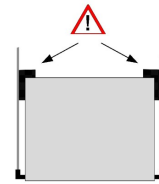

D

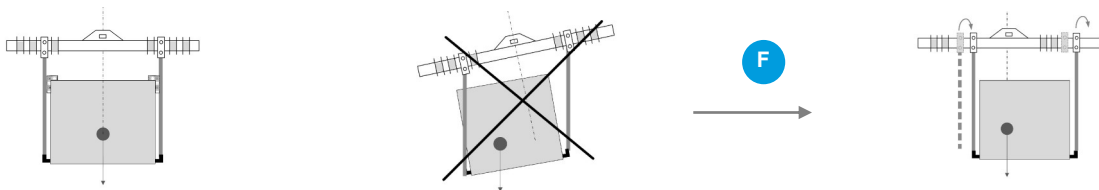

E

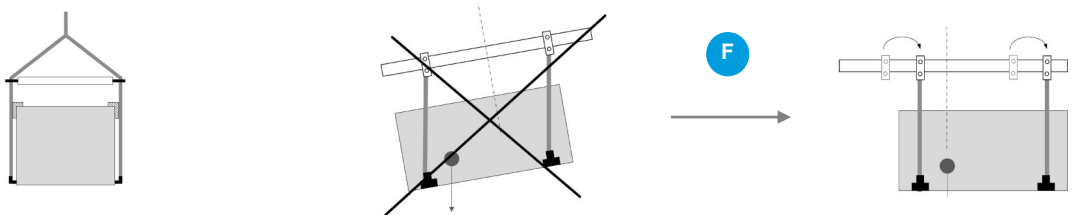

### Positioning

⇒ Installation must be in accordance with local regulations. If they do not exist, follow EN378.

During positioning consider these elements:

- customer approval
- unit weight and bearing point capacity
- safe accessible position
- functional spaces
- spaces for the air intake/exhaust
- electrical connections
- max. distance allowed by the electrical connections
- water connections

### Functional spaces

Functional spaces are designed to:

- guarantee good unit operation
- carry out maintenance operations
- protect authorized operators and exposed people

⇒ Respect all functional spaces indicated in the TECHNICAL INFORMATION section.

### Positioning

Units are designed to be installed:

- EXTERNAL
- in fixed positions

⇒ Put the unit in a position where any leaking gas cannot enter buildings or stagnate in closed areas. In the latter case, observe the rules for machinery rooms (ventilation, leak detection, etc.).

Installation standards:

- install the unit raised from the ground
- bearing points aligned and leveled
- discharged condensation water must not cause harm/danger to people and property
- the accumulation of snow must not cause clogging of the coils
- avoid installations in places subject to flooding

Limit vibration transmission:

- use anti-vibration devices or neoprene strips on the unit support points
- install flexible joints on the hydraulic and aeraulic connections

The unit must not support the weight of channels, pipes, etc.

Protect the unit with suitable fence in order to avoid access to unauthorised personnel (children, vandals, etc.)

A correct circulation of the air is mandatory to guarantee the good unit operating..

The unit must be level.

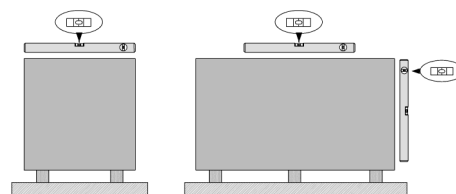

Do not go up to the surface  
Not placing heavy objects

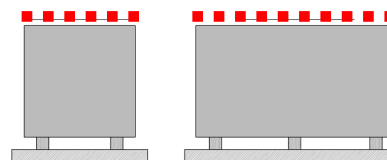

Concrete floor

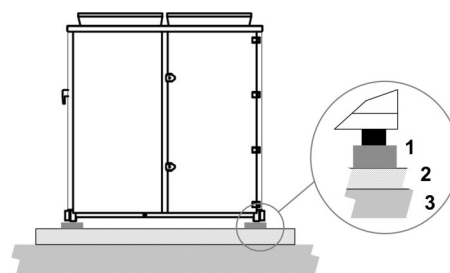

- 1 2 cm thick neoprene strips
- 2 concrete floor
- 3 floor

Steel structure

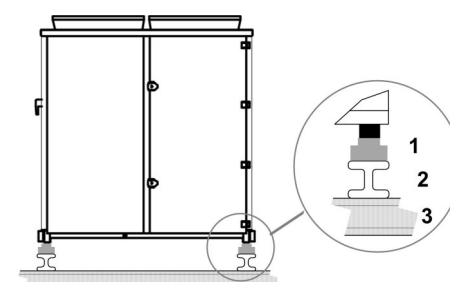

- 1 anti-vibration devices
- 2 steel structure
- 3 steel structure

Avoid therefore:

- obstacles to the airflow
- exchange difficulties
- leaves or other foreign bodies that can obstruct the exchange batteries
- winds that hinder or favour the airflow
- heat or pollution sources close to the unit (chimneys, extractors etc)
- stratification (cold air that stagnates at the bottom)
- recirculation (expelled air that is sucked in again)
- positioning below the level of the threshold, close to very high walls, attics or in angles that could give rise to stratification or recirculation phenomenons.

Ignoring the previous indications could:

- energy efficiency decrease
- alarm lockout due to HIGH PRESSURE (in summer) or LOW PRESSURE (in winter)

### CBK, CBK-G, CCK-REVO configurations only

Avoid the accumulations of snow and ice in front of the exhaust air outlet.

### Only if FIFD filter is present

The most common contaminants for which the filter is designed, are:

- air pollution by PM10, PM 2,5 and PM1

Contaminants that can be filtered:

- dry smokes
- powder (up to 0,3 microns)
- smoke electrostatically charged

### Contaminants that can NOT be filtered:

- ⇒ water vapors also in low concentration
- ⇒ oil vapors
- ⇒ large amounts of dust
- ⇒ metal shavings, iron filing dusts and waste generally
- ⇒ Gas

### Absolutely to avoid:

- ⇒ metal dusts also fine
- ⇒ fumes produced by combustion of organic and not materials (wood, coal, gasoline, etc.)

only CBK, CBK-G, CCK-REVO  
Avoid snow accumulating

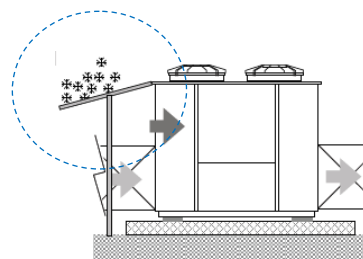
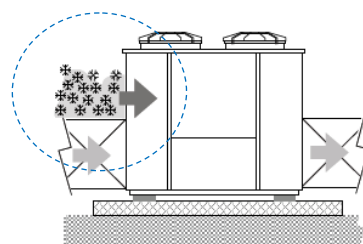

## External air hood CBK, CBK-G, CCK-REVO configurations

1 - APRIRE CUFFIA ARIA ESTERNA – All'interno ci sono le finiture DX e SX, rete AE + viti di fissaggio

1 – OPEN THE EXTERNAL AIR HOOD – Inside there are right and left parts, grid EA + fixing screws

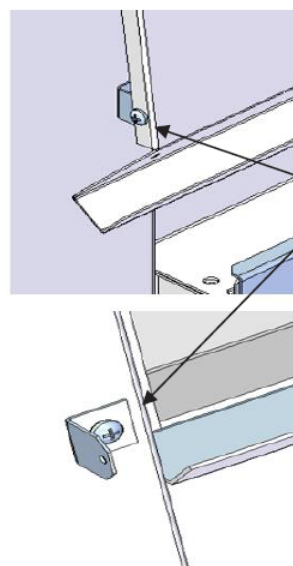
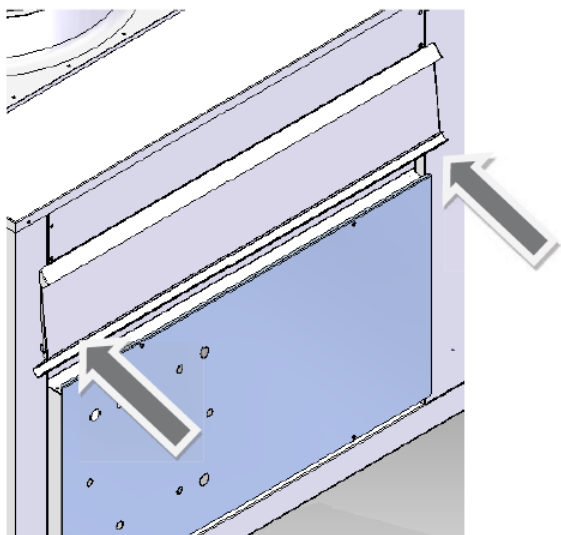

Togliere viti e  
staffa di fissaggio  
Remove screws  
and  
mounting bracket

2 - FISSARE LE FINITURE DX E SX - Esternamente e internamente, sugli appositi fori con le viti in dotazione.

2 – FIX RIGHT and LEFT PARTS - With screws supplied, on the appropriate holes internal and external side.

### FISSAGGI ESTERNI - EXTERNAL FIXING

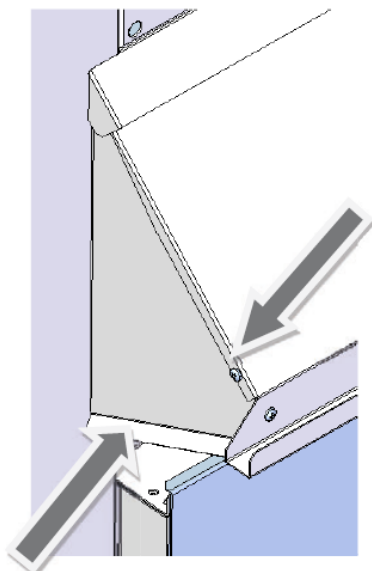

### FISSAGGI INTERNI - INTERNAL FIXING

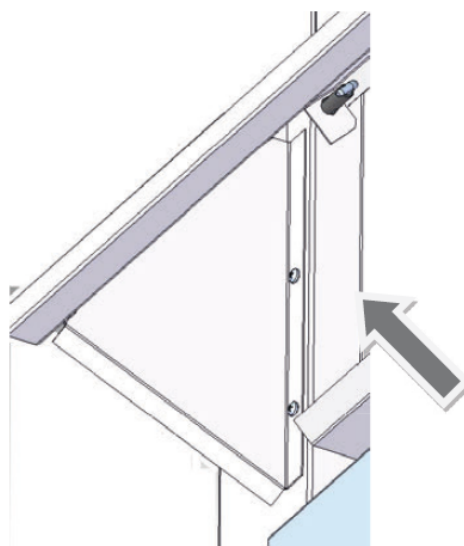

Le pieghe in basso devono andare verso l'esterno della cuffia !

The folds on the bottom must be installed on the external side of the air hood !

3 - FISSARE LA RETE ARIA ESTERNA ( AE )- Sugli appositi fori con le viti in dotazione.

3 - FIX GRID EXTERNAL AIR ( EA )- With screws supplied, on the appropriate holes.

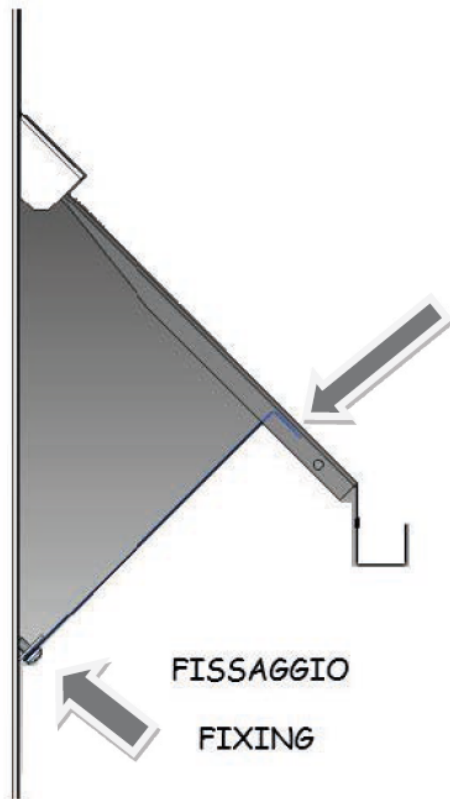

La piega deve andare verso l'esterno della cuffia

The fold must be installed on the external side of the air hood

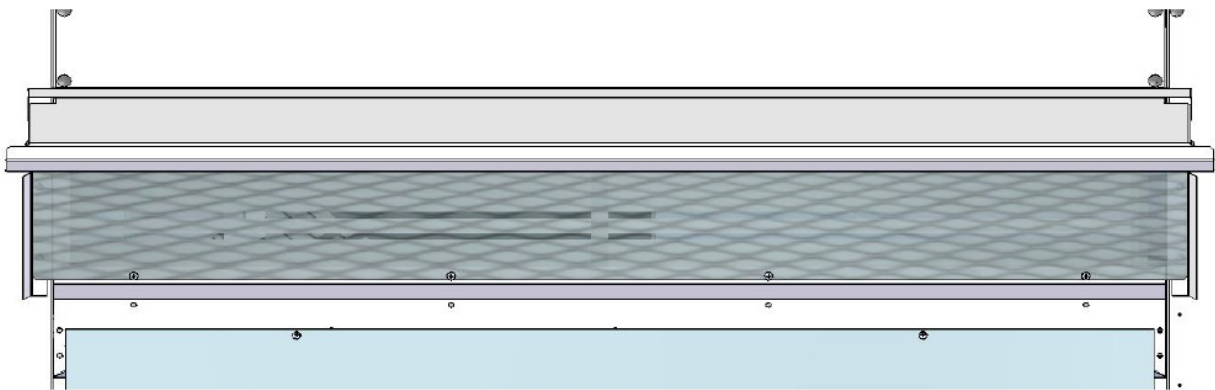



## Gas heating module

### Option

Burner with low pollutant emissions (NO<sub>x</sub> below 80 mg/kWh), in line with Class 5 of the EN 676 European standard is supplied with a gas increase control for methane or LPG.

The heating module with burner includes:

- hot air generator powered with methane
- kit for transformation of power with liquefied petroleum gas (LPG)
- kit of steel chimney for exhaust fumes
- all the control and safety devices

⇒ *The component requires gas supply (gas connections to be made by the Customer).*

⇒ *The location of the unit and the fume drain mode must comply with laws and standards in force in the Country of use.*

⇒ *The Customer may choose the flue chimney.*

⇒ *The Customer is responsible for mounting the chimney kit during installation.*

⇒ *Based on the specific installation requirements, the length of the chimney can be increased with suitable joints and fittings (not supplied by Clivet).*

### Gas connection

- Read the gas heating module manual.
- Connection must be carried out by qualified personnel.
- use certified components and comply with the local standards in force
- install on the gas connection: tap, large section filter and anti-vibration joint
- check the supply pressure is correct and stable, in particular where more uses are inserted on the same line.

### System maintenance booklet

- It must be kept in the place of installation of the unit
- It must be filled-in upon commissioning
- It must be updated with the results of the periodical checks, of the routine and extraordinary maintenance interventions.

### Interventions

For start-up, ordinary and extraordinary maintenance of the gas module, contact the local technical assistance of the manufacturer of the gas module.

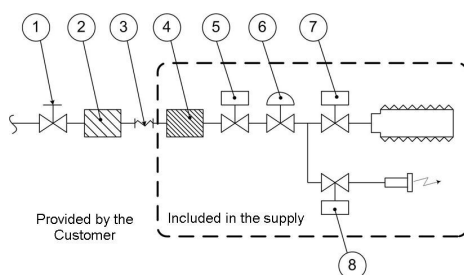

1. Gas tap
2. Gas filter (large section)
3. Anti-vibration joint
4. Gas filter (small section)
5. Safety gas solenoid valve
6. Pressure stabiliser
7. Main gas burner solenoid valve
8. Pilot burner gas solenoid valve

- A. Apply the flat adhesive gasket 15x5 on the Gas Module flange perimeter to guarantee the absence of air bypass.
- B. Fix with screws the flue supporting bracket to the GM frontal panel
- C. Fix the extensions with clamps to the flue supporting bracket
- D. Fix the suction terminals in ambient and the fuel components (curves, extensions, terminals) by the corresponding gaskets

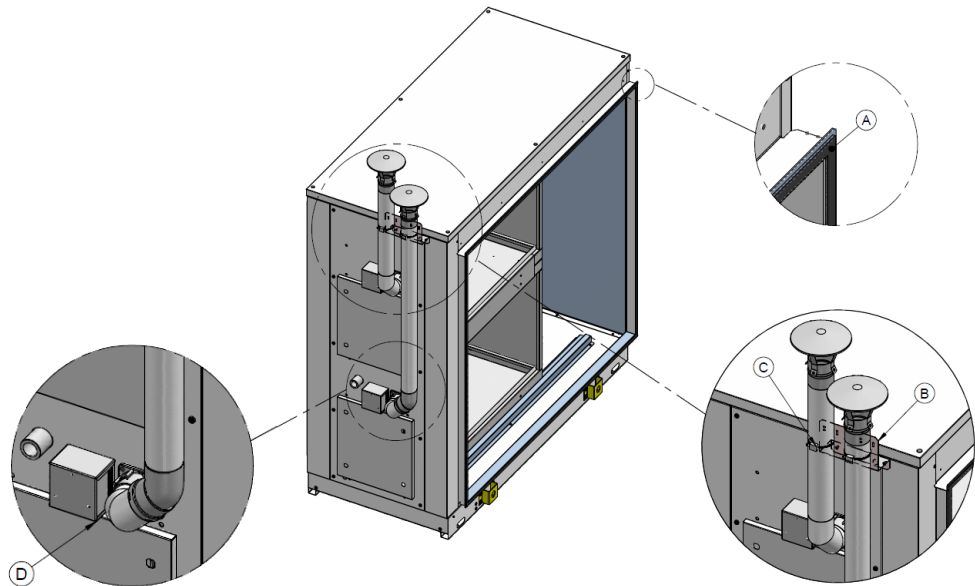

- 1 Approach the unit to the Gas Module.
- 2 match the supply flanges by means of the supplied terminals.
- 3 tighten screws
- 4 guarantee the absence of air bypass.

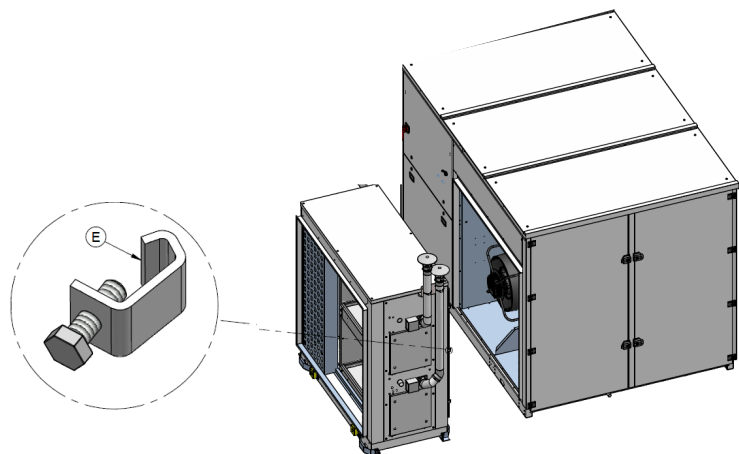

Connections performed by costumer

For a correct reading of the flow temperature, install the BT2-TC flow probe at 300cm from the gas module, in the case of a straight section of the duct, or at least 50 cm after the first curve, so that the air temperature is mixed properly.

Install the probe inside a plastic or metal tube to support, repair and ensure safety from bad weather or during maintenance

Inside the treatment area and the gas module there are the interfacing cables between the unit and the gas module (detail A)

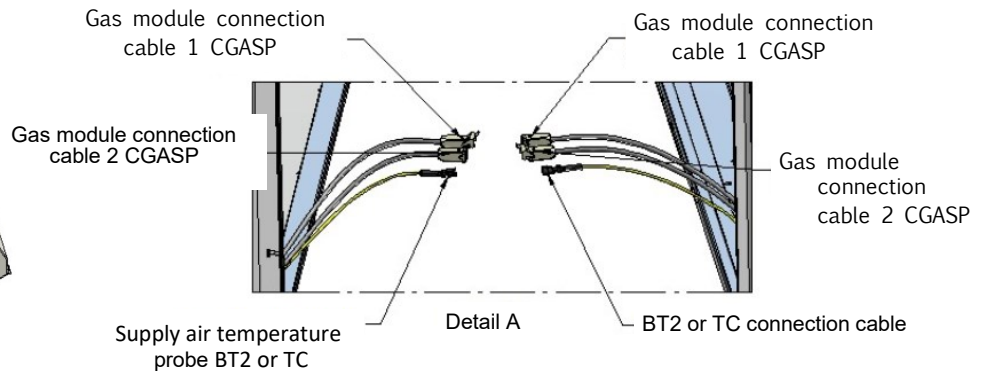
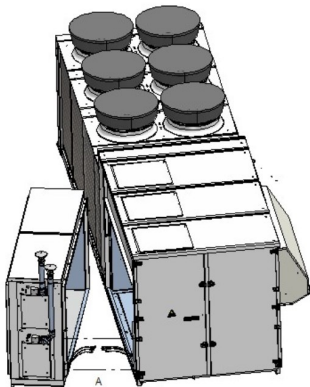
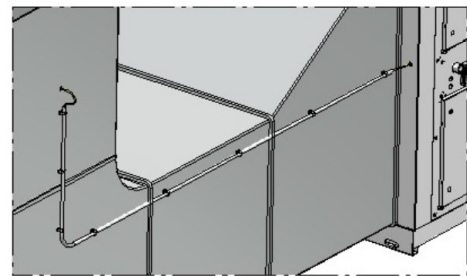
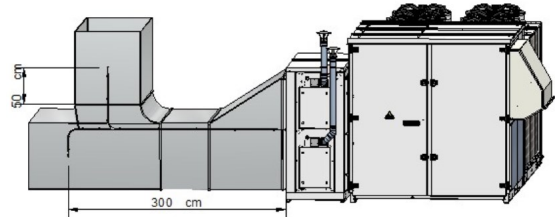

Gas burner does NOT operate with heat pump

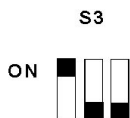

Gas burner CAN operate with heat pump



Main board: DIP SWITCH



### Gas use features

		<b>35kW</b>		<b>44kW</b>		<b>65kW</b>		<b>82kW</b>		<b>100kW</b>		<b>130kW</b>		<b>160kW</b>	
		min	max	min	max	min	max	min	max	min	max	min	max	min	max
Rated heating capacity	kW	7,6	34,8	8,5	41	12,4	65	16,4	82	21	100	12,4	130	16,4	164
Efficiency Hi (P.C.I.)	%	107	96,3	105,9	96,2	108,1	96,8	108,4	97,6	108,4	97,2	108,1	96,8	108,4	97,6
Efficiency Hs (P.C.S.)	%	96,4	86,8	95,4	86,7	97,4	87,2	97,6	87,9	97,8	87,5	97,4	87,2	97,6	87,9
Max condensation produced	l/h	0,9		1,1		2,1		3,3		2,7		4,2		6,6	
Carbon monoxide CO (0% di O <sub>2</sub> )	ppm	<5		<5		<5		<5		<5		<5		<5	
Nitrogen oxides - NO <sub>x</sub> (0% di O <sub>2</sub> )		42 mg / kWh 24 ppm		33 mg / kWh 19 ppm		39 mg / kWh 22 ppm		32 mg / kWh 18 ppm		41 mg / kWh 23 ppm		40 mg / kWh 23 ppm		34 mg / kWh 19 ppm	
Available flue pressure	Pa	90		90		120		120		120		120		120	
Gas connection diameter	GAS	UNI ISO 228/1 - G 3/4"		UNI ISO 228/1 - G 3/4"		UNI ISO 228/1 - G 3/4"		UNI ISO 228/1 - G 3/4"		UNI ISO 228/1 - G 3/4" M		UNI ISO 228/1 - G 1 1/2"		UNI ISO 228/1 - G 1 1/2"	
Flue pipe diameter	mm	80		80		80		80		80		2 x 80		2 x 80	
Seasonal space heating energy efficiency [EU Reg./2281/2016] [η <sub>sp,h</sub> ]	%	92,1		90,8		93,2		93,2		93,1		93,9		94	
Emission efficiency [EU Reg./2281/2016] [η <sub>sflow</sub> ]	%	97,3		97		97,4		97,1		97		98,1		97,9	
Power supply pressure (for gas G20)	mbar	20 [min 17 - max 25]													
Gas consumption @15°C - 1013 mbar (for G20 gas)	m <sup>3</sup> /h	0,8	3,69	0,9	4,44	1,31	6,88	1,74	8,68	1,9	10,58	1,31	13,76	1,74	17,36

## UV-C lamps

### Option

#### Caution

⇒ Direct radiation device: causes eye irritation and skin rashes.

⇒ Any maintenance operation must be carried out with the lamps off.

UV-C lamps use ultraviolet radiation to purify the air from the development of bacteria, molds, fungi and viruses.

The bactericidal and virucidal action is achieved with low pressure mercury lamps through direct radiation of the air flow with rays of a wavelength of 254 nm.

The option is installed in a separate module, external to the unit, with a dedicated electrical panel and separate power supply and is activated by the machine logic when the supply fans are operating.

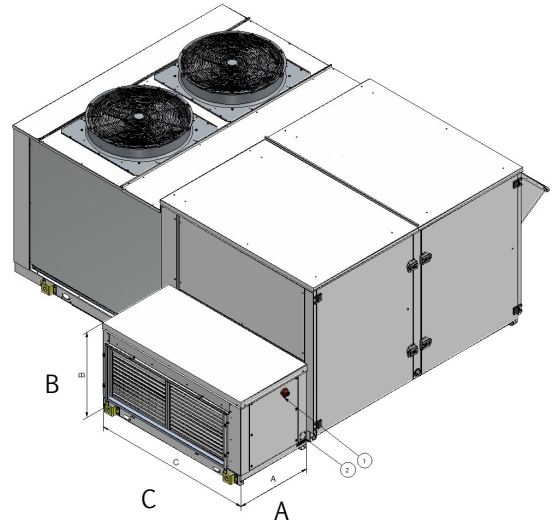

	A (mm)	B (mm)	C (mm)	FLI (kW)	FLA (A)
<b>20.2</b>	780	773	1470	0,3	1,3
<b>28.2</b>	780	773	1895	0,5	2
<b>40.4</b>	1080	1070	1890	0,6	2,6
<b>56.4</b>	1080	1070	1890	0,6	2,6

Please refer to the specific diagram of the accessory.

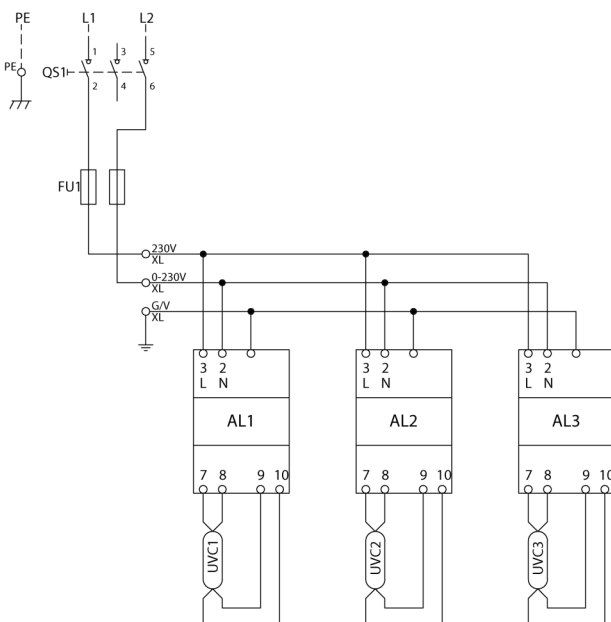

#### Components legend

QS1	Sezionatore generale General disconnect Sectionneur général Allgemeiner Trennschalter Seccionador general
FU1	Portafusibile generale General fuse holder Porte-fusible général Allgemeiner Sicherungshalter Portafusibles general
AL1	Alimentatore lampada UV-C 1 UV-C lamp power supply 1 Alimentation lampe UV-C 1 Stromversorgung für UV-C-Lampe 1 Fuente de alimentación de la lámpara UV-C 1
AL2	Alimentatore lampada UV-C 2 UV-C lamp power supply 2 Alimentation lampe UV-C 2 Stromversorgung für UV-C-Lampe 2 Fuente de alimentación de la lámpara UV-C 2
AL3	Alimentatore lampada UV-C 3 UV-C lamp power supply 3 Alimentation lampe UV-C 3 Stromversorgung für UV-C-Lampe 3 Fuente de alimentación de la lámpara UV-C 3
UVC1	Lampada UV-C 1 UV-C lamp 1 Lampe UV-C 1 UV-C-Lampe 1 Lámpara UV-C 1
UVC2	Lampada UV-C 2 UV-C lamp 2 Lampe UV-C 2 UV-C-Lampe 2 Lámpara UV-C 2
UVC3	Lampada UV-C 3 UV-C lamp 3 Lampe UV-C 3 UV-C-Lampe 3 Lámpara UV-C 3

#### Terminals

XL	
G/V	○
0-230V	○
0-230V	○

## Enthalpy wheel

### Option

The enthalpy wheel allows the efficient transfer of sensitive and latent heat from the exhausted air extracted from the building to the fresh air and vice versa, thanks to the hygroscopic treatment of the exchange surface.

The option is suitable for applications with high percentages of outdoor air and considerable difference between outdoor and indoor temperature conditions.

In free-cooling mode, the wheel is stopped automatically.

The option is provided with a separate module that can be easily connected to the unit during installation.

The enthalpy wheel energy recovery module comprises:

- Enthalpy wheel
- Extraction fans (RAD/EC)
- G4 filters (ISO 16890 Coarse 50%) upstream of the rotor for both flows
- Control and safety devices

The wheel fans and motor must be electrically connected to the unit's control box. Refer to the wiring diagram for the electrical connection.

The module is only compatible with the CBK-G construction configuration and with the return section in position R3 (from below); it is also compatible with the available heat integration system .

Size	A (mm)	B (mm)	C (mm)	FLI (kW)	FLA (A)
<b>20.2</b>	1300	1450	1750	7,92	12,4
<b>28.2</b>					
<b>40.4</b>	1600	1885	2640	8,17	12,8
<b>56.4</b>					

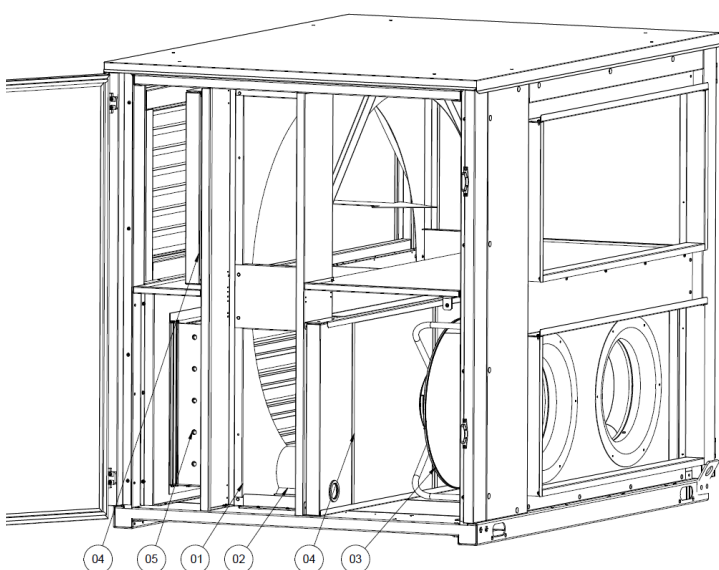
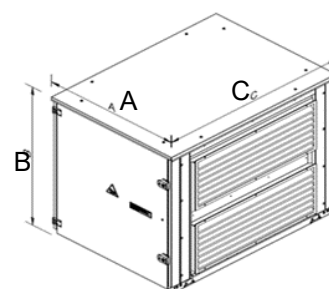

1	Enthalpy wheel
2	Enthalpy wheel motor
3	Extraction fans
4	G4 filters
5	Overpressure damper

### Assembly

- 1 Remove the fasteners on the side flanges of the unit's exhaust port
- 2 Move the enthalpy wheel module closer to the unit
- 3 Electrically connect the enthalpy wheel module
- 4 Couple the flanges
- 5 Attach terminal E shown in the figure
- 6 Ensure the complete absence of air bypass

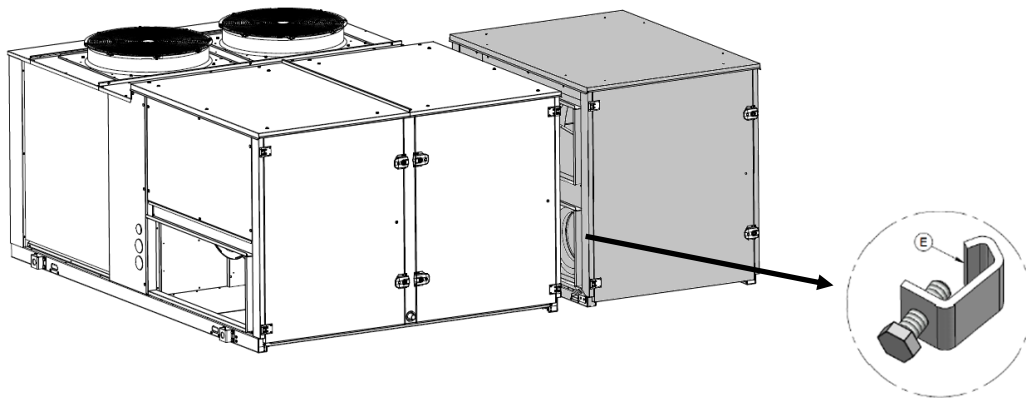

Main board: DIP SWITCH



## Condensate drain

The siphon and the relative fixing clamp are supplied with the unit. The condensate must be disposed in order to avoid damages to people and things.

- Unit discharge fitting: the connection must not transmit mechanical stresses and must be performed taking care not to damage the unit discharge fitting.
- The connection between the attachment and the siphon must be hermetically sealed (A)
- The piping must have adequate slope to allow out flow.
- Anchor the ducting with an adequate number of supports. Otherwise are generated duct failures and air locks that prevent the runoff.
- Insulate the duct and the siphon to avoid the condensate drippings.
- Connect the condensate discharge to a sewerage drainage network.
- DO NOT use white water or drainage networks to avoid the aspiration of odours in the case of evaporation of water contained in the siphon.
- Check at the end of the work, the regular condensate runoff pouring some water in the tray.

The maximum vacuum in the suction chamber of the treatment fan must not exceed 400 Pa.

In the event that the system provides for a major depression, the condensate drain must be carried out in compliance with the sizing criteria indicated below.

Provide a siphon that, eliminating the negative pressure caused by the fan, prevents the air intake from the discharge duct.

Siphon height calculation

$$T = 2P$$

$$S = T/2$$

P is the pressure determined by the fan in correspondence of the condense collection bowl (approx. 1 mm = 9.81 Pa)

Example :

$$P = 300 \text{ Pa} = 30 \text{ mm}$$

$$T = 2P = 60 \text{ mm}$$

$$S = T/2 = 30 \text{ mm}$$

## Condensation in winter operation

When a heat pump is operating it produces a considerable amount of water due to the defrosting cycles of the external coil.

The condensate must be disposed in order to avoid damages to people and things.

## Risk of freezing

Prevent the risk of freeze if the unit, drain or plumbing connections can be subject to temperatures close to 0°C.

- isolate the piping
- protect the piping with heating cables laid underneath the insulation

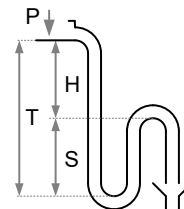
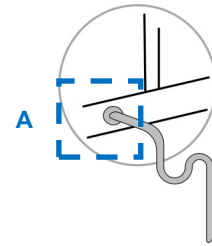



## Immersed electrode humidifier

### Option

Connexion humidificateur: 1/2" M

### Supply water

The humidifier must be supplied with mains water having the following features:

- pressure between 0.1 and 0.8 Mpa (1 – 8 bar)
- temperature between 1 and 40°C

Do not use:

- water treated with softeners: it can corrode the electrodes and form foam with possible faults/malfunctionings
- pit, industrial or potentially polluted (chemically or bacteriologically) water
- disinfectants or anti-corrosive substances mixed with water, as potentially irritating

Supplying the humidifier with water treated with reverse osmosis filtering system gives the following advantages:

- reduces limescale deposits
- reduces energy consumptions
- reduces maintenance costs
- increases humidifier duration

Check that the filter guarantees a water flow rate higher than the flow rate of the installed humidifier.

### Limit values for the supply water

Respect the limits indicated in the table

No relation can be demonstrated between water hardness and conductivity.

Limit values for the supply water	conductivity	medium-low		medium-high	
		min	max	min	max
Hydrogen ions	pH	7	8,5	7	8,5
Specific conductivity at 20°C	µS/cm	125	500	300	1250
Total dissolved solids	TDS mg/l	(1)	(1)	(1)	(1)
Dry residue at 180°C	R <sub>180</sub> mg/l	(1)	(1)	(1)	(1)
Total hardness	TH mg/l CaCO <sub>3</sub>	50 <sup>(2)</sup>	250	100 <sup>(2)</sup>	400
Temporary hardness	mg/l CaCO <sub>3</sub>	30 <sup>(3)</sup>	150	60 <sup>(3)</sup>	300
Iron + Manganese	mg/l Fe+Mn	0	0,2	0	0,2
Chlorides	ppm Cl	0	20	0	30
Silica	mg/l SiO <sub>2</sub>	0	20	0	20
Residual chlorine	mg/l Cl <sup>-</sup>	0	0,2	0	0,2
Calcium sulphate	mg/l CaSO <sub>4</sub>	0	60	0	100
Metallic impurities	mg/l	0	0	0	0
Solvents, diluents, soaps, lubricants	mg/l	0	0	0	0

(1) Values depending on specific conductivity; in general:

$$TDS \cong 0,93 * \sigma_{20}; R_{180} \cong 0,65 * \sigma_{20}$$

(2) not lower than 200% of the chloride content in mg/l of Cl<sup>-</sup>

(3) not lower than 300% of the chloride content in mg/l of Cl<sup>-</sup>

### Drainage water

It can reach a temperature of 100°C.

It contains the same substances of the supply water but in higher concentration.

As it is not toxic, it can be disposed of with white waters.

## Heating coil

### Option

Max. operating pressure = 10 bar

Water flow modulation valve already mounted and wired on the machine

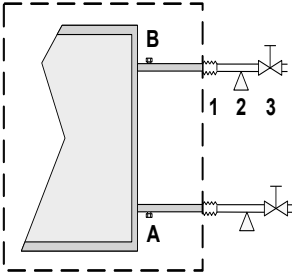

- A drain valve
- B vent valve

Provided by the customer:

- 1 anti-vibration devices
- 2 piping supports
- 3 Shut-off valves

Main board: DIP SWITCH

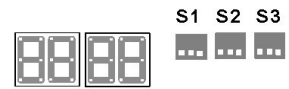

Water coil CAN operate  
with heat pump

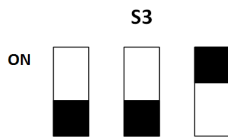

Water coil does NOT  
operate together with  
Heat Pump

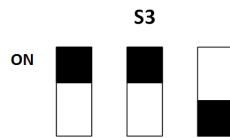

Hot water coil for heat  
recovery from refrigeration  
units - can operate together  
with heat pump



## AERAILIC CONNECTIONS

The dimensioning and correct execution of the aeraulic connections are fundamental to guarantee good unit operation and adequate level of silence in the room.

When designing and manufacturing the ducting, consider PRESSURE DROPS, AIR FLOW AND SPEED that must be consistent with the unit features.

Particularly consider that pressure drops higher than the unit useful prevalence, lead to reduction in flow rate, with consequent unit failures.

- the weight of the ducts must not burden on the connection flanges
- place anti-vibration joints between ducts and unit
- connection to the flanges and between the sections of the ducts must guarantee air seal, avoiding dispersions penalising the overall efficiency of the system
- limit the pressure drops by optimising the path, the type and number of bends and junctions
- use wide bends evaluating the opportunity of equipping them with deflectors (in particular with high air speed or bends with reduced radius)

### Treated air ducting

The internal surface of the duct must be smooth, enable its washing and must not contaminate the air.

Thermally isolate the ducts flanges and silencers to avoid energy losses and forming of condensation.

#### DIFFUSERS INLETS GRILLES

A correct diffusion of the air in the room is determining for the level of comfort.

When choosing and positioning the grilles, inlets and diffusers, avoid:

- excessive air speed
- forming of stagnant and stratification areas
- cold air supplied in room
- forming of localised currents (also due to uneven distribution of air)
- excessive room temperature variations, vertically and horizontally
- short circuits of the supply air towards the return air

For sound comfort, consider that:

- the air diffusers must be chosen verifying the sound power generated at nominal flow rate conditions
- the cut-off to diffusers must be carried out with flexible elements
- the return grilles must be widely dimensioned

Isolate the channels

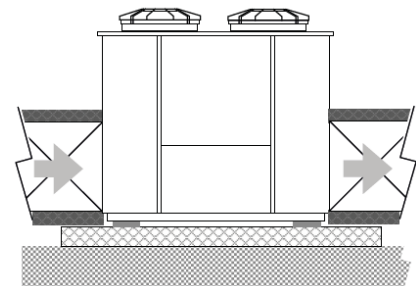

Isolate the flanges

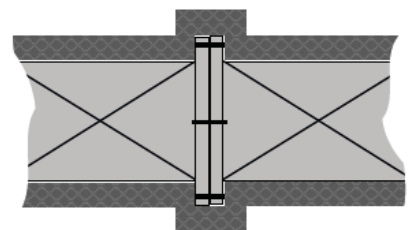

The characteristics of the electrical lines must be determined by specialized personnel able to design electrical installations; moreover, the lines must be in conformity with regulations in force.

The protection devices of the unit power line must be able to stop the presumed short circuit current, whose value must be determined in function of system features.

The power cables and the protection cable section must be defined in accordance with the characteristics of the protections adopted.

All electrical operations should be performed by trained personnel having the necessary requirements by the regulations in force and being informed about the risks relevant to these activities.

Operate in compliance with safety regulations in force.

### Electrical data

The serial number label reports the unit specific electrical data, included any electrical accessories.

The electrical data indicated in the technical bulletin and in the manual refer to the standard unit, accessories excluded.

Refer to the electrical data report on the serial number label:

- Tensione
- F.L.A.: full load ampere, absorbed current at maximum admitted conditions
- F.L.I.: full load input, full load power input at max. admissible condition
- Electrical wiring diagram Nr

### Connections

refer to the unit electrical diagram (the number of the diagram is shown on the serial number label).

verify that the network has characteristics conforming to the data shown on the serial number label.

Before starting work, verify that the sectioning device at the start of the unit power line is open, blocked and equipped with cartel warning.

Primarily you have to realize the earthing connection.

Shelter the cables using adequate measure fairleads.

Before power the unit, make sure that all the protections that were removed during the electrical connection work have been restored.

### Power supply network requirements

- 1 The short circuit capacity of the line must be less than 15 kA
- 2 The units can only be connected to TN, TT distribution systems
- 3 Voltage 400-3-50 +/-10%
- 4 Phase unbalance < 2%
- 5 Harmonic distortion less than 12% (THDv<12%)
- 6 Voltage interruptions lasting no longer than 3ms and with at least 1 s between each one
- 7 Voltage dips not exceeding 20% of the RMS value, lasting no longer than a single period (50Hz) and with at least 1 s between each dip.
- 8 Earth cable as specified in the table:

Cross-section of the line conductors (mm <sup>2</sup> )	Minimum cross-section of the protective conductor (PE) (mm <sup>2</sup> )
$S \leq 16$	S
$16 < S \leq 35$	16
$S > 35$	S/2

### Signals / data lines

Do not overpass the maximum power allowed, which varies, according to the type of signal.

Lay the cables far from power cables or cables having a different tension and that are able to emit electromagnetic disturbances.

Do not lay the cable near devices which can generate electromagnetic interferences.

Do not lay the cables parallel to other cables; cable crossings are possible, only if laid at 90°.

The type of cable must be suitable for RS-485 serial data communication.

A 3-pole shielded bus cable is required.

The data transmission bus cable must be verified according to the type of installation in which it will be placed and must comply with local standards.

The bus cable must comply with non-prescribed local electrical standards (e.g. insulation, voltages, flame propagation, etc.).

The cable shield must be grounded at a single point free from disturbances.

In order to ensure correct communication, the earth connection of the shield can also be configured differently depending on the area and the types of interference.

Allowed topology: daisy-chain (enter and exit). Other topologies such as "ring" or "star" are not allowed.

Do not use cable lugs on the communication bus.

If the unit is the last device on the Modbus network, it may be necessary to install a terminating resistor (120 Ohm) at the end of the bus between X and Y (Rx / Tx + and Rx / Tx-).

Maximum line length:

HMI 50 m - 300 m with external power

RS-485 1200 m

### Power input

Fix the cables: if vacated may be subject to tearing.

The cable must not touch the compressor and the refrigerant piping (they reach high temperatures).

Standard unit:       minimum section 50 mm<sup>2</sup>  
                           maximum section 95 mm<sup>2</sup>

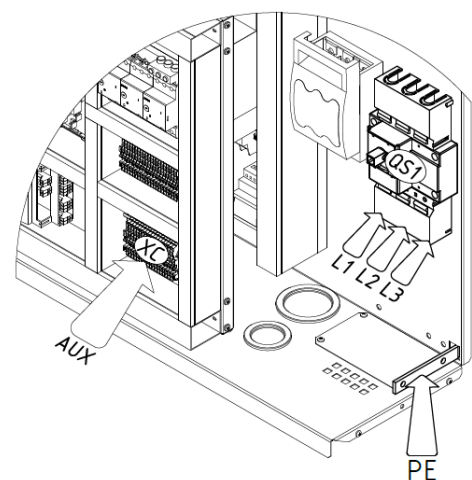

XC

Terminal block connections by the customer

Connections performed by customer

ALM	Segnalazione blocco cumulativo Signalisation alarme Sammasbomledning Señalización bloque cumulativo	2 Pg. 302	EXFLOWC 098_4 Pg. 302	4...20mA (1) Segnale 4...20mA (Estrazione forzata) Signal 4...20mA (Extraction for C&A) 4...20mA Signal (Zwangsextraktion) Señal 4...20mA (Extracción forzada)	EXFLOWC 098_4 Pg. 302
ALC	Contatto pulito da impianto di segnalazione allarme antincendio Free contact from signalling system of fire alarm Contact libre de réalisation de signalisation alarme d'incendie Contato limpio de instalación de señalización alarma antincendio	EXFLOWC 098_4 Pg. 302	4...20mA (2) Segnale 4...20mA (Modulazione portata aria mandata) Signal 4...20mA (Modulation du débit d'air soufflé) 4...20mA Signal (Modulation de l'air soufflé) Señal 4...20mA (Modulación del flujo de aire de suministro)	PVMV 061_12 Pg. 312	
EXT1 EXT2 EXT3 EXT4	Contatto pulito estrattore ambiente Contact libre extracteur ambiant Potenti affier Kontakt des Raumabzug Contacto libre extractor ambiente	EXFLOWC 098_4 Pg. 302	0-10V (1) Segnale 0-10V (Demand limit) Signal 0-10V (Demand limit) 0-10V Signal (Demand limit) Señal 0-10V (Demand limit)	DML 820_1 Pg. 301,2	
HLVE	Lampada segnalazione stato ventilatore d' estrazione Voyant d'état du ventilateur d'extraction Lampe de signalisation état compresseur Lámpara indicadora de estado del ventilador de extracción	CCK-REVIO 025_70 Pg. 30,12	0-10V (2) Segnale 0-10V (Segnale sonda CO2) Signal 0-10V (Signal sonde CO2) 0-10V Signal (Signal sonde CO2) Señal 0-10V (Señal sonda CO2)	PPAQC 449_5 Pg. 322	
HLW	Lampada segnalazione stato ventilatore di mandata Lampe de signalisation de l'état ventilateur de reboisement Signal Lampe des Zustandes des Druckventilators Lámpara indicadora estado ventilador de impulsión		0-10V (3) Segnale 0-10V (Controllo umidificatore esterno) Signal 0-10V (contrôle externe de l'humidificateur) 0-10V Signal (externe Befeuchtesteuerung) Señal 0-10V (Control de humidificador externo)	PUE 447_34 Pg. 322	
HL1	Lampada di segnalazione stato compressore Compressor status signal lamp Lampe de signalisation état compresseur Lámpara de señalización estado compresor		SA7 Enabling selector to the humidifier manual discharge S validation à la décharge manuelle humidificateur Selektor habilitación a b. de descarga manual humidificador	PRUM 447_27 Pg. 322	
KPC	Comando pompa/ or colatore della batteria litigeativa Commande pompe/le potome de circulation de la batterie supplementaire Pumpe/Zirkulationpumpe-Steuerung, der Zusatzbatterie Mando bomba/bomba de circulación de la batería complementaria		RS485 Modbus per il cliente Modbus pour le client Modbus für den Kunden Modbus para el cliente		
SA1	Selettore on/off remoto Remote on/off selector Selecteur ON/OFF déporté Selektor on/off remoto		MDMTUX 961_4 Pg. 302	MDMTUX 961_4 Pg. 302	
SA5	Selettore remoto "estate/inverno" Remote selector "summer/winter" Selecteur déporté "été/hiver" Fernwähler "Sommer/Winter/Sommer" Selector remoto "verano/invierno"		MDMTX 961_6 Pg. 302	MDMTX 961_6 Pg. 302	

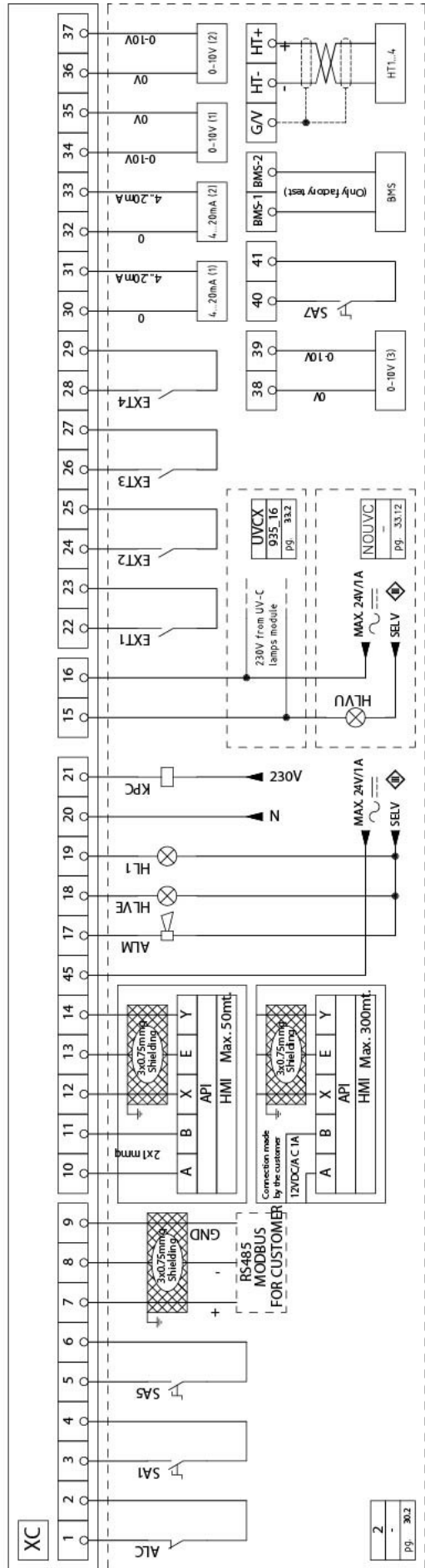
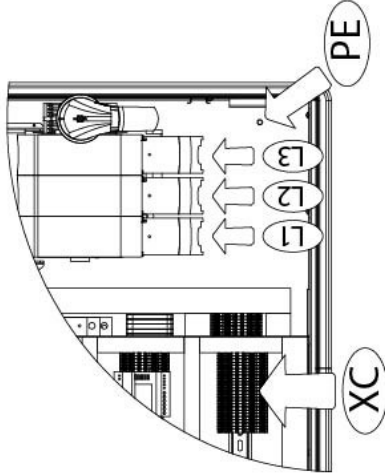

## ON-OFF remote

MENU > Assistance setting\* >





Operation parameter > P05 EnONOFF

\*Assistance setting: accesso al menu protetto da password

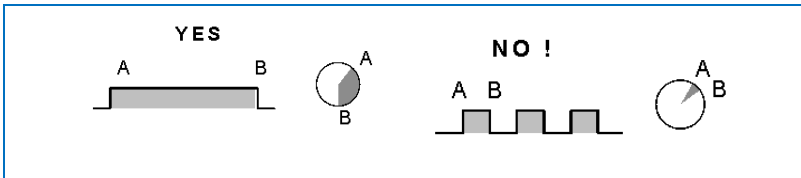
Do not perform short On Off cycles

Do not use the remote On Off with thermoregulation function.



1.05 EnOnOff	ON / OFF from:	
= 0	digital input SA1	Unit ON  Unit OFF 
= 1	controller	
= 2	BMS	

## Wall mounted control.

Before proceeding, make sure you have:

Name	Nr.	
Wired Controller	1	KJRH-120H/BMKO-E
Cross round head wood mounting screw	3	For Mounting on the Wall
Cross round head mounting screw	2	For Mounting on the Electrical Switch Box
Plastic bolt	2	This accessory is used when install the centralized control inside the electric cabinet
Plastic expansion pipe	3	For mounting on the Wall

## Installation

The room control is equipped with an internal temperature probe that can be used to substitute the return air temperature probe installed in the unit (see the follow-me chapter).

If the thermoregulation is switched on the room control temperature probe (follow-me function enabled), do not place the room control near sources that can alter the internal temperature detected (radiators, openings to the outside, etc.). This may cause overheating / undercooling of the environment and abnormal operation of the unit.

Do not install the unit in a place with much oil, steam, sulfide gas.

Otherwise, the product may deform and fail.

Check that all the components listed below are present.

Circuit of Wired Remote Controller is low voltage circuit. Never connect it with a standard 220V/380V circuit or put it into a same Wiring Tube with the circuit.

The shielded cable must be connected stable to the ground, or transmission may fail.

Do not attempt to extend the shielded cable by cutting, if it is necessary, use Terminal Connection Block to connect.

After finishing connection, do not use Megger to have the insulation check for the signal wire

### Back cover installation

- 1) Use straight head screwdriver to insert in the buckling position in the bottom of wired controller, and spin the screwdriver to take down the back cover. (Pay attention to spinning direction, otherwise will damage the back cover!)
- 2) Use three M4X20 screws to directly install the back cover on the wall.
- 3) Use two M4X25 screws to install the back cover on the 86 electrician box, and use one M4X20 screws for fixing on the wall.
- 4) Adjust the length of two plastic screw bars in the accessory to be standard length from the electrical box screw bar to the wall. Make sure while installing the screw bar to the wall, making it as flat as the wall.
- 5) Use cross head screws to fix the wired controller bottom cover in the wall through the screw bar. Make sure the wired controller bottom cover is on the same level after installation, and then install the wired controller back to the bottom cover.
- 6) Over fastening the screw will lead to deformation of back cover.

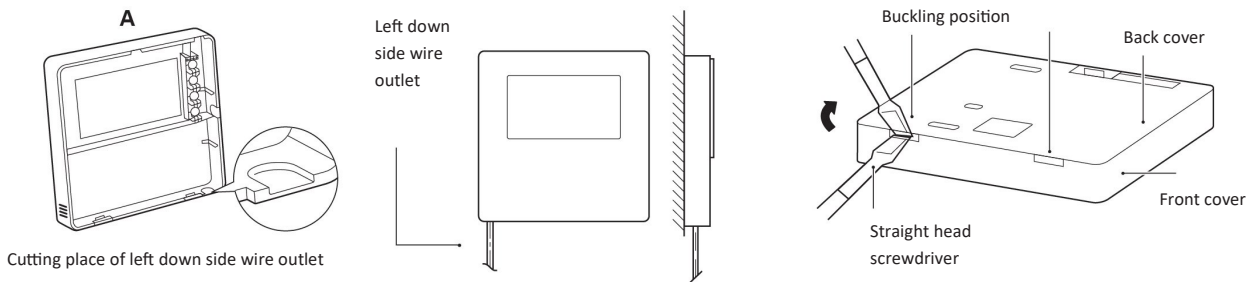

#### Wall installation

Screw hole installed on the three M4X20

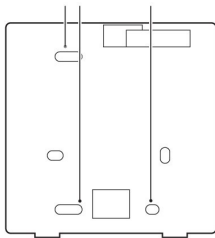

#### Installation in electrical box 86

Screw hole installed on the three M4X20

Screw hole installed on 86 Electrician box, use two M4X25

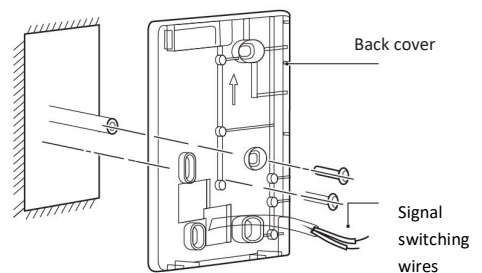



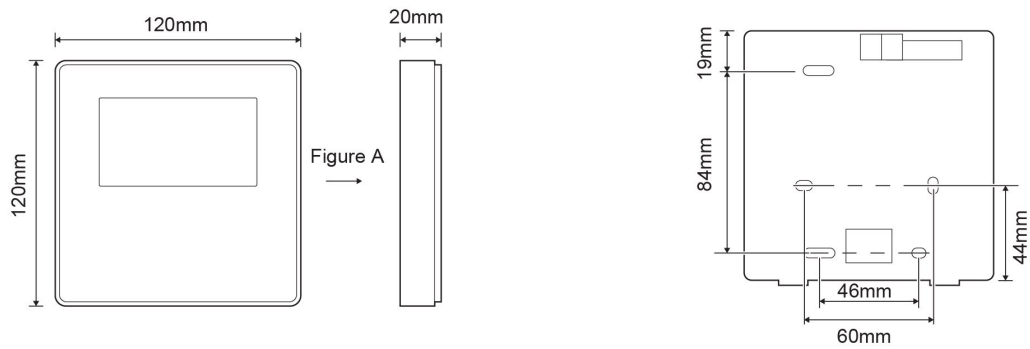

Avoid the water enter into the wired remote controller, use trap and putty to seal the connectors of wires during wiring installation.

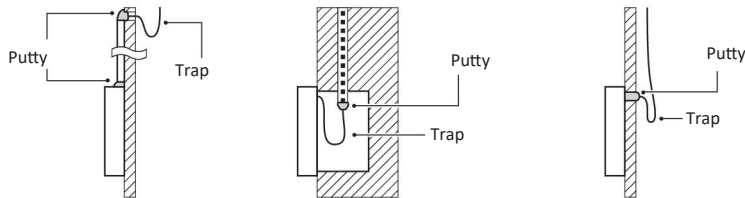
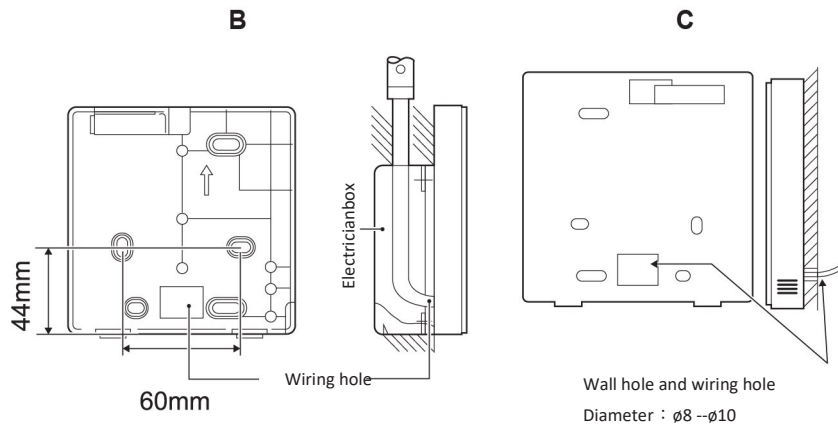

**Front cover installation**

After adjusting the front cover and then buckle the front cover; avoid clamping the communication switching wire during installation.

Correct install the back cover and firmly buckle the front cover and back cover, otherwise will make the front cover drop off.

The sensor must not be exposed to moisture.

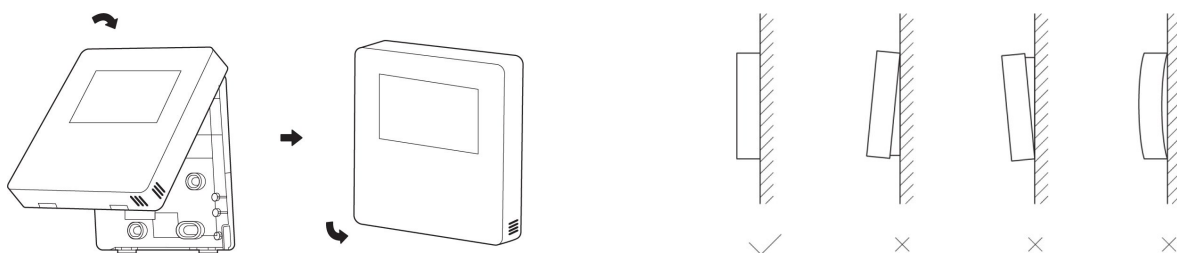

## MANAGEMENT OF TEMPERATURE AND HUMIDITY REMOTE PROBES

It is possible to install 1 up to a maximum of 4 remote temperature and humidity sensors (DPWC114000), which, if selected, are supplied separately to the unit.

The values recorded by the probe(s) can be viewed from the keypad.

The remote probe can be used for thermoregulation (MDMTX "Management of temperature ambient probes" or MDMTUX "Management of temperature and humidity ambient probes" option); in this case, if several remote sensors are installed, the average temperature and/or humidity value of the remote sensors installed is used for the control.

Refer to the wiring diagram to connect the remote probes.

The remote sensor, if selected, is connected to terminal K1-K2 of the secondary board via Modbus.

The function is enabled in the EnRemoteTH parameter, which is set with the keypad as follows:

- EnRemoteTH=0: the function is off. Thermoregulation is performed by the temperature probe and by the humidity probe (if present) installed on the unit.
- EnRemoteTH=1: the remote temperature control function is on; the temperature is controlled using the temperature value of the remote sensor (DPWC114000), while the humidity is controlled (if present) using the humidity sensor installed on the unit.
- EnRemoteTH=2: the remote humidity control function is on; the temperature is controlled using the temperature value of the sensor installed on the unit, while the humidity is controlled using the remote sensor (DPWC114000).
- EnRemoteTH=3: the remote temperature and humidity control function is on; both the temperature and humidity are controlled using the values read by the remote sensor.

### MODBUS ADDRESS:

Module address 1: 128.

Module address 2: 129.

Module address 3: 130.

Module address 4: 131.

Communication settings: 9600,8, N,2.

Communication protocol: RTU Modbus .

### Remote probe dip-switch configuration

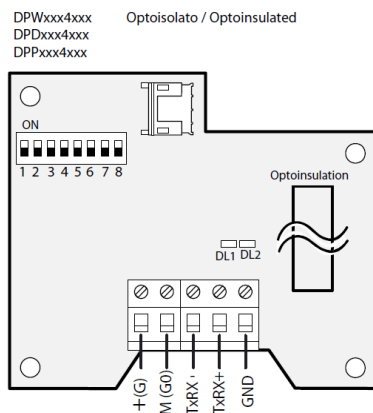

Impostazioni Dip-Switch valide per tutti i modelli

Dip-switch 1 to 5		Baud rate
1 2 3 4 5 Address 128 - 159		9600 19200
RS485 protocol		Bit Parity Stop
ON		CAREL supervisor 8 N 2
OFF		ModBus® 8 N 2
ON		CAREL supervisor 8 N 2
OFF		ModBus® (***) 8 E 1
ON		ModBus® 8 E 1
OFF		ModBus® (***) 8 E 1

\*\*\* con riconoscimento automatico del protocollo.

More info availables on Service Manual



Montaggio / Assembly / Montage / Montage / Montaje

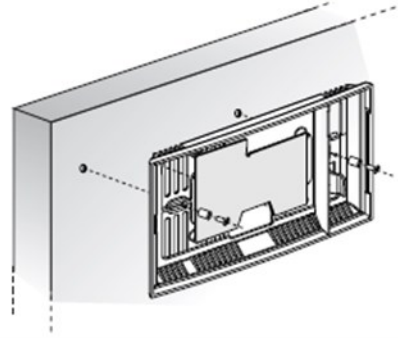

Apertura dello sportellino della sonda / Opening the sensor cover / Ouverture du volet de la sonde / Öffnen der Klappe des Fühlers / Apertura de la portezuela de la sonda

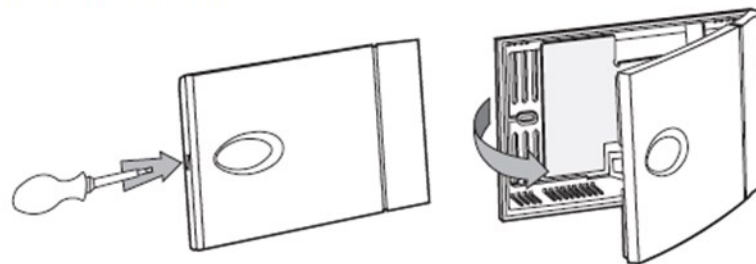

Dimensioni sonda da parete (DPW\*) (mm) / Wall probe (DPW\*) dimensions (mm) / Dimensions sonde murale (DPW\*) (mm) / Abmessungen des Wandfühler (DPW\*) (mm) / Dimensiones sonda de pared (DPW\*) (mm)

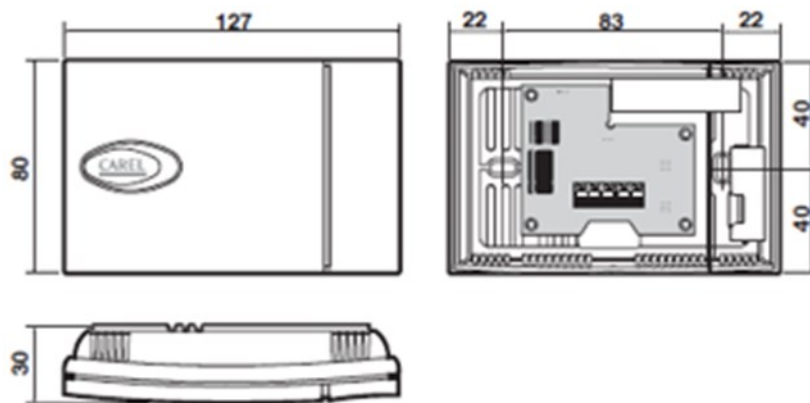

The indicated operations should be done by qualified technician with specific training on the product.

Upon request, the service centres performing the start-up.

The electrical, water connections and the other system works are by the installer.

Agree upon in advance the start-up data with the service centre.

Before checking, please verify the following:

- the unit should be installed properly and in conformity with this manual
- the electrical power supply line should be isolated at the beginning
- the unit isolator is open, locked and equipped with the suitable warning
- make sure no tension is present

⇒ *After turning off the power, wait at least 5 minutes before accessing to the electrical panel or any other electrical component.*

⇒ *Before accessing check with a multimeter that there are no residual stresses.*

### UV-C lamps

#### Option

#### Caution

⇒ *Direct radiation device: causes eye irritation and skin rashes.*

⇒ *Any maintenance operation must be carried out with the lamps off.*

### Preliminary checks

For details refer to the different manual sections.

#### Unit OFF power supply

- 1 safety access
- 2 functional spaces
- 3 air flow: correct return and supply (no bypass, no stratification)
- 4 structure integrity
- 5 fans run freely
- 6 unit on vibration isolators
- 7 condensate drain
- 8 air filters present and clean
- 9 completed aeraulic system
- 10 refrigerant circuit visual check
- 11 earthing connection
- 12 power supply features
- 13 electrical connections provided by the customer



## Start-up sequence

For details refer to the different manual sections.

### Unit ON power supply

- 1 compressor crankcase heaters operating at least since 8 hours
- 2 off-load voltage measure
- 3 phase sequence check
- 4 shut-off valve refrigerant circuit open
- 5 unit ON
- 6 load voltage measure and absorptions
- 7 liquid sight glass check (no bubbles)
- 8 check all fan operating
- 9 check air flow on outer coil (no by-pass, no stratification)
- 10 air flow rate measurement
- 11 supply, return and outdoor air temperature measurement
- 12 measure super-heating and sub-cooling
- 13 check no anomalous vibrations are present
- 14 climatic curve personalization
- 15 climatic curve personalization
- 16 scheduling personalization
- 17 fire alarm configuration \*
- 18 complete and available unit documentation

\* only if present

### Refrigeration circuit

- 1 Check carefully the refrigerating circuit: the presence of oil stains can mean leakage caused by transportation, movements or other).
- 2 Make sure that all the service outlets are closed with proper caps; if caps are not present a leak of refrigerant can be possible.
- 3 Open the valves of the refrigerant circuit, if there are any.

### Water circuit

#### Only with humidifier options - Hot water coil

- 1 Before realizing the unit connection make sure that the hydraulic system has been cleaned up and the cleaning water has been drained.
- 2 Check that the water circuit has been filled and pressurized.
- 3 Check that the shut-off valves in the circuit are in the "OPEN" position.
- 4 Check that there isn't air in the circuit, if required, evacuate it using the air bleed valve placed in the system high points.
- 5 When using antifreeze solutions, make sure the glycol percentage is suitable for the type of use envisaged.

#### NOTE

⇒ *Neglecting the washing will lead to several filter cleaning interventions and at worst cases can cause damages to the exchangers and the other parts.*

### Electric Circuit

Verify that the unit is connected to the ground plant.  
 Check the conductors are tightened as: the vibrations caused by handling and transport might cause these to come loose.  
 Connect the unit by closing the sectioning device, but leave it on OFF.  
 Check the voltage and line frequency values which must be within the limits: 400/3/50 +/- 10%  
 Check and adjust the phase balance as necessary: it must be lower than 2%

**NOTE**

⇒ Working outside of these limits can cause irreversible damages and voids the warranty.

### Compressor crankcase heaters

The crankcase heaters are managed by the unit with the following logic:

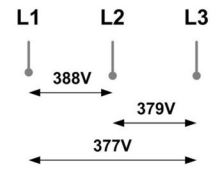

$$1) \frac{388 + 379 + 377}{3} = 381 \text{ (A)}$$

$$2) \text{MAX} - \text{A} = 388 - 381 = 7$$

$$3) S = \frac{7}{A} \times 100 = 1,83 \text{ OK}$$

ON	OFF
$T4 \leq 3^{\circ}\text{C}$ and the compressor has been stopped for at least 3 hours or $T4 \leq 3^{\circ}\text{C}$ and the power supply has just been turned on	$T4 > 4^{\circ}\text{C}$ or compressor starts

T4 = outdoor temperature

### Voltages

Check that the air and water temperatures are within in the operating limits.

Start-up the unit.

With unit operating in stable conditions, check:

- Voltage
- Total absorption of the unit
- Absorption of the single electric loads

### Scroll compressor (28.2-56.4)

The Scroll compressors have only one rotation direction. In the event it is reversed, the compressor is not immediately damaged, but increases its noise and jeopardises pumping. After a few minutes, the compressor blocks due to intervention of the thermal protection.

In this case, disconnect the power supply and reverse the 2 phases in the compressor box.

Avoid the compressor working for a long time with contrary rotation: more than 2-3 of these anomalous start-ups can damage it.

To ensure the rotation direction is correct, measure the condensation and suction pressure.

The pressures must significantly differ: upon start-up, the suction pressure decreases whereas the condensation one, increases.

The phase monitor is standard in these units and intervenes if the phases are not correctly connected.

## Remote controls

Check that the remote controls (ON-OFF etc) are connected and, if necessary, enabled with the respective parameters as indicated in the “electrical connections” section.

Check that probes and optional components are connected and enabled with the respective parameters (“electrical connections” section and following pages).

## Delivery air flow management

The air flow can be managed in 6 different ways:

1. **Standard mode**
2. **Constant air flow**
3. **Variable air flow**
4. **Constant pressure**
5. **Regulation from external 4 ~ 20 mA signal**
6. **Adjustment from Modbus FanSpeedOutBMS register**

### 1. Standard mode - Air flow calibration

The rotation speed of the supply fan remains constant in all conditions of thermal load and operating mode.

Calibration must be carried out by specialized personnel appointed by Clivet.

The real unit flow is according to the aeraulic system features.

Before checking, make sure that the system has been completed in all its parts (shunts, dampers, grilles, diffusers etc.).

Check the doors and windows of the serviced room are closed.

The unit must be calibrated while full recirculation and the airflow is quite stable.

The unit is in full recirculation during the first 60 minutes of operation.

Set the fan’s percentage of operation:

MENU>Assistance setting\*>Supply fan>P02 FanSpeedOutMand [%]

### 2 Constant air flow

#### Option

The supplied air flow rate stays constant during variations in the thermal load and head losses of the unit and system.

The ventilation remains active even when the setpoint is fulfilled.

The parameter that defines the setpoint air flow is QsetMand which is located at the following password protected path:

MENU> Assistance setting\* > Supply fan > P18 QSetMandV [m3 / h]

The option requires the installation of optional accessories.

### Standard mode

Nominal = FanSpeedOutMand

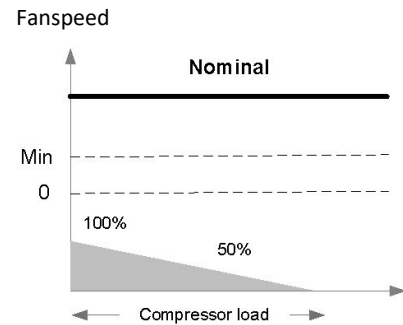

### Constant airflow

Nominal = QSetMand

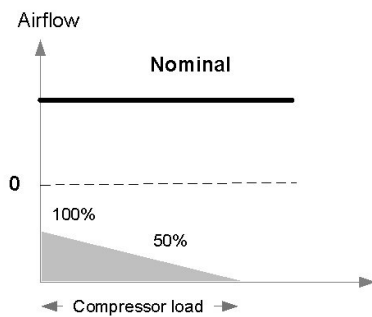

### Variable airflow

Nominal = QSetMandV

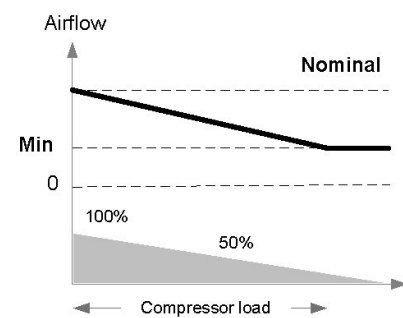

### 3 Variable airflow

#### Option

The air flow supply varies depending on the heat load, up to a minimum value compatible with the distribution system and the chosen air diffusion.

The ventilation remains active even when the setpoint is fulfilled.

The parameter that defines the setpoint air flow is the QsetMand which is located at the following password-protected path:

MENU> Assistance setting \*> Supply fan > P18 QSetMandV [m3 / h]

The air flow can be modulated up to a minimum value of not less than 60% of the set

QsetMandV value.

The option requires the installation of optional accessories

### 4 Constant pressure

#### Option

Flow regulation to maintain constant pressure in the supply duct (PVARdP) based on the pressures detected by the differential pressure sensor.

In the event of a change in the system's aeraulic load curve, it allows you to automatically vary the air flow rate in order to keep the useful static pressure set on the display by the user constant.

MENU> Assistance setting\* > Supply fan > P19 SetSupplyPPlant [Pa]

The connection of the differential sensor is as follows:

(-) atmospheric pressure positioned under the electrical panel

(+) pressure in the supply duct, positioned near the supplied air outlet of the unit

The option requires the installation of optional accessories.

### 5 Fan speed adjustment based on external 4 ~ 20mA signal

#### Option

The supplied air flow can be modulated within the minimum and maximum range, based on an external signal.

The variation will act directly on the value of the supply fan control analogue signal

### 6 Fan speed adjustment from Modbus FanSpeedOutBMS register

#### Option

The supplied air flow can be modulated within the minimum and maximum range, based on the value set via Modbus.

The variation will act directly on the value of the supply fan control analogue signal.

### "Follow me" function

Allows you to set the probe on which the thermoregulation is based.

0 = return probe installed in the unit (default)

1 = room thermostat

Settable only via HMI and from technical assistance.

ASSISTANCE SETTING > OPERATION PARAMETER P22 Followme

### EnClean function

Allows you to activate the air purification mode (EnClean parameter), set its duration (TimeClean) and specify its activation cyclicity (IntervalClean).

- MENU > Assistance setting\* > Operation parameter > EnClean / TimeClean / IntervalClean
- EnClean=0: function is not active.
- EnClean=1: The function is enabled once, starting with manual setting of parameter AirPurificationOnceEn to value 1.
- MENU > Main parameter > AirPurificationOnceEn
- EnClean=2: The function is enabled cyclically every IntervalClean hours.

During the operation of the "cleaning" function, the outside air damper is opened to the value MaxOpenExt; the exhaust fan signal is assigned equal to MaxFanEsp; the supply fan adjusts according to its control logic.



## Start-up phase

When the unit is switched on, the start-up phase begins.

During this phase the expulsion fan is stopped and the external air shutter is closed.

If the unit has just been powered up, from that moment for the next 12 minutes, if in ON, it will work in ventilation only.

The start-up phase ends when at least one of the following conditions is satisfied:

- continuous operation of the compressor for more than 60 minutes (Tregime parameter that can only be changed by personnel in charge of Clivet);
- if in Cooling T1 mode  $\langle T_{set} + 2 \text{ }^\circ\text{C}$ ;
- if in Heating mode T1  $\rangle T_{set} - 2 \text{ }^\circ\text{C}$ ;
- if the unit receives an OFF command;
- if an alarm blocks the supply ventilation;
- if ECO mode is enabled.

## Eco Mode

The air flow supply remains constant at varied heat loads and is shutdown when setpoint is fulfilled.

To further increase the energy savings in this condition, it is also possible to set less demanding operation setpoints for the unit in respect to the standard mode.

This function is indicated for the thermal maintenance of the served area in case it is temporarily not used, which can for example occur at night.

In ECO mode, the fresh air is not managed.

The ECO mode can be activated from menu:

- ECO and silent mode > RUNNING MODE > ECO

Example in cooling mode:

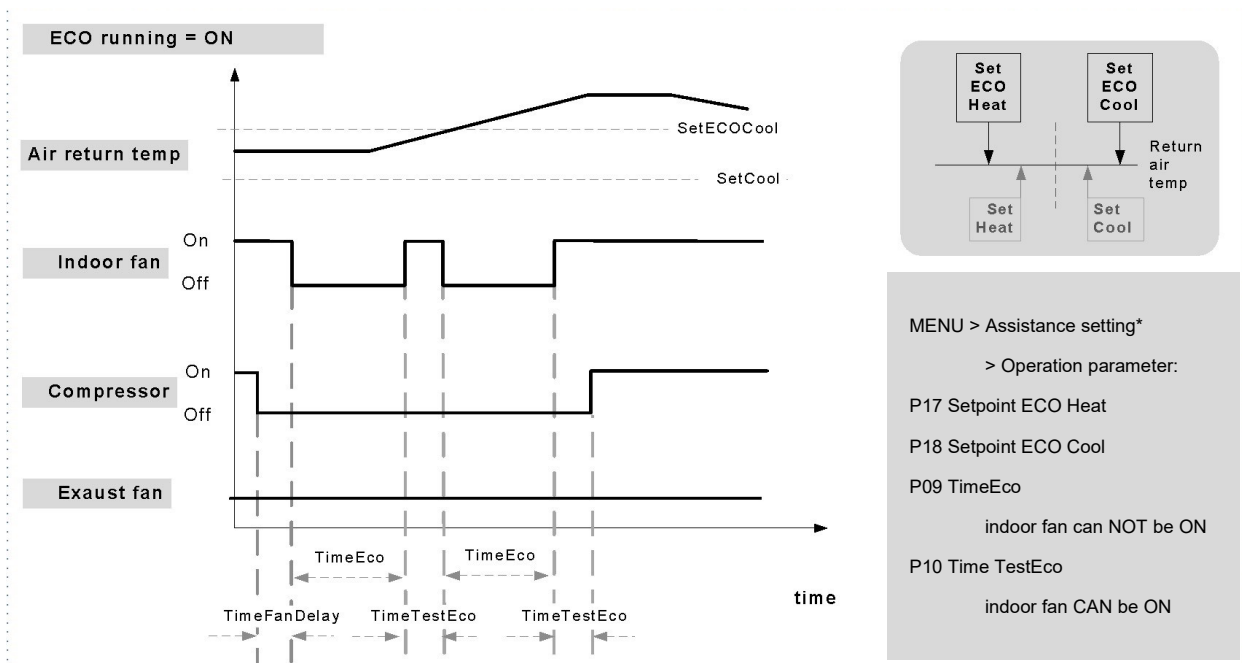

\*Assistance setting: access to password-protected menu

In ECO MODE the AUTO mode change is not available

If  $T4 \langle \text{TempAmAuxEn}$  (ASSISTANCE SETTING → OPERATION PARAMETER → P15 TempAmAuxEn (default) = 5 °C) the ECO mode is INVALID.

T4: outside air temperature

## Operating mode

The set point can be fixed (1) or variable depending on the outdoor temperature (2).

Menu: Autotemp setting

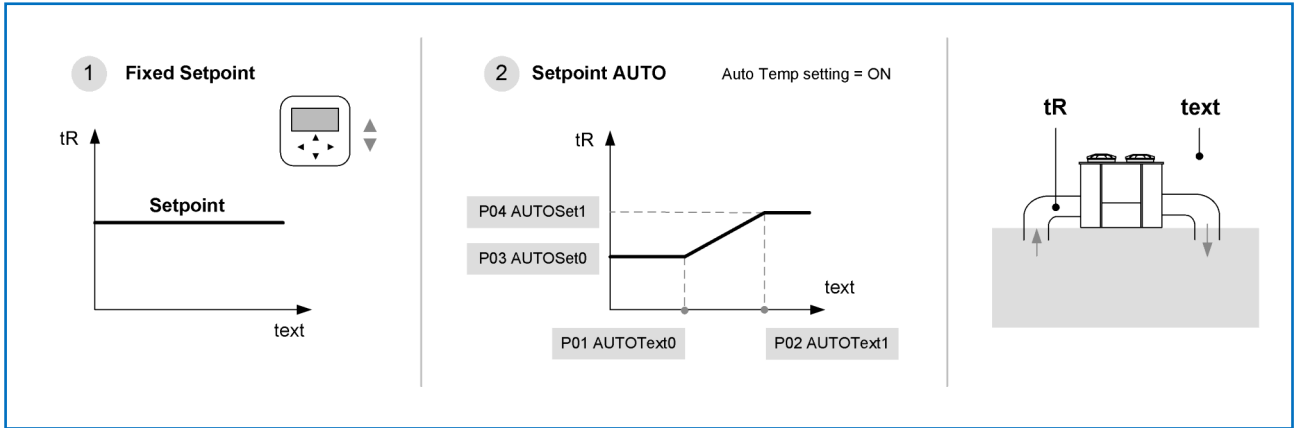

The HEAT / COOL mode can be modified:

- manually through the SA5 contact, from the keypad or through the BMS
- automatically depending on the return temperature

To choose, set P06 EnMode.

Menu > assistance setting\* > operation parameter >

\*Assistance setting: access to password-protected menu

COMBINATIONS		
P06	SET	P05 EnOnOff = 0 (Digital Input)
EnMode = 0:	D.I.	ON/OFF and MODE switch from Digital Input (SA1 / SA5)
EnMode = 1:	HMI	NOT Available
EnMode = 2:	BMS	D.I. switch (SA1) CLOSED: unit remains OFF (always) / D.I switch (SA1) OPENED: ON/OFF and MODE switch from BMS
EnMode = 3:	AUTO	ON/OFF from D.I (SA1) / AUTO CHANGEOVER

COMBINATIONS		
P06	SET	P05 EnOnOff = 1 (HMI)
EnMode = 0:	D.I.	ON/OFF from HMI / MODE switch from Digital Input (SA5)
EnMode = 1:	HMI	ON/OFF and MODE switch from HMI
EnMode = 2:	BMS	ON from HMI; OFF from HMI and BMS / MODE switch by BMS only if the rooftop is ON
EnMode = 3:	AUTO	ON/OFF from HMI / AUTO CHANGEOVER

COMBINATIONS		
P06	SET	P05 EnOnOff = 3 (BMS)
EnMode = 0:	D.I.	ON/OFF and MODE switch from BMS command
EnMode = 1:	HMI	NOT Available (the rooftop remains OFF)
EnMode = 2:	BMS	ON/OFF and MODE switch from BMS
EnMode = 3:	AUTO	ON/OFF from BMS (Modbus Mode setting commands 1 and 2 are the same) / AUTO CHANGEOVER

It is therefore possible to choose between 4 types of operation.

For all types, the transition from Heating to Cooling and vice versa is only possible if at least 30 minutes of operation have elapsed since the last mode change.

### 1 Fixed set point - Manual mode

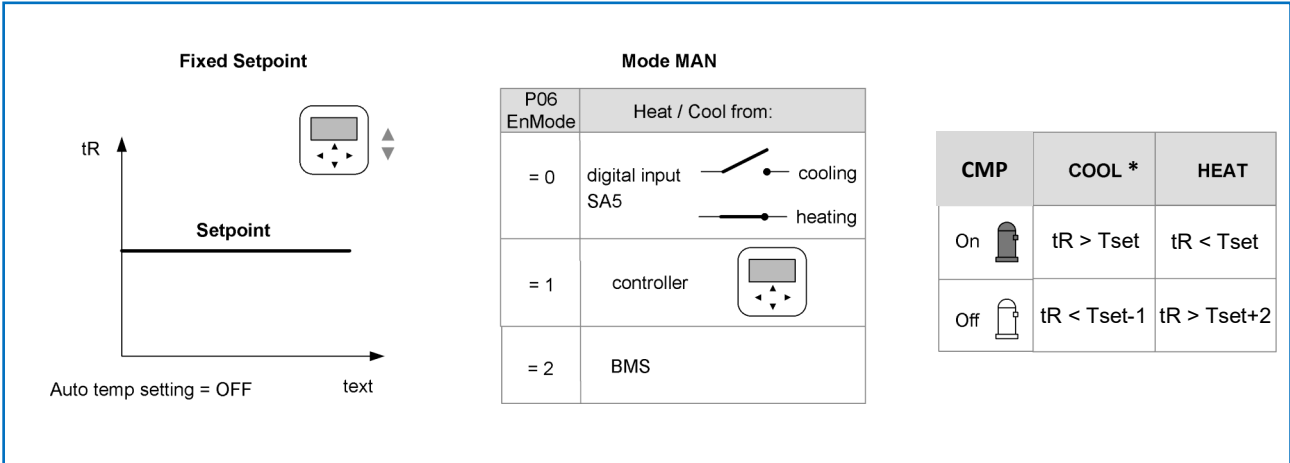

\* if humidity control (dehumidification) is not present

### 2 FIXED set point - AUTOMATIC mode

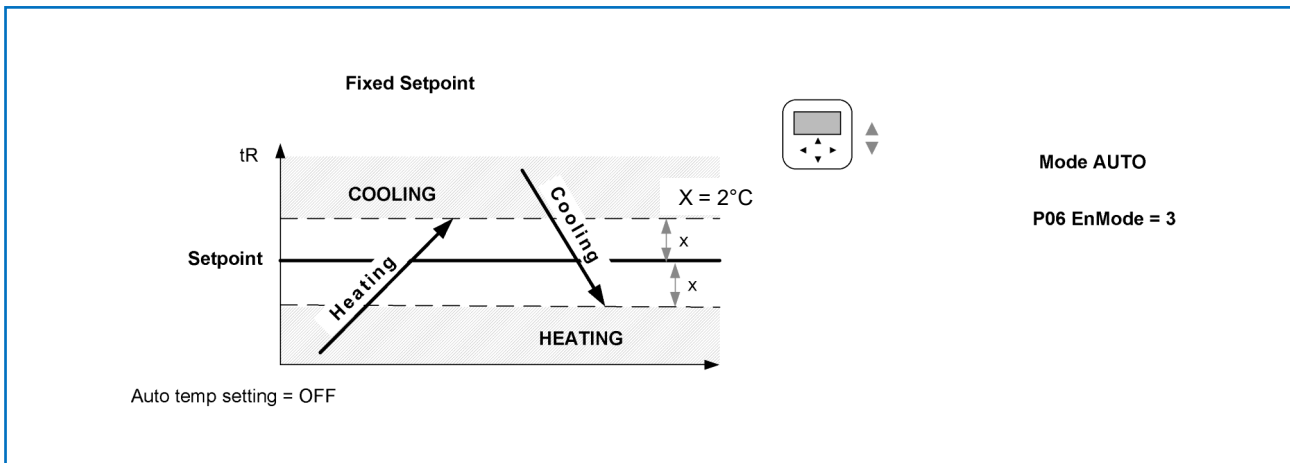

### 3 VARIABLE set point - MANUAL mode

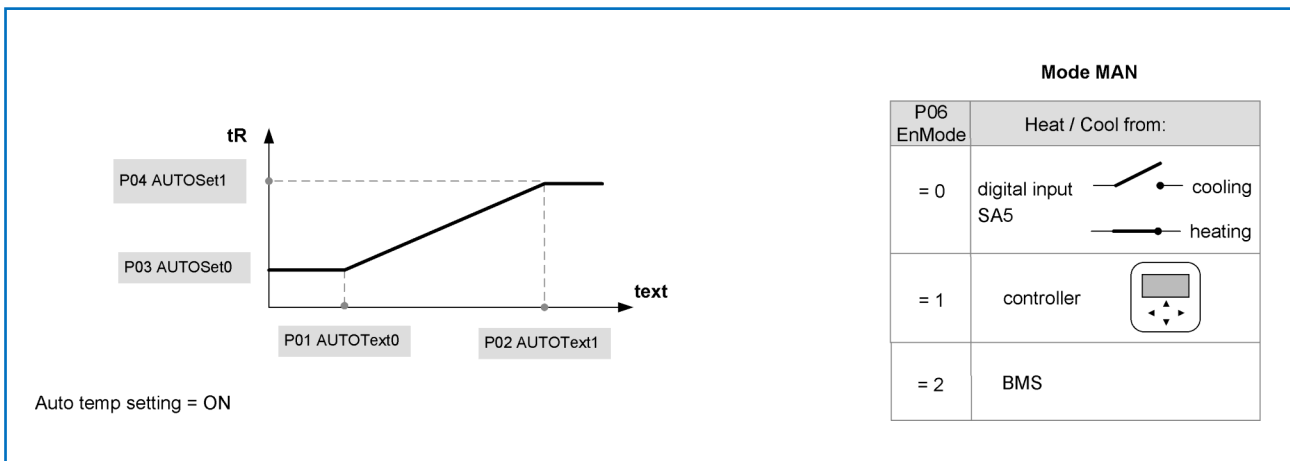

4 AUTOMATIC set point - AUTOMATIC mode

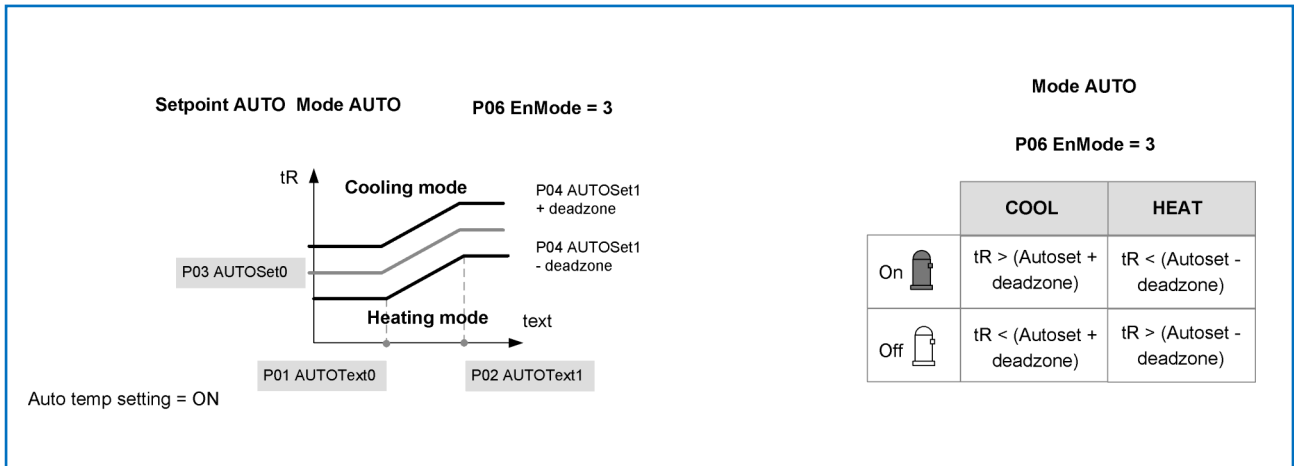

## Fire alarm: configuration

It is possible to configure the unit behaviour in presence of alarm signal.

### Par 11 TypeFireMode

MENU > Assistance setting\* > operation parameter > P11  
TypeFireMode

\*Assistance setting: access to password-protected menu

⇒ *The unit cannot be used as smoke extractor.*

⇒ *Any fire detection devices built-in the unit must be considered as an auxiliary safety system, and, accordingly, must not be a replacement for any fire detection devices in the room.*

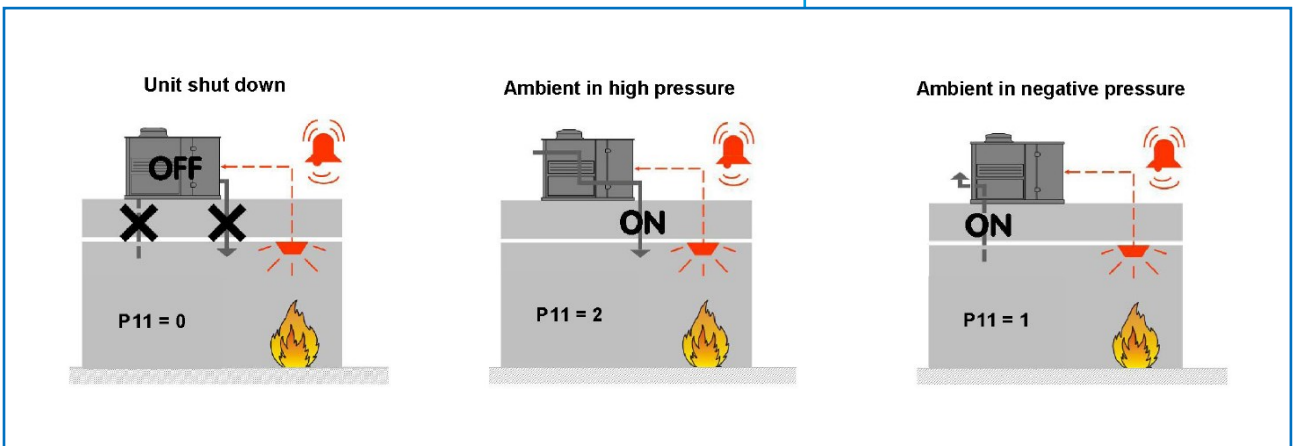

	complete stop	room kept pressurised	room kept in depression
supply fan	off	on	off
exhaust fan (1)	off	off	on
Fresh air dumper (2)	closed	open	closed

(1) CCK-REVO

(2) only for units equipped with motorized damper

## Room pressure calibration

### Only CCK-REVO configuration

The ambient pressure control device compares the return pressure with the external one and compensates for any variations by acting on the external air damper.

The unit thus maintains the environment at the relative pressure desired by the user who can choose between overpressure, depression or equi-pressure.

- 1 check the doors and windows of the serviced room are closed
- 2 the calibration must be carried out with the unit in full recirculation, with the expulsion fan stopped and with the air filters clean and at the nominal supplied air flow rate; if the unit is configured as PVAR (variable air flow) make sure that the air flow is constant and at nominal value (QSetMandV) before starting the calibration
- 3 view the status on the display: Pf2 RETURN AIR PRE
- 4 wait for the pressure value to stabilise and take note of the value
- 5 to keep the room at neutral pressure, memorise the value of the read pressure in p07 SetPAmb
- 6 to maintain the room in overpressure, memorise a lower value respect to that detected
- 7 to maintain the room in depression, memorise a higher value

Menu > Assistance setting > Exhaust Fan /Damper > P07 SetPAmb

\*Assistance setting: access to password-protected menu

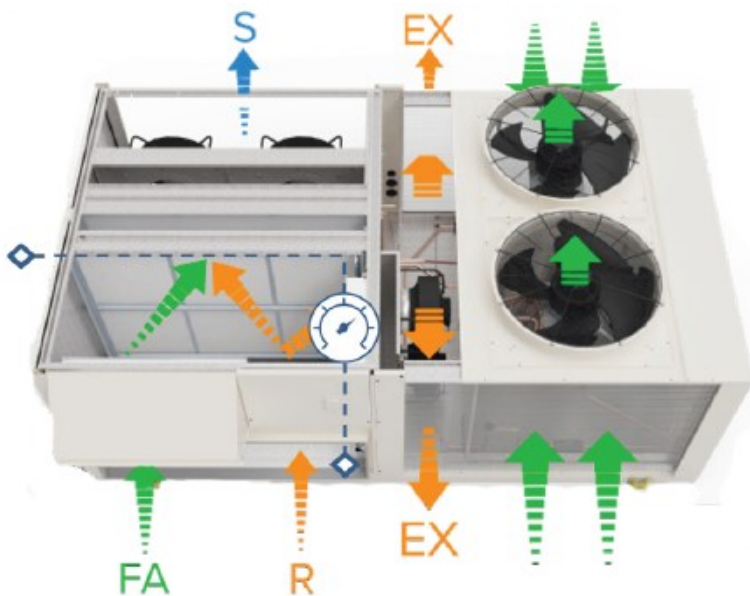

### Application in spaces with forced air exhaust at variable flow and exhaust section

Option indicated for CCKP-REVO configuration, for conditioning buildings with hoods or active air exhaust systems, for example catering kitchens, labs with suction hoods, where the fresh airflow is variable in function of the number of active extractors.

The option involves an electronic device installed built-in the unit that receives the activation status of the extractors on appropriate potential-free contacts or one 4-20mA signal and modulates the fresh air quantity. The unit is equipped with an exhaust fan section to allow air renewal even with the hoods off. The exhaust section is equipped with a plug-fan fan electronically controlled and managed by the unit logic according to the active suction hoods and the fresh air damper opening. To dimension the unit consider as max. exhaust airflow of the hoods the 50% of the nominal airflow. The option allows to manage up to 4 ON-OFF contacts from the exhaust devices or one 0-10V signal (by Customer).

The option can be managed in 3 different ways:

- A. 4 ON-OFF contacts coming from the extraction devices
- B. a single 4-20mA signal (by the customer)
- C. from modbus register by setting a value of 0-100%

The connection cables for the 4-20mA signal or the ON-OFF state do not require shielding.

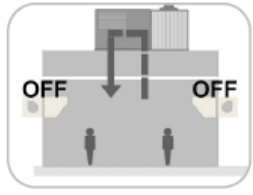
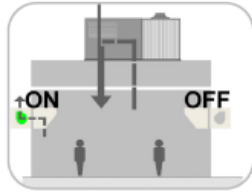
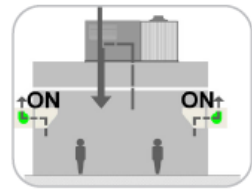
			
	Espulsione e tutti gli estrattori spenti	Espulsione e alcuni estrattori accesi	Espulsione e tutti gli estrattori accesi
	All exhaust devices OFF	Exhaust devices partially working	All exhaust devices ON
	exhaust fan = MaxFanEsp	exhaust fan = modulating from Min/MaxFanEsp	exhaust fan = MinFanEsp
A	4 contacts open	1~3 contacts open	4 contacts closed
B	4mA	4~20mA	20mA
C	0%	0%~100%	100%

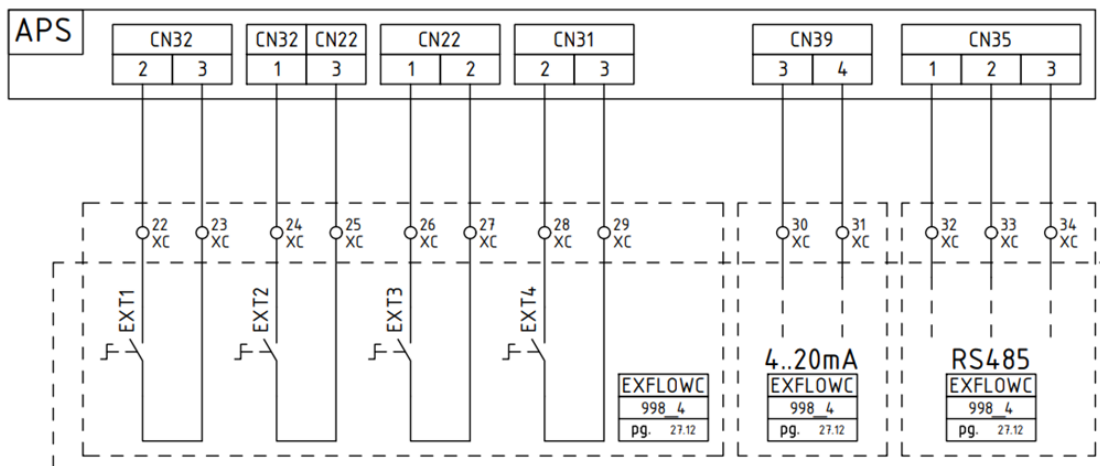

### Remote controls

Check that the remote controls (ON-OFF etc) are connected and, if necessary, enabled with the respective parameters as indicated in the “electrical connections” section.

Check that probes and optional components are connected and enabled with the respective parameters (“electrical connections” section and following pages).

### Start-up report

Identifying the operating objective conditions is useful to control the unit over time.

With unit at steady state, i.e. in stable and close-to-work conditions, identify the following data:

- total voltages and absorptions with unit at full load
- absorptions of the different electric loads (compressors, fans, pumps etc)
- temperatures and flows of the different fluids (water, air) both in input and in output from the unit
- temperature and pressures on the characteristic points of the refrigerating circuit (compressor discharge, liquid, intake)

The measurements must be kept and made available during maintenance interventions.

### 2014/68/UE PED directive

DIRECTIVE 2014/68/UE PED gives instructions for installers, users and maintenance technicians as well.

Refer to local regulations; briefly and as an example, see the following:

Compulsory verification of the first installation:

- only for units assembled on the installer’s building site (for ex. Condensing circuit + direct expansion unit)

Certification of setting in service:

- for all the units

Periodical verifications:

- to be executed with the frequency indicated by the Manufacturer (see the “maintenance inspections” paragraph)



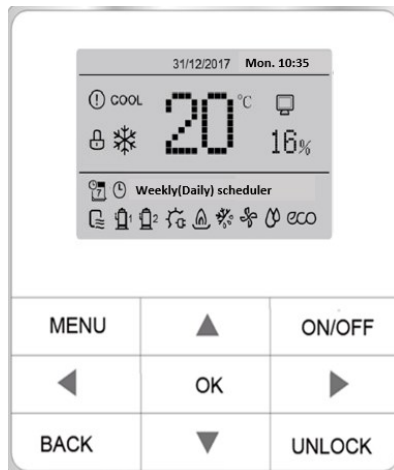

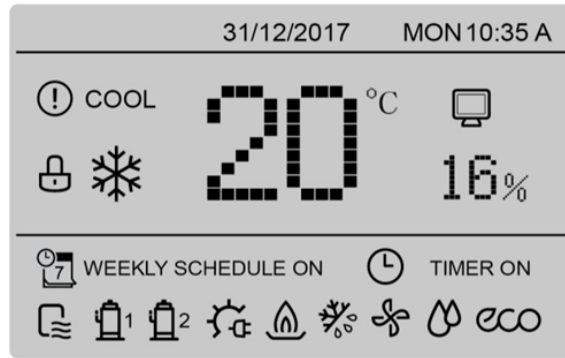

<b>MENU</b>	To open the various menus from the HOME screen.
<b>▲, ▼, ◀, ▶</b>	▲ up, ▼ down, ◀ left, ▶ right. To move the cursor, change the selection or change the set value. The parameter can be quickly changed with a long press of the button.
<b>OK</b>	To confirm an operation.
<b>ON/OFF</b>	To set the ON / OFF function.
<b>BACK</b>	To return to the previous level. Press to exit the current page and return to the previous page. Long press to return straight to the HOME screen.
<b>UNLOCK</b> (LONG PRESS)	Press and hold for more than 3 seconds to lock or unlock the buttons of the keypad. If no button on the HMI is pressed for more than 120 seconds, the keypad locks automatically. The lockout time can be set to a value between 60~240 seconds with an increment/decrement variation of ±10 seconds. Below is the procedure. MENU → INTERFACE SETTING → SCREEN LOCK TIME [s]

The wired controller must be connected to the unit.  
Otherwise, after 120 seconds the unit stops and alarm E2 is signaled.

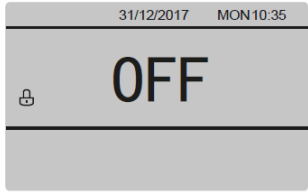
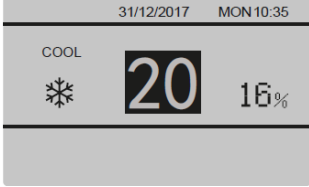

	Operating mode: indicates HEATING, COOLING and AUTOMATIC respectively.
<b>OFF</b>	It is displayed instead of the temperature (20°C) when the unit is switched off.
	Active remote control. Appears when the unit is set to be controlled by a BMS or digital input.
<b>20°</b>	Return air temperature or temperature setpoint. This area normally displays the temperature of the return air. When the set value is changed, the set temperature setpoint is displayed. When an alarm is active, the temperature is replaced by the error code. If more than one alarm is active, the display will show the last one to have been activated.
<b>16%</b>	Return air humidity value (indicator lit only when humidity control is enabled). This area normally displays the relative humidity of the return air. When the set value is changed, the set relative humidity setpoint is displayed.
	Unit status: the icon is visible when the unit is operating.
	Compressor status: the icon is visible when at least one circuit compressor is operating. The number to the right of the icon is the number of the circuit.
	Backup heater: the icon is visible when the auxiliary electric heater, water coil or single-stage or two-stage gas module is active.
	Modulating condensing gas module: the icon is visible when the gas module is operating.
	Defrosting: the icon is visible when a refrigerant circuit is defrosting the external coil.
	Supply fan: the icon is visible when the internal supply fan is operating.
	Humidifier: the icon is visible when the humidifier is operating
	Silent/super silent mode: the icon is visible when the function is active. If the function is active, the icon is displayed in place of the ECO icon.
<b>eco</b>	Eco Mode: the icon is visible when the ECO function is active.
	Timer/scheduler: the icon is visible when a valid timer (weekly schedule) is set.
	Active alarm: the icon flashes (at 1 Hz) when a fault occurs or a protection is triggered. When an alarm is active, the last active error code appears on the HOME page.
	Key lock active: the icon is displayed when the keypad is locked and no button is pressed for more than 10 seconds. The icon flashes (at 1Hz) when the keypad of the HMI is locked and any button is pressed.

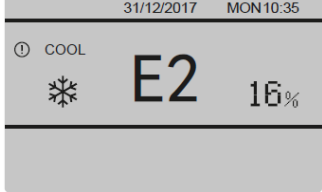
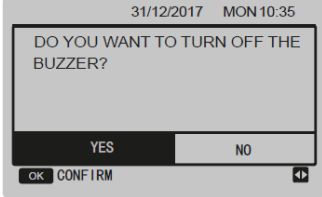
<p><b>Lock/unlock</b></p> <p>To lock/unlock the screen, press UNLOCK for 3 sec.</p> <p><b>Switch-on/off</b></p> <p>To switch it on/off, press ON/OFF.</p>	
<p><b>Temperature/humidity adjustment</b></p> <p>Press ◀ ▶ to adjust the temperature</p> <p>Press ▲ ▼ to select</p> <p>Press ◀ ▶ to adjust the temperature (if the sensor is enabled)</p> <p>Press OK to confirm</p> <p>If no operations are made for more than 10 sec, the system automatically memorises the settings and returns to the home page</p>	 
<p><b>Alarms</b></p> <p>If an alarm intervenes, the “!” symbol flashes and the error code appears.</p> <p>The beeper sounds 3 times for 180 sec.</p> <p>Press OK: the buzzer can be silenced. Select using ◀ ▶ and press OK.</p> <p style="text-align: center;"><b>Caution</b></p> <p>⇒ Before resetting an alarm identify and remove its cause.</p> <p>⇒ Repeated resets can cause irreversible damage.</p>	 

## Settings menu

Press ▲ ▼ to select each menu option.

Press OK to access the corresponding sub-menu

Press BACK to return to the home page .

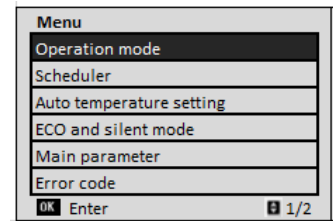

If ENMode=0 or =2 (in the ASSISTANCE menu), the mode operation is disabled

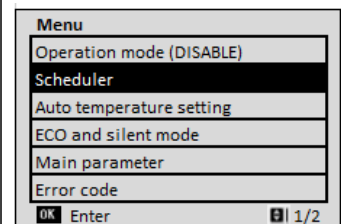

If ENMode=3 (in the ASSISTANCE menu), the mode and eco mode operations are disabled

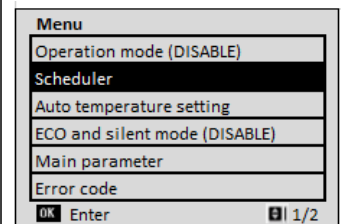

## Operating mode

Choose the mode with

▲ ▼. Confirm with OK.

After 10 sec, without any operation, the mode is memorised automatically

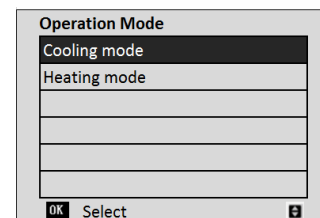
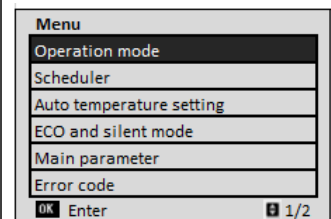

## SCHEDULER

Select SCHEDULER using ◀ ▶ and press OK.

Press ◀ ▶ to select the value of the password Press ▲ ▼ to enter the value of the password.

The password is **123** and cannot be modified.

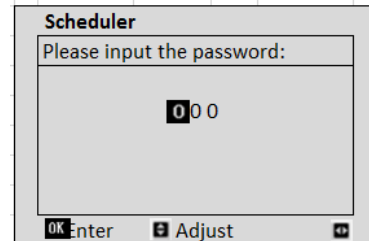
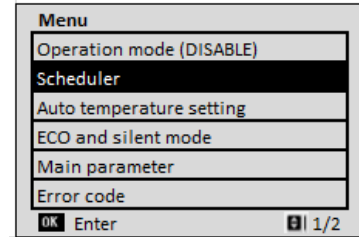

If the password is incorrect, the display will appear as follows:

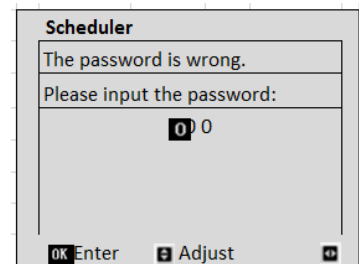

After entering the correct password, the display will appear as follows:

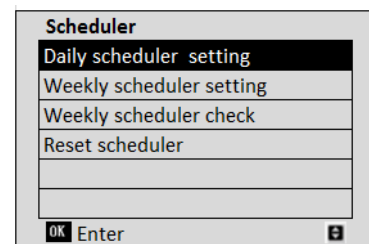

## Daily timer

Select DAILY SCHEDULER using ▲ ▼ and press OK .

If the Start time of the time band is earlier than the current time set and displayed on the HMI, the action requested in that band will be performed in the next cycle (the next day).

The screenshot shows the 'Daily scheduler' screen with a table of time bands. At the bottom, there are buttons for 'ON/OFF Select' and a back arrow.

No.	Y/N	SL	SSL	ECO	Set	Start	End
T1	<input type="checkbox"/>	<input type="checkbox"/>	<input type="checkbox"/>	<input type="checkbox"/>	26°C	00:00	00:00
T2	<input type="checkbox"/>	<input type="checkbox"/>	<input type="checkbox"/>	<input type="checkbox"/>	24°C	00:00	00:00
T3	<input type="checkbox"/>	<input type="checkbox"/>	<input type="checkbox"/>	<input type="checkbox"/>	24°C	00:00	00:00
T4	<input type="checkbox"/>	<input type="checkbox"/>	<input type="checkbox"/>	<input type="checkbox"/>	24°C	00:00	00:00
T5	<input type="checkbox"/>	<input type="checkbox"/>	<input type="checkbox"/>	<input type="checkbox"/>	24°C	00:00	00:00

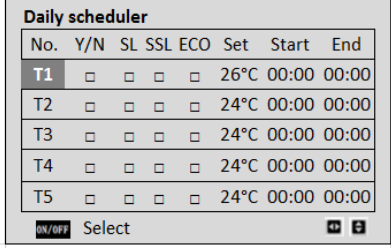
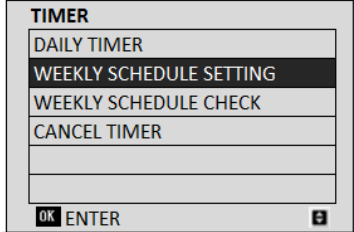
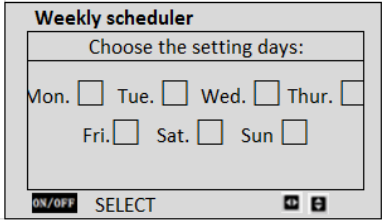
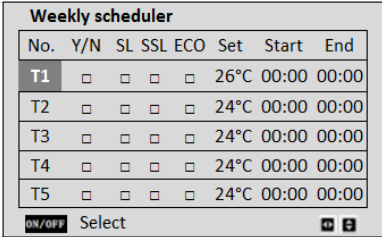
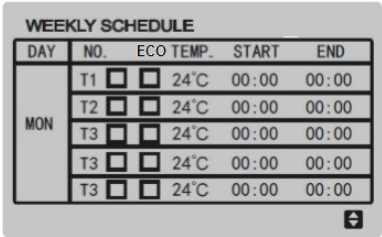
<p>Press ▲ ▼ to choose timer T1 - T5.                  Press ON/OFF to enable/disable the selected timer.                  Press ▲ ▼ to select each option to be set                  Press ▲ ▼ to adjust the temperature and start/end time parameters.                  Press OK to confirm the setting and return to the previous page, or press BACK to delete the setting and return to the previous page .</p>	
<p><b>Weekly schedule</b>                  Select WEEKLY SCHEDULE using ▲ ▼ and press OK</p>	
<p>Press ◀ ▶ ▲ ▼ to select the days.                  Press ON/OFF to confirm/delete the selected days                  After the selection, press OK to view the next page</p>	
<p>Press ▲ ▼ to choose timer T1 - T5.                  Press ON/OFF to enable/disable the selected timer.                  Press ON/OFF to enable/disable ECO function                  Press ▲ ▼ to select each option to be set                  Press ▲ ▼ to adjust the temperature and start/end time parameters.                  Press OK to confirm the setting and return to the previous page,                  or press BACK to delete the setting and return to the previous page.</p>	
<p><b>Verification of the weekly schedule</b>                  Select WEEKLY SCHEDULE CHECK in the TIMER menu                  The WEEKLY CHECK allows for viewing, but not modifying, the weekly schedule.                  Press ▲ ▼ to shift from one day of the week to another.</p>	

### Verification of the weekly schedule

Select CANCEL TIMER in the TIMER menu  
 Press ◀ ▶ to select YES.  
 Press OK to cancel all the settings of the daily and weekly timers.

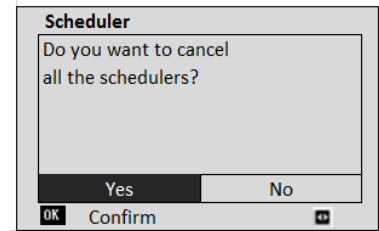

### AUTOMATIC TEMPERATURE

Press ON/OFF to enable/disable the function.  
 Press OK to confirm or BACK to cancel the operation and return to the previous page .

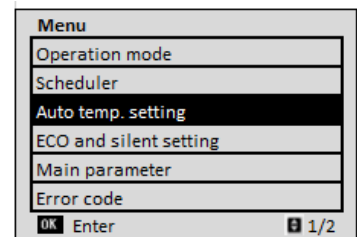

When AUTO TEMP. SETTING = ON, manual adjustment of the temperature is disabled.  
 Shown to the side is the page that appears when the user attempts to modify the temperature manually.  
 Press ◀ ▶ to select YES.  
 Press OK to disable the AUTO TEMP. function and return to the previous page

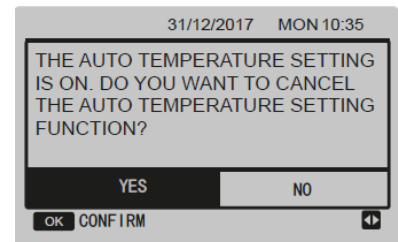

### ECO

When ECO MODE is set to ECO, the unit operates in the energy saving mode..

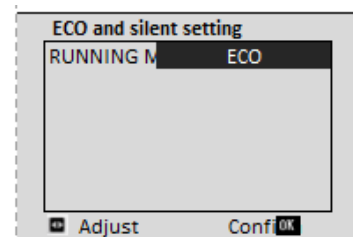
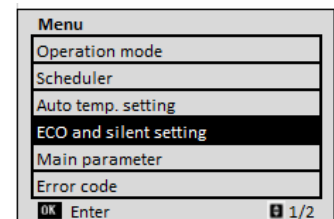

When RUNNING is set to ECO, the set point cannot be modified from the HOME page; if the user attempts to modify it, the following page appears:  
 If YES is selected, the ECO MODE function is disabled; if NO is selected, ECO MODE is still active .

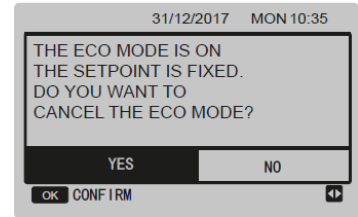

**Silent setting**

It is also possible to set the noise level.

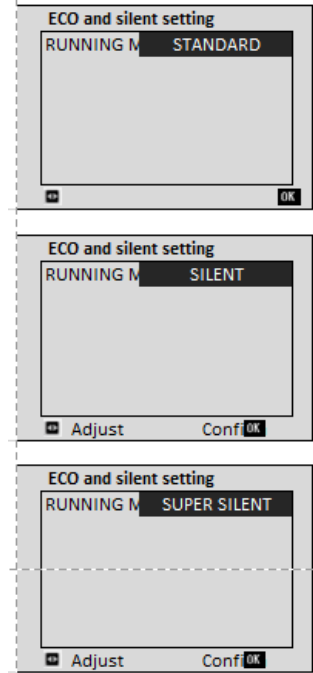

**MAIN PARAMETERS**

Press ▲ ▼ to select the parameter.

Press ◀ ▶ to set the value.

Press OK to confirm the value or press BACK to cancel it and return to the previous page.

If EnURCool = 0 and EnURHeat = 0 are set on the controller, SetUR is disabled; SetUR and URin are displayed as "--".

If EnDiffMand = 0 is set on the controller, QSetMand is disabled; QSetMand and QAir are displayed as "--".

If EnProbeCO2 = 0 is set on the controller, SetCO2 is disabled; SetCO2 and VOC are displayed as "--".

If the sensor does not work, the current value is displayed as "--".

Tc = Unit supplied air temperature

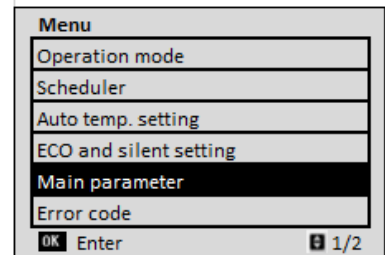

Main parameter	
Ts - Set temperature	20°C
T1 - Return temperature	25°C
SetUR - Set humidity	55%
Urin - Return humidity	55%
QSetMand - Set airflow	3200m3/h
Qair - Airflow	3200m3/h
Adjust 1/3	

Main parameter	
SetCO2	900PPM
CO2	900PPM
Tc - Supply temperature	25°C
AirPurificationOnceEn	--
T1.1 - Return temperatu	25°C
Urin.1 - Indoor humidit	55%
Adjust 1/3	

Main parameter	
T1.2 - Return temperature	25°C
Urin.2 - Indoor humidity	55%
T1.3 - Return temperature	25°C
Urin.3 - Indoor humidity	55%
T1.4 - Return temperature	25°C
Urin.4 - Indoor humidity	55%
Adjust 3/3	



## ALARM LOG

Press ▲ ▼ to select ERROR CODE.

The time of the error code is that at which the corresponding protection device intervenes or the error occurs.

Press ▲ ▼ to skip to the log pages.

Up to maximum 24 errors can be displayed (when 25 faults occur or protection devices intervene, the error that occurs first will be cancelled)

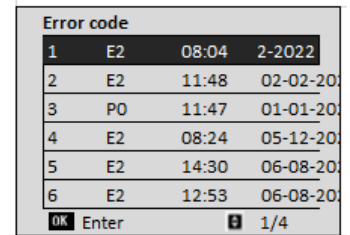
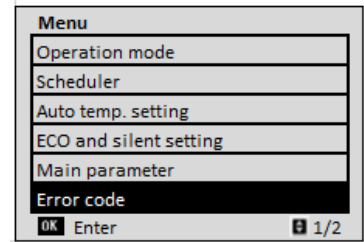

Select an error code and press OK to access the page with the details.

If an error occurs, the same page appears

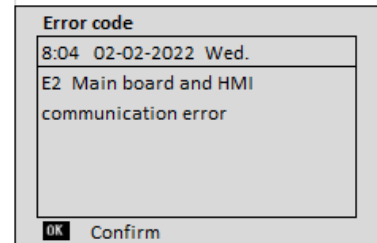

## HMI SETTINGS

It is possible to configure backlighting, buzzer, language, date and time.

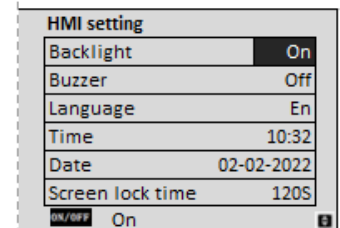
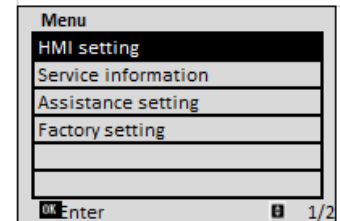

## 10 - CONTROL

Code	Description	Reset	Note
1E0	Main board EPROM fault	A	
2E0	Slave board EPROM fault	A	
E2	Communication error between the main board and the keypad/controller	A	(1)
xE3	Internal exchanger temperature probe T2-1, T2-2 fault	A	
E4	Failure of the antifreeze temperature probe Tw of the water integration coil	A	
xE5	T3_1 or T3_2 temperature probe fault: external exchanger outlet pipe (in cooling)	A	
E6	Return air temperature probe T1 fault	A	
E7	External air temperature probe failure T4	A	
E8	Power supply phase monitor alarm (controlled by phase monitor in the electrical panel)	A	
E9	Compressor type error	M	
EC	TC supply air temperature probe failure	A	
xEd.y	Compressor discharge temperature probe fault TP1-1, TP1-2, TP2-1, TP2-2	A	
EP	Fire alarm	M	
EA	Refrigerant gas leak alarm (displayed on HMI and Main PCB of the unit)	M	
EA	HMI temperature probe alarm (displayed only on HMI)	M	
EU	supply fan alarm / door safety micro	M	
xP0.y	High compressor discharge temperature or high pressure protection (pressure switch)	A/M	(2)
xP1	Low pressure circuit 1 or 2 (pressure switch)	A/M	(2)
xP4.y	High compressor current	A/M	(2)
P6	Compressor module fault L0 ~ L9 (available on the Main PCB display)	A	(2)
xP7	High temperature protection of condenser outlet pipe T3_1 or T3_2 in cooling mode	A/M	(2)
xP9.y	DC source fan protection	M	
Pb	Water coil antifreeze protection determined by Tw probe	A	
xPE	T2 probe temperature too low in Cooling mode	A	
xPF	T2 probe temperature too high in Heating mode	A	
xPL.y	Compressor inverter high temperature protection TF1_1 or TF2_1	A/M	(2)
xH0.y	Communication error between compressor inverter module and main board	A	
H1	Unit power supply high or low voltage protection	A	
xH4	P6 alarm occurred 3 times in 60 minutes	M	

A = automatic reset alarm

M = manual reset alarm

A/M = it automatically resets for "N" interventions, after which it requires manual reset

X = 1 cooling circuit N.1 or System A

2 cooling circuit N.2 or System B

Y = 1 compressor or fan N.1

2 compressor or fan N.2

(1) E2, if it persists for more than 120 seconds, stops the unit

(2) The alarm becomes a manual reset if it occurs 10 times in 120 minutes

(3) Alarm visible only on the Main PCB display. The HMI wired control will display generic code P6

Code	Description	Reset	Note
xH9.y	Alarm P9 occurred 10 times in 120 minutes	M	
xHE	EXV electronic expansion valve disconnection alarm for circuit 1 or 2	A	
F7	Enthalpy wheel protection	M	
F8	Expulsion fan protection	A	
C0	High temperature alarm for integration electric heaters	M	
C1	Humidifier alarm	A	
C2	Faulty constant pressure transducer in supply duct	A	
C3	Dirty filters alarm from air differential pressure switch	A	
C4	Electrostatic filters alarm	M	
C5	Supply air relative humidity probe Us failure	A	
C6	Intake air relative humidity probe URin fault	A	
C7	External air relative humidity probe URoutf ault	A	
C8	Supply fan differential pressure transducer Pf1 failure	A	
C9	Return / outside air differential pressure transducer Pf2 fault	A	
CA	CO2 or CO2-VOC air quality probe failure	A	
xL0.y	Compressor inverter protection	A	(3)
xL1.y	Low DC voltage inverter compressor protection		
xL2.y	High DC voltage inverter compressor protection		
xL4.y	Compressor inverter MCE failure		
xL5.y	Zero speed compressor protection		
xL7.y	Phase loss from inverter module to compressor		
xL8.y	The variation of the compressor frequency is greater than 15Hz		
xL9.y	The compressor frequency variation is 15Hz		
HP	Energy meter error	A	
HA	Communication error between remote temperature and humidity probe and main board	A	
A4	Communication protocol version between master and slave boards does not match	M	

- A = automatic reset alarm
- M = manual reset alarm
- A/M = it automatically resets for "N" interventions, after which it requires manual reset
- X = 1 cooling circuit N.1 or System A  
2 cooling circuit N.2 or System B
- Y = 1 compressor or fan N.1  
2 compressor or fan N.2
- (1) E2, if it persists for more than 120 seconds, stops the unit
- (2) The alarm becomes a manual reset if it occurs 10 times in 120 minutes
- (3) Alarm visible only on the Main PCB display. The HMI wired control will display generic code P6

## 10 - CONTROL

Pag. Menu	Num.	Name	Note	Unit of measure / value
1	1	Operation mode		OFF / COOL / HEAT / AUTO
	2	C1.1 current		A
	3	C1.1 frequency		Hz
	4	C1.2 current	40.4 & 56.4 only	A
	5	C1.2 frequency	40.4 & 56.4 only	Hz
	6	C2.1 current		A
2	7	C2.1 frequency		Hz
	8	C2.2 current	40.4 & 56.4 only	A
	9	C2.2 frequency	40.4 & 56.4 only	Hz
	10	Circuit 1 operating time	Circuit operating time saved on the HMI	h
	11	Circuit 2 operating time	Circuit operating time saved on the HMI	h
	12	Circuit 1 start times	Number of circuit starts saved on the HMI	--
3	13	Circuit 2 start times	Number of circuit starts saved on the HMI	--
	14	EXV1	Opening degree (0~480) of expansion valve	P
	15	EXV2	Opening degree (0~480) of expansion valve	P
	16	Outdoor fan 1 speed		r/min
	17	Outdoor fan 2 speed		r/min
	18	Indoor fan output		%
4	19	Indoor airflow	Supply airflow	m3/h
	20	Exhaust fan output		%
	21	Damper output	% modulating fresh air damper	%
	22	Aux-heater	Backup heater demand ON/OFF	ON/OFF
	23	Aux-heater output	Modulating backup heater demand	%
	24	Humidifier output		%
5	25	T1 – Return air temp.	Room return air temperature	°C
	26	Tc – Supply air temp.	Room supply air temperature	°C
	27	T2_1 - Indoor coil temp.	Internal coil intermediate temperature	°C
	28	T2_2 - Indoor coil temp.	Internal coil intermediate temperature	°C
	29	T2B_1 - Indoor coil temp.	Not present	°C
	30	T2B_2 - Indoor coil temp.		°C
6	31	T3_1 - Outdoor coil temp.	Temperature of condenser outlet pipe (cooling)	°C
	32	T3_2 - Outdoor coil temp.	Temperature of condenser outlet pipe (cooling)	°C
	33	T4 - Outdoor temp.	Outdoor air temperature	°C
	34	TP1_1 – Discharge temp.	Compressor discharge temperature	°C
	35	TP1_2 – Discharge temp.	Compressor discharge temperature (40.4 & 56.4 only)	°C
	36	TP2_1 – Discharge temp.	Compressor discharge temperature	°C
7	37	TP2_2 – Discharge temp.	Compressor discharge temperature (40.4 & 56.4 only)	°C
	38	TF1_1 – Inverter temp.	Compressor module temperature	°C
	39	TF1_2 – Inverter temp.	Compressor module temperature (40.4 & 56.4 only)	°C
	40	TF2_1 – Inverter temp.	Compressor module temperature	°C
	41	TF2_2 – Inverter temp.	Compressor module temperature (40.4 & 56.4 only)	°C
	42	Tw - Water coil temp.	Integration coil water temperature	°C

## 10 - CONTROL

Pag. Menu	Num.	Name	Note	Unit of measure / value
8	43	Pf1 – Indoor fan pres.	Supply airflow probe	Pa
	44	Pf2 – Return air pres.	Ambient pressure control probe	Pa
	45	Pf3 – Constant pres.	Supply constant pressure control probe	Pa
	46	URin – Return hum.	Relative humidity of room return air	%
	47	URout – Outdoor hum.	Relative humidity of outdoor air	%
	48	URs – Supply hum.	Relative humidity of supply air	%
9	49	CO2	CO2 or CO2+VOC value	PPM
	50	Power limit	% Demand Limit active	%
	51	SV1_1	Hot gas post-heating solenoid valve	ON/OFF
	52	SV1_2	Hot gas post-heating solenoid valve	ON/OFF
	53	BMS address	Unit's Modbus address	--
	54	Capacity		kW
10	55	Sensible Capacity		kW
	56	L1 Voltage		V
	57	L2 Voltage		V
	58	L3 Voltage		V
	59	L1 Current		A
	60	L2 Current		A
11	61	L3 Current		A
	62	Active power		kW
	63	Reactive power		kvar
	64	Apparent power		kVA
	65	Power factor		--
	66	Power consumption		kWh
12	67	HMI software		DATE / VERSION
	68	Main software		DATE / VERSION
	69	EEPROM software		VERSION

## SERVICE INFORMATION

Select SERVICE INFORMATION

To shift the cursor, press ▲ ▼

<p><b>Service information</b></p> <table border="1"> <tr><td>Operation mode</td><td>Cool</td></tr> <tr><td>C1.1 current</td><td>19A</td></tr> <tr><td>C1.1 frequency</td><td>103HZ</td></tr> <tr><td>C1.2 current</td><td>18A</td></tr> <tr><td>C1.2 frequency</td><td>101HZ</td></tr> <tr><td>C2.1 current</td><td>19A</td></tr> </table> <p>1/12 </p>	Operation mode	Cool	C1.1 current	19A	C1.1 frequency	103HZ	C1.2 current	18A	C1.2 frequency	101HZ	C2.1 current	19A	<p><b>Service information</b></p> <table border="1"> <tr><td>C2.1 frequency</td><td>103HZ</td></tr> <tr><td>C2.2 current</td><td>18A</td></tr> <tr><td>C2.2 frequency</td><td>101HZ</td></tr> <tr><td>Circuit 1 running time</td><td>8hours</td></tr> <tr><td>Circuit 2 running time</td><td>8hours</td></tr> <tr><td>Circuit 1 start times</td><td>9</td></tr> </table> <p>2/12 </p>	C2.1 frequency	103HZ	C2.2 current	18A	C2.2 frequency	101HZ	Circuit 1 running time	8hours	Circuit 2 running time	8hours	Circuit 1 start times	9	<p><b>Service information</b></p> <table border="1"> <tr><td>Circuit 2 start times</td><td></td></tr> <tr><td>EXV1</td><td>144</td></tr> <tr><td>EXV2</td><td>144</td></tr> <tr><td>Outdoor fan1 speed</td><td>0r/min</td></tr> <tr><td>Outdoor fan2 speed</td><td>0r/min</td></tr> <tr><td>Indoor fan output</td><td>70%</td></tr> </table> <p>3/12 </p>	Circuit 2 start times		EXV1	144	EXV2	144	Outdoor fan1 speed	0r/min	Outdoor fan2 speed	0r/min	Indoor fan output	70%			
Operation mode	Cool																																								
C1.1 current	19A																																								
C1.1 frequency	103HZ																																								
C1.2 current	18A																																								
C1.2 frequency	101HZ																																								
C2.1 current	19A																																								
C2.1 frequency	103HZ																																								
C2.2 current	18A																																								
C2.2 frequency	101HZ																																								
Circuit 1 running time	8hours																																								
Circuit 2 running time	8hours																																								
Circuit 1 start times	9																																								
Circuit 2 start times																																									
EXV1	144																																								
EXV2	144																																								
Outdoor fan1 speed	0r/min																																								
Outdoor fan2 speed	0r/min																																								
Indoor fan output	70%																																								
<p><b>Service information</b></p> <table border="1"> <tr><td>Indoor airflow</td><td>0m3/h</td></tr> <tr><td>Exhaust fan output</td><td>0%</td></tr> <tr><td>Damper output</td><td>0%</td></tr> <tr><td>Aux-heater</td><td>OFF</td></tr> <tr><td>Aux-heater output</td><td>0%</td></tr> <tr><td>Humidifier output</td><td>0%</td></tr> </table> <p>4/12 </p>	Indoor airflow	0m3/h	Exhaust fan output	0%	Damper output	0%	Aux-heater	OFF	Aux-heater output	0%	Humidifier output	0%	<p><b>Service information</b></p> <table border="1"> <tr><td>T1 -Return ait temp.</td><td>25°C</td></tr> <tr><td>Tc-Supply air temp.</td><td>25°C</td></tr> <tr><td>T2_1-Indoor coil temp.</td><td>25°C</td></tr> <tr><td>T2_1-Indoor coil temp.</td><td>25°C</td></tr> <tr><td>T2B_1-Indoor coil temp.</td><td>25°C</td></tr> <tr><td>T2B_1-Indoor coil temp.</td><td>25°C</td></tr> </table> <p>5/12 </p>	T1 -Return ait temp.	25°C	Tc-Supply air temp.	25°C	T2_1-Indoor coil temp.	25°C	T2_1-Indoor coil temp.	25°C	T2B_1-Indoor coil temp.	25°C	T2B_1-Indoor coil temp.	25°C	<p><b>Service information</b></p> <table border="1"> <tr><td>T3_1-Outdoor coil temp.</td><td>25°C</td></tr> <tr><td>T321-Outdoor coil temp.</td><td>25°C</td></tr> <tr><td>T4-Outdoor temp.</td><td>20°C</td></tr> <tr><td>TP1_1-Discharge temp.</td><td>25°C</td></tr> <tr><td>TP1_2-Discharge temp.</td><td>25°C</td></tr> <tr><td>TP2_1-Discharge temp.</td><td>25°C</td></tr> </table> <p>6/12 </p>	T3_1-Outdoor coil temp.	25°C	T321-Outdoor coil temp.	25°C	T4-Outdoor temp.	20°C	TP1_1-Discharge temp.	25°C	TP1_2-Discharge temp.	25°C	TP2_1-Discharge temp.	25°C			
Indoor airflow	0m3/h																																								
Exhaust fan output	0%																																								
Damper output	0%																																								
Aux-heater	OFF																																								
Aux-heater output	0%																																								
Humidifier output	0%																																								
T1 -Return ait temp.	25°C																																								
Tc-Supply air temp.	25°C																																								
T2_1-Indoor coil temp.	25°C																																								
T2_1-Indoor coil temp.	25°C																																								
T2B_1-Indoor coil temp.	25°C																																								
T2B_1-Indoor coil temp.	25°C																																								
T3_1-Outdoor coil temp.	25°C																																								
T321-Outdoor coil temp.	25°C																																								
T4-Outdoor temp.	20°C																																								
TP1_1-Discharge temp.	25°C																																								
TP1_2-Discharge temp.	25°C																																								
TP2_1-Discharge temp.	25°C																																								
<p><b>Service information</b></p> <table border="1"> <tr><td>TP2_2-Discharge temp.</td><td>25°C</td></tr> <tr><td>TF1_1-Inverter temp.</td><td>0°C</td></tr> <tr><td>TF1_2-Inverter temp.</td><td>0°C</td></tr> <tr><td>TF2_1-Inverter temp.</td><td>0°C</td></tr> <tr><td>TF2_2-Inverter temp.</td><td>0°C</td></tr> <tr><td>Tw-water coil temp.</td><td>--</td></tr> </table> <p>7/12 </p>	TP2_2-Discharge temp.	25°C	TF1_1-Inverter temp.	0°C	TF1_2-Inverter temp.	0°C	TF2_1-Inverter temp.	0°C	TF2_2-Inverter temp.	0°C	Tw-water coil temp.	--	<p><b>Service information</b></p> <table border="1"> <tr><td>Pf1-Indoor fan pres.</td><td>--</td></tr> <tr><td>Pf2-Indoor fan pres.</td><td>--</td></tr> <tr><td>Pf3-Constant pres.</td><td>--</td></tr> <tr><td>Urin-Return hum.</td><td>--</td></tr> <tr><td>Urout-Outdoor hum.</td><td>--</td></tr> <tr><td>Urs-Supply hum.</td><td>--</td></tr> </table> <p>8/12 </p>	Pf1-Indoor fan pres.	--	Pf2-Indoor fan pres.	--	Pf3-Constant pres.	--	Urin-Return hum.	--	Urout-Outdoor hum.	--	Urs-Supply hum.	--	<p><b>Service information</b></p> <table border="1"> <tr><td>CO2</td><td>--</td></tr> <tr><td>Power limit</td><td>100%</td></tr> <tr><td>SV1_1</td><td>OFF</td></tr> <tr><td>SV1_2</td><td>OFF</td></tr> <tr><td>BMS address</td><td>1</td></tr> <tr><td>Capacity</td><td>0kW</td></tr> </table> <p>9/12 </p>	CO2	--	Power limit	100%	SV1_1	OFF	SV1_2	OFF	BMS address	1	Capacity	0kW			
TP2_2-Discharge temp.	25°C																																								
TF1_1-Inverter temp.	0°C																																								
TF1_2-Inverter temp.	0°C																																								
TF2_1-Inverter temp.	0°C																																								
TF2_2-Inverter temp.	0°C																																								
Tw-water coil temp.	--																																								
Pf1-Indoor fan pres.	--																																								
Pf2-Indoor fan pres.	--																																								
Pf3-Constant pres.	--																																								
Urin-Return hum.	--																																								
Urout-Outdoor hum.	--																																								
Urs-Supply hum.	--																																								
CO2	--																																								
Power limit	100%																																								
SV1_1	OFF																																								
SV1_2	OFF																																								
BMS address	1																																								
Capacity	0kW																																								
<p><b>Service information</b></p> <table border="1"> <tr><td>Sensible Capacity</td><td>0kW</td></tr> <tr><td>L1Voltage</td><td>0V</td></tr> <tr><td>L2Voltage</td><td>0V</td></tr> <tr><td>L3Voltage</td><td>0V</td></tr> <tr><td>L1Current</td><td>0A</td></tr> <tr><td>L2Current</td><td>0A</td></tr> </table> <p>10/12 </p>	Sensible Capacity	0kW	L1Voltage	0V	L2Voltage	0V	L3Voltage	0V	L1Current	0A	L2Current	0A	<p><b>Service information</b></p> <table border="1"> <tr><td>L3Current</td><td>0A</td></tr> <tr><td>ActivePower</td><td>0kW</td></tr> <tr><td>ReactivePower</td><td>0var</td></tr> <tr><td>ApparentPower</td><td>0VA</td></tr> <tr><td>PowerFactor</td><td>0</td></tr> <tr><td>Power Consume</td><td>0kWh</td></tr> </table> <p>11/12 </p>	L3Current	0A	ActivePower	0kW	ReactivePower	0var	ApparentPower	0VA	PowerFactor	0	Power Consume	0kWh	<p><b>Service information</b></p> <table border="1"> <tr><td>HMI software</td><td>23-11-22</td><td>V65</td></tr> <tr><td>Main software</td><td>15-01-23</td><td>V28</td></tr> <tr><td>EEPROM</td><td></td><td>V37</td></tr> <tr><td></td><td></td><td></td></tr> <tr><td></td><td></td><td></td></tr> </table> <p>12/12 </p>	HMI software	23-11-22	V65	Main software	15-01-23	V28	EEPROM		V37						
Sensible Capacity	0kW																																								
L1Voltage	0V																																								
L2Voltage	0V																																								
L3Voltage	0V																																								
L1Current	0A																																								
L2Current	0A																																								
L3Current	0A																																								
ActivePower	0kW																																								
ReactivePower	0var																																								
ApparentPower	0VA																																								
PowerFactor	0																																								
Power Consume	0kWh																																								
HMI software	23-11-22	V65																																							
Main software	15-01-23	V28																																							
EEPROM		V37																																							

## MODBUS

### Enabling

Menu > Assistance setting > password > operation parameter :

05 EnOnOff = 2

06 EnMode = 2

### Communication spec:RS-485

Communication Parameters *	
BaudRate	9600bps
Data Bit	8
Stop Bit	1
Parity	NONE

\*cannot be changed

### Enabling

The Modbus address can be modified by parameter P31 BMS\_Address.

Menu > Assistance setting > password > operation parameter:

P31 BMS\_Address

Function Code	
03	Read Holding Registers
06	Write Single Register
16	Write Multiple Registers

Error code		
Exception Code)		
01	Illegal function code	Unsupported function code.
02	illegal data address	The address that is sent when query or set, undefined in the online controller.
03	illegal data value	The parameters set are illegal, beyond the reasonable range or not the valid parameter for current state of the wired controller.

Accessed by 03&06&16 command for both HMI and BMS		
Addr	Data	Description
0	Unit mode Set	0: OFF 1: ON Cool 2: ON Heat
1	Temperature Set	14~28°C
2	Humidity Set	0~100%
3	Set air quantity	20.2: 8500~14000 m3/h 28.2: 13000~20500 m3/h 40.4: 17000~26000 m3/h 56.4: 22000~34000 m3/h
4	Auto Temperature Set	0:Disable 1:Enable
5	ECO mode	0:Disable 1:Enable
6	Air Quality Setpoint	100~2000 ppm
7	FollowMe_SetTemp. (1)	-25~70°C
8	DemandLimit request (2)	0~100%
9	FanSpeedOutMandBms (3)	30~100%
10	ExFlowBMS (4)	0~100%
11	Clean function	0:Disable 1:Enable
12	SilentMode	0:Disable 1:Silent 2:Super Silent

(1) It is possible to set the FollowMe Set Temp only when the FollowMe function is enabled by parameter on the HMI. This register is still accessible and writable even if the FollowMe function is not enabled but its content will not be taken into consideration and will have no effect.  
Unit:0.1°C. 0x8000: HMI temperature sensor Fault

(2) (3) (4) These functions, to be managed by BMS, must be suitably enabled by the HMI by a Clivet qualified technician



NOTE: the registers below are read only

Readable registers by Modbus function "03"		
Addr	Data	Description
200	Modbus address number of the unit	BMS address
202	Rooftop size	60: 20.2 80: 28.2 120: 40.4 160: 56.4
203	Operating mode	0 = OFF, 1 = ON Cooling, 2 = ON Heating
204	Circuit 1 operating status	0: Off 1: On
		BIT0: Unit status (lsb)
		BIT1: C1_1 status
		BIT2: C2_1 status
		BIT3: Electrical Heater status
		BIT4: Other auxiliary heater status
		BIT5: Defrost status
		BIT6: Supply fan status
		BIT7: Humidifier status
		BIT8: ECO mode status
		BIT9: circuit 1 Fault
		BIT10: circuit 1 SV1_1 status
		BIT11: circuit 2 SV1_2 status
BIT12: clean function status		
205	C1_1 operating current	Unit: A
206	C2_1 operating current	Unit: A
207	C1_1 operating frequency	Unit: Hz
208	C2_1 operating frequency	Unit: Hz
209	Circuit 1 EXV opening degree	steps
210	Circuit 1 outdoor fan speed	rpm
211	Supply fan cmd signal	%
212	Supply airflow rate	m3/h
213	Exhaust fan cmd signal	%
214	Fresh air damper cmd signal	%
215	Fault code	BIT0-BIT7-Error Code (LSB)
		BIT8-BIT11: Components ID
		BIT12-BIT15: Circuit ID
		Ex:Circuit ID=1, Components ID=3, Error code = E1, Then display:1E1.3
217	T1 Return Air Temp.	(-25~70°C), Unit:1°C
218	Tc Supplied Air Temp.	(-25~70°C), Unit:1°C
219	T2_1 inner (middle) exchanger temp. probe	(-25~70°C), Unit:1°C
220	T3_1 external (outlet pipe in cooling) exchanger temp. probe	(-25~70°C), Unit:1°C
221	T4 Outdoor Air Temp.	(-25~70°C), Unit:1°C
222	TP1_1 CMP discharge temperature	(-25~70°C), Unit:1°C
223	TP1_2 CMP discharge temperature	(-25~70°C), Unit:1°C

Accessed by 03 command for both HMI and BMS		
Addr	Data	Description
224	TF1_1 CMP inverter heatsink temperature probe	(0~140°C), Unit:1°C
225	TF2_1 CMP inverter heatsink temperature probe	(0~140°C), Unit:1°C
227	Tw Water Coil Antifreeze Temp. Probe	((0~140°C), Unit:1°C
228	Pf1 Sonda portata aria di mandata	Pa (0~2000)
229	Pf2 Ambient pressure management probe	Pa (0~2000)
230	URi Return Air R.H.%	%
231	Uro Outdoor Air R.H.%	%
232	CO2/VOC Return Air	0-2000 ppm
234	Auxiliary Heater cmd signal	%
235	Humidifier cmd signal	%
237	Pf3 differential pressure sensor for constant supply duct pressure control	Pa (0~2000)
240	Circuit 2 operating state	0: Off 1: On
		BIT0: Unit status (lsb)
		BIT1: C1_2 status
		BIT2: C2_2 status
		BIT3: reserved
		BIT4: reserved
		BIT5: Defrost status circuit 2
		BIT6: reserved
		BIT7: reserved
		BIT8: reserved
BIT9: circuit 2 Fault		
241	Circuit 2 outdoor fan speed	rpm
242	Circuit 2 EXV opening degree	steps
243	T2_2 inner (middle) exchanger temp. Probe	(-25~70°C), Unit:1°C
244	T3_2 external (outlet pipe in cooling) exchanger temp. Probe	(-25~70°C), Unit:1°C
246	TP1_2 CMP discharge temperature	(0~140°C), Unit:1°C
247	TP2_2 CMP discharge temperature	(0~140°C), Unit:1°C
248	TF1_2 CMP inverter heatsink temperature probe	(0~140°C), Unit:1°C
249	TF2_2 CMP inverter heatsink temperature probe	(0~140°C), Unit:1°C
251	C1_2 operating current	Unit: A
252	C2_2 operating current	Unit: A
253	C1_2 operating frequency	Unit: Hz
254	C2_2 operating frequency	Unit: Hz
260	History Fault code1	Last error appeared (chronologically)
		BIT0-BIT7: Error Code
		BIT8-BIT11: Components ID
		BIT12-BIT15: Circuit ID
i.e.: Circuit ID=1, Components ID=3, Error code = E1, Then display:1E1.3 for more information, check the paragraph after this table.		

Accessed by 03 command for both HMI and BMS		
Addr	Data	Description
261	History Fault code2	Error that appeared earlier than the one reported in reg. 260 *
262	History Fault code3	Error that appeared earlier than the one reported in reg. 261*
272	T1.1 Return temperature	(-25~70°C), Unit:1°C
273	URin.1 Indoor humidity	%
274	T1.2 Return temperature	(-25~70°C), Unit:1°C
275	URin.2 Indoor humidity	%
276	T1.3 Return temperature	(-25~70°C), Unit:1°C
277	URin.3 Indoor humidity	%
278	T1.4 Return temperature	(-25~70°C), Unit:1°C
279	URin.4 Indoor humidity	%
280	L1Voltage	Unit:0.01V
281	L2Voltage	Unit:0.01V
282	L3Voltage	Unit:0.01V
283	L1Current	Unit:0.001A
284	L2Current	Unit:0.001A
285	L3Current	Unit:0.001A
286	ActivePower	Unit:10W
287	ReactivePower	Unit:10var
288	ApparentPower	Unit:10VA
289	Powerfactor	
290	TotalActEnergyH	kWh
291	TotalActEnergyL	
295	URs supplied air R.H.%	%
296	Capacity	kW
297	Demand Limit Feedback	%
298	Sensible capacity	kW
400	SW version information1	High byte: year low byte: month
401	SW version information2	High byte: day low byte: version
402	Eeprom version	
403	SW version information1 for extension board	High byte: year low byte: month
404	SW version information2 for extension board	High byte: day low byte: version

\* the decoding logic is the same used for register 260

MODBUS ALARM DECODING

The rooftop has 2 refrigerant circuits.

Each refrigerant circuit can have up to 2 of the same components according to its size (i.e. 2 compressors etc.).

The Modbus register 215 displays the hexadecimal (HEX) number that corresponds to an error code listed in alarm table.

Below the rules to decode properly the HEX number:

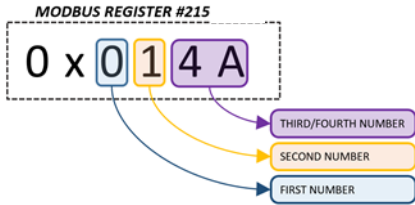

The *first number* represents the refrigerant circuit's number:  
 0 = no circuit relationship;  
 1 = circuit N.1;  
 2 = circuit N.2.

The *second number* represents the component's ID in the refrigerant circuit:

0 = no component relationship;  
 1 = component ID N.1;  
 2 = component ID N.2.

The *third and fourth number* (in the table named LSH), together, represent the error code.

Use the following table to get the codification:

Example of an HEX number read in the register #215

Alarm Code	LSH	Alarm Code	LSH	Alarm Code	LSH	Alarm Code	LSH	Alarm Code	LSH	Alarm Code	LSH
A4	5 HEX	E0	3D HEX	F7	58 HEX	H0	65 HEX	L0	79 HEX	P0	B5 HEX
		E2	3F HEX	F8	59 HEX	H1	66 HEX	L1	7A HEX	P1	B6 HEX
		E3	40 HEX			H2	67 HEX	L2	7B HEX	P4	B9 HEX
		E4	41 HEX			H4	69 HEX	L4	7D HEX	P6	BB HEX
		E5	42 HEX			H9	6E HEX	L5	7E HEX	P7	BC HEX
		E6	43 HEX			HA	6F HEX	L7	80 HEX	P9	BE HEX
		E7	44 HEX			HE	73 HEX	L8	81 HEX	Pb	CO HEX
		E8	45 HEX			HP	77 HEX	L9	82 HEX	PE	C3 HEX
		E9	46 HEX							PF	C4 HEX
		EA	47 HEX							PL	C6 HEX
		EC	49 HEX								
		Ed	4A HEX								
		EF	4C HEX								
		EP	4F HEX								
		EU	50 HEX								

<p><sup>1</sup> Example N.1: Modbus Register #215 = 0x114A                  1 = circuit N.1;                  1 = component ID N.1;                  4A = <b>Ed</b> [Tp1.1 compressor discharge temp. probe fault].</p>	<p><sup>3</sup> Example N.3: Modbus Register #215 = 0x002C                  0 = no circuit relationship;                  0 = no component ID relationship;                  2C = <b>C3</b> [Dirty Filters Alarm].</p>
<p><sup>2</sup> Example N.2: Modbus Register #215 = 0x0050                  0 = no circuit relationship;                  0 = no component relationship;                  50 = <b>EU</b> [supplied air fans alarm].</p>	<p><sup>4</sup> Example N.4: Modbus Register #215 = 0x1169                  1 = circuit N.1;                  1 = component ID N.1                  69 = <b>H4</b> [compressor N.1 - circuit N.1 - inverter module protection].</p>

### Area checks

Before working on systems containing flammable refrigerants, perform safety checks to reduce the risk of combustion to the minimum. Before performing any reparation operations on the cooling system, comply with the following warnings.

### Work procedures

Operations must be performed following a controlled procedure so as to reduce the risk of flammable gases or vapours developing.

### General work area

All the personnel in charge with maintenance operations and other operators working in the local area must be instructed and monitored as regards the nature of the intervention.

Avoid working in tight spaces. The area surrounding the working space must be cordoned off. Make sure the area is secured by monitoring the flammable material.

### Check the presence of refrigerant

Both before and during operations, the area must be monitored with a dedicated refrigerant detector to make sure the technician is aware of the presence of potentially-flammable environments.

Make sure the leak detection equipment is suitable for use with flammable refrigerants and therefore without sparks, suitably sealed or intrinsically safe.

### Presence of the fire extinguisher

If hot interventions are not performed on cooling equipment or connected components, suitable fire fighting equipment must be kept at hand.

Keep a dry-powder or CO2 extinguisher near the loading area.

### No ignition source

It is absolutely forbidden to use ignition sources that may lead to fire or explosion during operations on the cooling system or on pipes that contain or have contained flammable refrigerant.

All possible ignition sources, including cigarettes, must be kept sufficiently away from the installation, reparation, removal and disposal site as flammable refrigerant may be released in the surrounding area.

Before starting operations, the area surrounding the equipment must be inspected to guarantee the absence of flammables or combustion risks. "SMOKING IS FORBIDDEN" signs must be affixed.

### Ventilated area

Before intervening on the system or performing any hot intervention, make sure to be in an outdoor or suitably ventilated area.

Ventilation must be maintained during operations. Ventilation must disperse the released refrigerant safely, preferably outdoors in the atmosphere.

### Cooling equipment checks

Should a replacement be necessary, the new components installed must be suitable for the purpose envisaged and compliant with specifications.

Always follow the manufacturer guidelines on maintenance and assistance. In case of doubt, contact the manufacturer technical office for assistance.

The following checks must be preformed on systems containing flammable refrigerants:

- the quantity of the charge must comply with the size of the room where the parts containing refrigerant are installed;
- the machine and ventilation intake function correctly and are not obstructed;
- If an indirect cooling circuit is used, the secondary circuits must be checked to verify the presence of refrigerants; the marking on the equipment remains visible and readable;
- Make sure markings and symbols are always readable; cooling pipes or components must be installed in a position that makes improbable their exposure to substances that may corrode the components containing refrigerant, unless they are manufactured with material intrinsically resistant to corrosion or suitably protected against corrosion.

### Electrical device checks

The reparation and maintenance of electric components must include initial safety checks and component inspection procedures.

In case of a fault that compromises safety, do not perform any electrical connection to the circuit until said fault is suitably resolved.

If it is not possible to repair the fault immediately and electrical components need to remain functioning, a temporary solution must be adopted. This must be reported to the owner of the equipment so as to keep all parties informed.

Initial safety checks must include:

- that condensers are emptied. This operation must be performed safely to avoid any sparks;
- that electrical components and wiring are not exposed during the charging, recovering or venting phases;
- That the earth conductor is continuous.

### Repairing sealed components

- During the reparation operations of sealed components, disconnect all the equipment before removing sealed casings etc. If, during operations, it is absolutely necessary for the equipment to remain connected, a leak detection device must be placed in the most critical point so as to report any potentially-dangerous situation.
- Pay particular attention to what follows to guarantee that, while intervening on electrical components, the housing is not altered in a way so as to affect the level of protection. This includes damage to cables, an excessive number of connections, terminals not compliance with the original specifications, damage to gaskets, an unsuitable installation of gaskets, etc.
- Make sure the device is installed safely.
- Check that the seals or sealing materials are not altered in such a way that they no longer impede the entry of flammable environments. Spare parts must comply with manufacturer specifications.

#### NOTE:

⇒ *Using silicone sealants may inhibit the effectiveness of a few types of leak detection equipment. It is not necessary to isolate intrinsically safe components before performing operations on them.*

### Reparation of intrinsically safe components

Do not apply permanent inductive or capacitive loads to the circuit without making sure that they do not exceed the admissible voltage and current allowed for equipment in use.

Intrinsically safe components are the only component type on which operations can be performed in a flammable atmosphere. The testing device must show a correct value. Replace components only with the parts specified by the manufacturer.

Following a leak, other parts could lead to the combustion of the refrigerant in the atmosphere.

### Wires

Make sure wires are not subjected to wear, corrosion, excessive pressure or vibration, that there are no sharp edges and that they do not produce other negative effects on the environment. The inspection must also keep into consideration the effects of time or the continuous vibration caused e.g. by compressors or fans.

### Detection of flammable refrigerants

Under no circumstance is it possible to use potential ignition sources to search or detect refrigerant leaks.

Do not use halide lights (or any other open flame detectors).

### Leak detection methods

The following leak detection methods are considered acceptable for systems containing flammable refrigerants. Electric leak detectors must always be used to identify flammable refrigerants, although they do not present a suitable sensitivity level or require recalibration (detection equipment must be calibrated in an area free from refrigerants).

Check that the detector is not a possible source of ignition and that it is suitable for the refrigerant. Leak detection equipment must always be set to an LFL percentage and calibrated depending on the refrigerant used, so the correct gas percentage (25% max) must be verified.

Leak detection fluids are suitable for most refrigerants, although using detergents containing chlorine should be avoided as this substance may react with the refrigerant and corrode copper pipes.

If a leak is suspected, all open flames must be removed or switched off.

If a leak is identified that requires brazing, all the refrigerant must be recovered from the system or isolated (using interception valves) in a section of the system far away from the leak. Oxygen-Free-Nitrogen (OFN) is then purged through the system both before and during the brazing procedure.

### Removal and evacuation

When intervening on the cooling circuit to perform repair work or any other type of work, always follow the normal procedure. However, considering the risk of flammability, we recommend following the best practices. Comply with the following procedure:

- remove the refrigerant;
- purge the circuit with inert gas;
- evacuate;
- Purge again with inert gas;
- Interrupt the circuit with interruption or brazing.

The refrigerant charge must be collected in suitable recovery tanks. To make the unit safe, flushing with Oxygen-free-Nitrogen must be performed. This procedure may have to be repeated multiple times. Do not use compressed air or oxygen for this operation.

Flushing is obtained interrupting the system vacuum with OFN and filling until the operating pressure is obtained, then releasing into the atmosphere and restoring the vacuum. This process must be repeated until there is no trace of refrigerant in the system.

When using the final OFN charge, the system must be vented to the atmospheric pressure to allow the intervention. This step is essential to perform brazing operations on the pipes.

Make sure that the vacuum pump intake is not near ignition sources and that there is suitable ventilation.

### Charging operations

In addition to conventional charging operations, the following requirements must be complied with:

- When using charging equipment, make sure that the various refrigerants are not contaminated. Flexible tubes or conduits must be as short as possible to reduce to the minimum the quantity of refrigerant contained.
- Tanks must be kept in a vertical position.
- Before loading the system with refrigerant, check that the cooling system is earthed.
- Label the system when fully charged (unless already labelled).
- Make sure not to fill the cooling system excessively.
- Before recharging the system, the pressure must be tested with OFN. A leak test must be performed after the charging operations but before commissioning. Before leaving the site, perform an additional leak test.

### Dismantling

Before performing this procedure, it is essential that the technician has become familiar with the equipment and the relative details.

We recommend employing good practices for a safe recovery of the refrigerants.

Before performing the operation, take a sample of oil and refrigerant should an analysis be necessary before reusing the regenerated refrigerant. Before performing the operation, check the availability of electricity.

- Become familiar with the equipment and how it functions.
- Electrically isolate the system.

Before attempting the procedure, check that:

- The mechanical manipulation equipment is available, if necessary, to handle refrigerant tanks;
- All the personal protection equipment is available and employed correctly;
- The recovery procedure is monitored at all times by skilled personnel;
- The recovery equipment and tanks comply with suitable standards.
- If possible, pump the cooling system.
- If it is not possible to obtain a vacuum, make sure that a collector removes the refrigerant from various parts of the system.
- Before proceeding with the recovery, check that the tank is located on the scales.
- Start up the recovery machine and use it following the instructions by the manufacturer.
- Do not fill the tanks excessively. (Do not exceed 80% of the liquid volume).
- Do not exceed the tank's maximum operating pressure, not even momentarily.
- Once the tanks are filled correctly and the process is over, make sure that the tanks and equipment are immediately removed from the site and that all insulation valves on the equipment are closed.
- The refrigerant recovered must not be loaded into another cooling system unless it has been cleaned and checked.

### Labelling

Equipment must be labelled reporting the dismantling and emptying of the refrigerant.

Labels must be dated and signed.

Make sure all the equipment is labelled and reporting the presence of flammable refrigerant.

### Recovery

When removing the refrigerant from the system, please adopt good practices to remove all refrigerants safely in case of both assistance or decommissioning operations.

When transferring the refrigerant into the tanks, make sure only suitable tanks are used to recover the refrigerant.

Make sure enough tanks are used.

All the tanks to be used are designated for the recovered refrigerant and are labelled for that specific refrigerant (e.g. special tanks for refrigerant collection).

Tanks must be equipped with a perfectly-functioning safety valve and relative interception valves.

Empty recovery tanks are evacuated and, if possible, cooled before recovery.

Recovery equipment must be perfectly functioning with the respective instruction booklets at hand and they must be suitable to recover flammable refrigerants. A series of perfectly-functioning calibrated scales must also be available.

Flexible tubes must be equipped with leak-proof disconnection fittings in good condition. Before using the recovery machine, make sure it is in good condition, maintained and that all associated electrical components are sealed to avoid combustion in case of a refrigerant leak. Please contact the manufacturer in case of doubt.

The refrigerant recovered must be taken to the supplier in suitable recovery tanks and with the relative waste transfer note suitably filled in.

Do not mix the refrigerants in the recovery units nor in the tanks.

If it is necessary to remove compressors or compressor oils, make sure they are evacuated to an acceptable level to make sure no trace is left of the flammable refrigerant inside the lubricant. The evacuation process must be performed before taking the compressors back to the suppliers.

The electric resistance must be used with the compressor body only to accelerate this process.

Operations to discharge the oil from the system must be performed in full safety.

### Transport, mark and storage

- 1 Transport of equipment containing flammable refrigerants  
Compliance with transport regulations
- 2 Marking of equipment with symbols  
Compliance with local regulations
- 3 Disposal of equipment employing flammable refrigerants  
Compliance with national regulations
- 4 Storage of equipment/devices  
The equipment must be stored in compliance with the instructions provided by the manufacturer.
- 5 Storing packed (unsold) equipment  
Packing must be performed in such a way that mechanical damage to the equipment inside it does not cause refrigerant leaks.  
The maximum number of elements that can be stored together is determined by local regulations.

## Safety

Operate in compliance with safety regulations in force.

To carry out the operations use protection devices:

gloves, goggles, helmet, headphones, protective knee pads.

All operations must be carried out by personnel trained on possible risks of a general nature, electrical and deriving from operating with equipment under pressure.

Only qualified personnel can operate on the unit, as required by the regulation in force.

## General

Maintenance must be performed by authorized centres or by qualified personnel

The maintenance allows to:

- maintaining the unit efficient
- reduce the deterioration speed all the equipment is subject to over time
- collect information and data to understand the efficiency state of the unit and prevent possible faults

### WARNING

⇒ *Before checking, please verify the following:*

⇒ *the electrical power supply line should be isolated at the beginning*

⇒ *the line isolator device is open, locked and equipped with the suitable warning sign*

⇒ *make sure no tension is present*

⇒ *After switching the power off, wait at least 5 minutes before accessing to the electrical panel or any other electrical component.*

⇒ *Before accessing check with a multimeter that there are no residual stresses.*

## Frequency of interventions

Perform an inspection every 6 months.

However, frequency depends on the type of use.

Pan inspections at close intervals in the event of:

- frequent use (continuous or very intermittent use, near the operating limits, etc)
- critical use (service necessary)

### WARNING

⇒ *Before any work read: Chapter. SAFETY WARNINGS FOR OPERATIONS ON UNITS CONTAINING R32*



Do not go up to the surface  
Not placing heavy objects

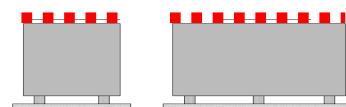



## Recommended periodic checks sheet

	intervention frequency (months)	1	6	12
1	Presence of corrosions			X
2	Panel fixing			X
3	Fan fixing		X	
4	coil cleaning		X	
5	bowl cleaning + sanitisation		X	
6	outflow test		X	
7	air filters cleaning / inspection	X		
8	air flow rate measurement			X
9	channelling: anti-vibration devices and fastenings check			X
10	check of the fixing and the insulation of the power lead			X
11	check of the earthing cable			X
12	Electric panel cleaning			X
13	power remote controls status			X
14	clamp fastening, cable isolation integrity			X
15	Voltage and phase unbalancing (no load and on-load)		X	
16	Absorptions of the single electrical loads		X	
17	compressor crankcase heaters test		X	
18	Checking for leaks *			*
19	cooling circuit work parameter detection		X	
20	safety valve *			*
21	protective device test: pressure switches, thermostats, flow switches etc..			X
22	control system test: setpoint, climatic compensations, capacity stepping, air flow-rate variations			X
23	Control device test: alarm signalling, thermometers, probes, pressure gauges etc			X
24	electrical heaters check - option			X
25	water coil check - option			X
26	Enthalpy wheel module inspection / cleaning (enthalpy wheel and G4 filters)	X		

### NOTE

⇒ *\*Refer to the local regulations. Companies and technicians performing installation, maintenance/repair, leak control and recovery operations must be CERTIFIED as set out by the local regulations.*

## Unit booklet

It's advisable to create a unit booklet to take notes of the unit interventions.

In this way it will be easier to adequately note the various interventions and aid any troubleshooting.

Report on the booklet:

- date
- intervention description
- carried out measures etc.

## Structure

Check the condition of the parts making up the structure

Paint so as to eliminate or reduce oxidation at the points in the unit where this problem may occur

Check that the panelling is fastened correctly

Poor fastening may give rise to malfunctions and abnormal noise and vibration

## Outdoor air coil

Contact with the exchanger fins can cause cuts: wear protective gloves to perform the above described operations.

It is extremely important that the battery gives the maximum thermal exchange; therefore, its surface must be cleaned from dust and deposits.

Remove all impurities from the surface.

Using an air pressure gun, clean the aluminum surface of the battery; be careful to direct the air in the opposite direction of the fan air movement.

Hold the gun parallel to the fins to avoid damages.

As an alternative, vacuum cleaner can be used to suck impurities from the air input side.

Verify that the aluminum fins are not bent or damaged, in the event of damages contact the authorized assistance center and get the fins straightened in order to restore the initial condition for an optimal air flow.

## Indoor air coil

Contact with the exchanger fins can cause cuts: wear protective gloves to perform the above described operations.

The finned surfaces of the cooling coils and, in particular, the condense collection bowls constitute places where microorganisms and moulds greatly flourish.

It is very important to foresee periodical cleaning with suitable detergents and, eventually, disinfect with sanitising products.

## Condensation collection basin

Dirt or scale can give rise to clogging.

Also, microorganisms and mould can flourish in the bowl.

It is very important to foresee periodical cleaning with suitable detergents and, eventually, disinfect with sanitising products.

Once cleaning is completed, pour water inside the bowl to check the regular outflow.

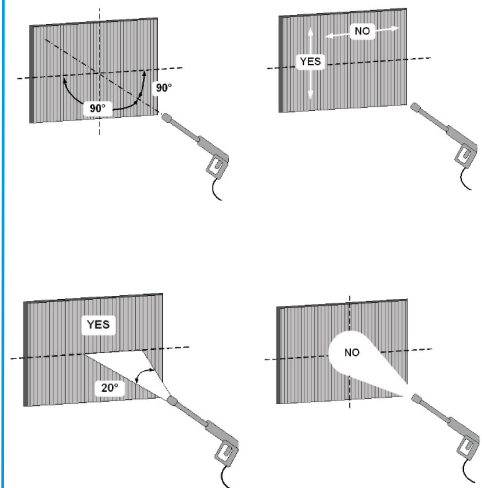

## Removable basin

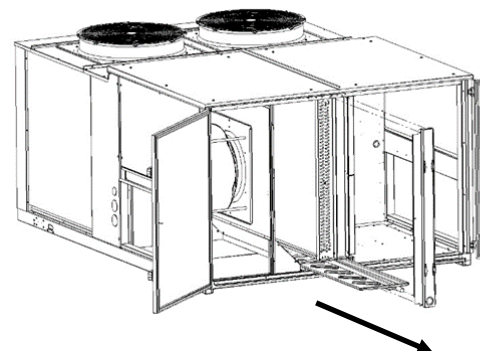

## G4 Folded air filters (ISO 16890 Coarse 60%)

It is very important for the air treatment coil to offer maximum thermal exchange: the unit must always work with clean and installed filters.

Cleaning and replacement of filters are very important from an hygienic-sanitary point of view.

Operation with clogged filters leads to a reduction in the air flow rate with malfunctionings and block, up to possible breaks in the unit.

The frequency with which the filters must be checked depends on the quality of the air, the unit operation hours, the dustiness and crowding of rooms.

Frequency can indicatively vary from WEEKLY to MONTHLY.

It is advised to start with frequent checks, subsequently adjusting frequency to degree of detected dirt.

- 1 Remove the closing panels
- 2 Delicately remove the filter avoiding dirtying the area below
- 3 Check the condition, if necessary proceed with the replacement

Do not wash the filters, washing can compromise their functionality.

Old filters must be disposed of according to the current standards.

## F7 filters (ISO 16890 ePM1 55%)/F9 (ISO 16890 ePM1 80%)

### Option

The filters are not renewable, once dirty they must be replaced.

- 1 Open the access panel
- 2 Delicately remove the filter avoiding dirtying the area below
- 3 Insert the new filters, with the pockets vertically
- 4 Close the panel
- 5 Dispose of the old filters sending them to specialised recycling or collection centres (keep to the standards in force)

## Electric heaters

### Option

Check:

- cleaning state
- fastening
- presence of corrosion

## Electric heaters

Main board: DIP SWITCH



1 step electric heater

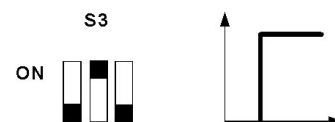

2 step electric heater

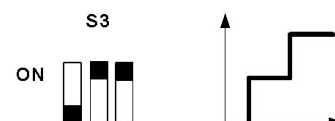

## iFD Electronic filters (ISO 16890 ePM1 90%)

### Option

Impurities can cause a decrease in filtration efficiency and also an increase in the load losses of the component which increase the power consumption of the supply fan. For this reason it is mandatory to clean the filter.

⇒ Do not use water hotter than 50°C to clean the filters.

⇒ Do not use air hotter than 50°C to dry the filters.

Below is the sequence to follow:

- 1 Remove the iFd filter cell from the aluminum frame
- 2 First use a soft brush or vacuum cleaner to clean the floating dust on the surface of the filter; then clean the module with water (you can directly put the module on the faucet for washing)
- 3 Then spray the kitchen cleanser evenly on the IFD filter and ensure that the front and back sides and the holes are sprayed with cleanser (But, strong acid and strong alkaline type cleanser is strictly prohibited)
- 4 Wait for 5~10 mins
- 5 Then, use a soft brush to remove the dust on the surface of the filter (be careful not to damage the module)
- 6 Finally, wash the IFD filter with clean water (if part of the IFD filter is not cleaned, it is recommended to repeat the above 1-5 steps)
- 7 It is recommended to dry the filter cell in an open or dry place. Closed and / or humid places can prevent the filter from completely drying  
The entire cell must dry completely before restoring the electrical connections on the machine.  
Make sure the filter cell electrical connectors are completely dry before making the connections.  
A connector that is still wet / damp can cause irreversible damage to the entire filter cell.

2



3



4



5



### Air filter summary tables

#### CSRN-iY 20.2

FILTER TYPE	DIMENSION	QUANTITY
FOLDED FILTER (G4)	L592 H592 W48	4
FINE FILTER (F7)	L592 H592 W96	4
FINE FILTER (F9)	L592 H592 W98	4
ELECTROSTATIC FILTER iFD	L592 H490 W152	4

## CSRN-iY 28.2

FILTER TYPE	DIMENSION	QUANTITY
FOLDED FILTER (G4)	L592 H592 W48	6
FINE FILTER (F7)	L592 H592 W96	6
FINE FILTER (F9)	L592 H592 W98	6
ELECTROSTATIC FILTER iFD	L592 H490 W152	6

## CSRN-iY 40.2

FILTER TYPE	DIMENSION	QUANTITY
FOLDED FILTER (G4)	L592 H592 W48	3
FOLDED FILTER (G4)	L592 H490 W48	6
FINE FILTER (F7)	L592 H592 W96	3
FINE FILTER (F7)	L592 H490 W96	6
FINE FILTER (F9)	L592 H592 W98	3
FINE FILTER (F9)	L592 H490 W98	6
ELECTROSTATIC FILTER iFD	L592 H592 W152	3
ELECTROSTATIC FILTER iFD	L592 H490 W152	6

## CSRN-iY 56.4

FILTER TYPE	DIMENSION	QUANTITY
FOLDED FILTER (G4)	L592 H592 W48	4
FOLDED FILTER (G4)	L592 H490 W48	8
FINE FILTER (F7)	L592 H592 W96	4
FINE FILTER (F7)	L592 H490 W96	8
FINE FILTER (F9)	L592 H592 W98	4
FINE FILTER (F9)	L592 H490 W98	8
ELECTROSTATIC FILTER iFD	L592 H592 W152	4
ELECTROSTATIC FILTER iFD	L592 H490 W152	8

## CSRN-iY 20.2 and 28.2 / ENTHALPY WHEEL

FILTER TYPE	DIMENSION	QUANTITY
FOLDED FILTER (G4)	L592 H592 W48	4

## CSRN-iY 40.4 and 56.4 / ENTHALPY WHEEL

FILTER TYPE	DIMENSION	QUANTITY
FOLDED FILTER (G4)	L592 H5490 W48	4

### Compressor crankcase heater

Check:

- fastening
- operation

### Immersed electrode humidifier

#### Option

⇒ Connexion humidificateur: 1/2" M

Do not use solvents or detergents to clean the plastic components.

For descaling use a vinegar or acetic acid solution at 20%, subsequently rinsing with water.

### Compressor crankcase heater

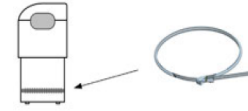

Periodical checks	
15 days	Cylinder: not over 300 hours of work checking operation, general state, no leaks
90 days	Cylinder: not over 1000 hours of work checking operation, general state, no leaks, any replacement
1 year	Cylinder: not over 2500 hours of work (disposable cylinders) Load solenoid valve replacement: disconnect electric power supply, dismantle valve, clean the filter. Drain solenoid valve: disconnect electric power supply, remove reel and dismantle valve body and any impurity and rinse. The power supply bowl, piping: check they are free and without impurities.
5 years	Cylinder: not over 10000 hours of work (inspectional cylinders) replacement

### Humidifier cylinder drainage

Cylinder must be drained in these situations:

- cleaning of the cylinder
- emptying of the cylinder to avoid ice forming
- replacement of the cylinder

The manual drainage is carried out by means of selector SA7: see ELECTRIC CONNECTIONS chapter.

### Replacement of the cylinder

To remove the cylinder:

- completely drain the water
- interrupt power supply voltage of humidifier by means of the unit isolator
- remove the vapour pipe from the cylinder
- disconnect the electric connections of the electrodes and remove the pins from the high level electrodes
- loosen the ring nut to remove the pipe unions and the filter (when filter is outside the cylinder)
- lift the cylinder to remove it

Before mounting it:

- the filter body does not require replacing, wash it with water and remount it on the new cylinder, using the new gasket provided with the latter
- check the seal gasket between the cylinder and the drain unit
- remount the cylinder repeating the operations in reverse order

### UV-C lamps

#### Option

#### Caution

- ⇒ *Direct radiation device: causes eye irritation and skin rashes.*
- ⇒ *Any maintenance operation must be carried out with the lamps off...*
- ⇒ *Do not touch the glass part with hands.*

The UV-C lamps are on when the supply fans are operating.

Clean with cloth and alcohol to remove dust.

Replace the lamp after 9,000 hours of operation.

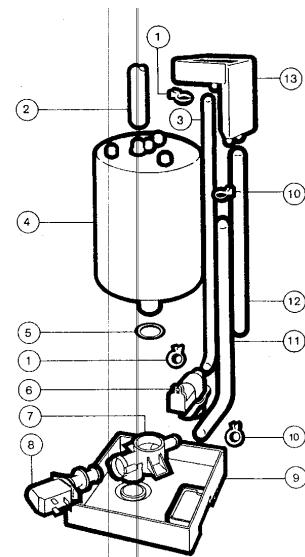

- 1 pipe fixing spring
- 2 vapour pipe
- 3 load pipe
- 4 vapour cylinder
- 5 seal O-rings
- 6 load valve
- 7 valves support
- 8 drain valve
- 9 bottom tank
- 10 pipe fixing spring
- 11 load pipe
- 12 too full pipe
- 13 fill tank



## ENTHALPY WHEEL MAINTENANCE

In order to ensure the best performance, rotary recuperators require simple periodic maintenance as follows:

### a) clean the appliance from fibre, dust or other build-ups;

The appliances can be cleaned with compressed air (in case of dust deposits), taking care not to damage the plates and seals, or by spraying greasy deposits with a cleaning detergent.

### b) check and inspect the motor and rotor;

The rotor must be checked regularly to prevent dust and dirt from settling. Even if the treatment unit has filters installed, these can break allowing dirt to pass through and clog the rotor.

If there are dust and dirt deposits on the rotor, they can be removed easily with one of the following methods:

- Vacuum cleaner, for small dry deposits;
- Compressed air, for significant dry deposits; take care not to damage the rotor;
- High-pressure cleaner with hot water (max. 70°C) or a cleaning detergent spray (e.g. decade, nd-150, chem zyme, primasept, poly-det, oakite 86m or similar) to remove greasy deposits, for heavy, non-drying deposits. Do not use strong alkaline substances or solutions or other substances that can corrode the rotor.

The minimum distance of the nozzle from the rotor should be no less than 30 cm, the maximum pressure is 50 bar (Karcher cleaning device).

After cleaning, blow any water dripped inside out of the rotor.

### c) check the condition and tension of the drive belts

For correct operation:

- Check tension of the drive belt after the first 100 hours of operation.
- Regularly check the condition of the drive belt for wear and tension when the wheel is stationary.
- Tension can be increased by shortening the belt
- Ensure that the belt is long enough to transmit rotation correctly, without slipping. .

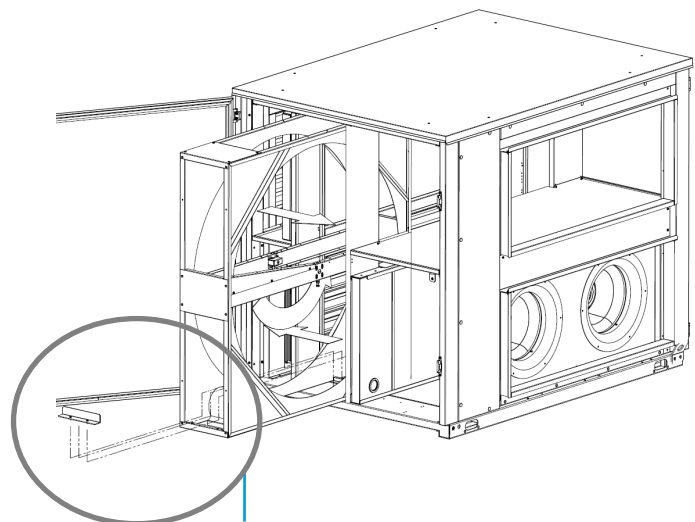



## Disconnection

### WARNING

⇒ Before performing any operation, read the warnings found in the Maintenance chapter: SAFETY WARNINGS FOR OPERATIONS ON UNITS CONTAINING R32

Avoid leak or spills into the environment.

Before disconnecting the unit, the following must be recovered, if present:

- refrigerant gas
- Anti-freeze solutions in the hydraulic circuit

Awaiting decommissioning and disposal, the unit can also be stored outdoors, as bad weather and rapid changes in temperature do not harm the environment provided that the electric, cooling and hydraulic circuits of the unit are intact and closed.

### WEEE INFORMATION

The manufacturer is registered on the EEE National Register, in compliance with implementation of Directive 2012/19/EU and relevant national regulations on waste electrical and electronic equipment.

This Directive requires electrical and electronic equipment to be disposed of properly.

Equipment bearing the crossed-out wheellie bin mark must be disposed of separately at the end of its life cycle to prevent damage to human health and to the environment.

Electrical and electronic equipment must be disposed of together with all of its parts.

To dispose of “household” electrical and electronic equipment, the manufacturer recommends you contact an authorised dealer or an authorised ecological area.

“Professional” electrical and electronic equipment must be disposed of by authorised personnel through established waste disposal authorities around the country.

In this regard, here is the definition of household WEEE and professional WEEE:

WEEE from private households: WEEE originating from private households and WEEE which comes from commercial, industrial, institutional and other sources which, because of its nature and quantity, is similar to that from private households. Subject to the nature and quantity, where the waste from EEE was likely to have been by both a private household and users of other than private households, it will be classed as private household WEEE;

Professional WEEE: all WEEE which comes from users other than private households.

This equipment may contain:

refrigerant gas, the entire contents of which must be recovered in suitable containers by specialised personnel with the necessary qualifications;

- lubrication oil contained in compressors and in the cooling circuit to be collected;
- mixtures with antifreeze in the water circuit, the contents of which are to be collected;
- mechanical and electrical parts to be separated and disposed of as authorised.

When machine components to be replaced for maintenance purposes are removed or when the entire unit reaches the end of its life and needs to be removed from the installation, waste should be separated by its nature and disposed of by authorised personnel at existing collection centres.



### General

In this section the most common situations are indicated, as these cannot be controlled by the manufacturer and could be a source of risk situations for people or things.

### Danger zone

This is an area in which only an authorised operator may work.

The danger zone is the area inside the unit which is accessible only with the deliberate removal of protections or parts thereof.

### Handling

The handling operations, if implemented without all of the protection necessary and without due caution, may cause the drop or the tipping of the unit with the consequent damage, even serious, to persons, things or the unit itself.

Handle the unit following the instructions provided in the present manual re-garding the packaging and in compliance with the local regulations in force.

Should the refrigerant leak please refer to the refrigerant "Safety sheet".

### Installation

The incorrect installation of the unit could cause water leaks, condensate accumulation, leaking of the refrigerant, electric shock, poor operation or damage to the unit itself.

Check that the installation has been implemented by qualified technical personnel only and that the instructions contained in the present manual and the local regulations in force have been adhered to.

The installation of the unit in a place where even infrequent leaks of inflammable gas and the accumulation of this gas in the area surrounding the area occur could cause explosions or fires.

Carefully check the positioning of the unit.

The installation of the unit in a place unsuited to support its weight and/or guarantee adequate anchorage may result in consequent damage to things, people or the unit itself.

Carefully check the positioning and the anchoring of the unit.

Easy access to the unit by children, unauthorised persons or animals may be the source of accidents, some serious.

Install the unit in areas which are only accessible to authorised person and/or provide protection against intrusion into the danger zone.

### General risks

Smell of burning, smoke or other signals of serious anomalies may indicate a situation which could cause damage to people, things or the unit itself.

Electrically isolate the unit (yellow-red isolator).

Contact the authorised service centre to identify and resolve the problem at the source of the anomaly.

Accidental contact with exchange batteries, compressors or other components may cause injuries and/or burns.

Always wear suitable clothing including protective gloves to work inside the danger zone.

Maintenance and repair operations carried out by non-qualified personnel may cause damage to persons, things or the unit itself.

Always contact the qualified assistance centre.

Failing to close the unit panels or failure to check the correct tightening of all of the panelling fixing screws may cause damage to persons, things or the unit itself.

Periodically check that all of the panels are correctly closed and fixed.

If there is a fire the temperature of the refrigerant could reach values that increase the pressure to beyond the safety valve with the consequent possible projection of the refrigerant itself or explosion of the circuit parts that remain isolated by the closure of the tap.

Do not remain in the vicinity of the safety valve and never leave the refrigerating system taps closed.

### Electric parts

An incomplete attachment line to the electric network or with incorrectly sized cables and/or unsuitable protective devices can cause electric shocks, intoxication, damage to the unit or fires.

Carry out all of the work on the electric system referring to the electric layout and the present manual ensuring the use of a system thereto dedicated.

An incorrect fixing of the electric components cover may lead to the entry of dust, water etc inside and may consequently electric shocks, damage to the unit or fires.

Always fix the unit cover properly.

When the metallic mass of the unit is under voltage and is not correctly connected to the earthing system it may be as source of electric shock and electrocution.

Always pay particular attention to the implementation of the earthing system connections.

Contact with parts under voltage accessible inside the unit after the removal of the guards can cause electric shocks, burns and electrocution.

Open and padlock the general isolator prior to removing the guards and signal work in progress with the appropriate sign.

Contact with parts that could be under voltage due to the start up of the unit may cause electric shocks, burns and electrocution.

When voltage is necessary for the circuit open the isolator on the attachment line of the unit itself, padlock it and display the appropriate warning sign.

### Moving parts

Contact with the transmissions or with the fan aspiration can cause injuries.

Prior to entering the inside of the unit open the isolator situated on the connection line of the unit itself, padlock and display the appropriate warning sign.

Contact with the fans can cause injury.

Prior to removing the protective grill or the fans, open the isolator on the attachment line of the unit itself, padlock it and display the appropriate warning sign.

### Refrigerant

The intervention of the safety valve and the consequent expulsion of the gas refrigerant may cause injuries and intoxication.

Always wear suitable clothing including protective gloves and eyeglasses for operations inside the danger zone.

Should the refrigerant leak please refer to the refrigerant "Safety sheet".

Contact between open flames or heat sources with the refrigerant or the heating of the gas circuit under pressure (e.g. during welding operations) may cause explosions or fires.

Do not place any heat source inside the danger zone.

The maintenance or repair interventions which include welding must be carried out with the system off.

### Hydraulic parts

Defects in tubing, the attachments or the removal parts may cause a leak or water projection with the consequent damages to people, things or shortcircuit the unit.

# General technical data

## Performances - Standard airflow

SIZE				20.2		28.2		40.4		56.4	
OPERATION				NOM*	MAX**	NOM*	MAX**	NOM*	MAX**	NOM*	MAX**
<b>COOLING</b>											
Cooling capacity	1	kW	59,7	68,5	79,4	93,7	117	129	157	171	
Sensible capacity	1	kW	50,6	54,8	66,9	73,5	90,4	96,1	124	130	
Compressor power input	1	kW	18,5	26,5	22,2	34,4	38,7	50,3	50,7	64,9	
EER	1	-	3,23	2,59	3,58	2,72	3,02	2,56	3,11	2,64	
Cooling capacity (EN14511:2018)	5	kW	59,0		78,0		116,2		155,2		
EER (EN14511:2018)	5	-	2,86		2,88		2,67		2,73		
SEER	6		4,92		4,72		4,85		4,56		
$\eta_{sc}$	6	%	193,8		185,8		191,0		179,4		
Eurovent seasonal efficiency class			A		A		A		B		
Cooling capacity	2	kW	62,2	71,4	82,7	97,5	122	134	164	178	
Sensible capacity	2	kW	53,0	57,2	70,0	76,5	94,4	100	129	135	
Compressor power input	2	kW	18,7	27,0	22,3	34,8	39,2	51,1	51,2	65,5	
EER	2	-	3,33	2,65	3,70	2,80	3,11	2,63	3,2	2,72	
Cooling capacity	3	kW	65,9	75,7	87,6	103,0	129	142	174	189	
Sensible capacity	3	kW	55,9	60,2	73,7	80,7	99,5	105	159	171	
Compressor power input	3	kW	18,1	26,1	21,6	33,7	38	49,6	49,6	63,6	
EER	3	-	3,63	2,89	4,05	3,06	3,4	2,87	3,5	2,97	
<b>HEATING</b>											
Heating capacity	1	kW	57,5	78,5	76,1	101,0	119	155	160	201	
Compressor power input	1	kW	13,7	24,0	17,2	29,5	32,6	54,7	41,9	67,2	
COP	1	-	4,20	3,27	4,43	3,43	3,65	2,83	3,81	2,99	
Heating capacity (EN14511:2018)	7	kW	58,0		76,8		119,7		162,3		
COP (EN14511:2018)	7	-	3,73		3,72		3,19		3,38		
SCOP	6		3,91		3,79		3,81		3,92		
$\eta_{sh}$	6	%	153,4		148,6		149,4		153,8		
Eurovent seasonal efficiency class			A+		A		A+		A+		
Heating capacity	2	kW	58,2	79,3	76,4	101,0	120	156	160	199	
Compressor power input	2	kW	12,7	22,2	15,8	26,9	30,2	51	38,3	61,3	
COP	2	-	4,58	3,56	4,85	3,74	3,97	3,07	4,17	3,25	
Heating capacity	3	kW	61,0	83,1	80,1	105,0	126	164	167	209	
Compressor power input	3	kW	12,6	22,1	15,7	26,7	30,1	50,7	38	61	
COP	3	-	4,84	3,76	5,11	3,94	4,18	3,23	4,4	3,43	
Recovery efficiency REVO	4	%	82	86	81	83	80	86	82	87	

II The Product is compliant with the Erp (Energy Related Products) European Directive. It includes the Commission delegated Regulation (EU) No 2016/2281, also known as Ecodesign Lot21.

Contains fluorinated greenhouse gases (GWP 675)

Performances in cooling: Indoor air temp. 27°C D.B./19°C W.B., Entering external exchanger air temperature 35°C D.B./24°C W.B., EER referred only to compressors

Performance in Heating: Indoor air temp. 20°C D.B./12°C W.B., entering air to the external exchanger 7°C D.B./6°C W.B. COP referred only to compressors

1. Full recirculation performance
2. Performance with 30% outdoor air
3. Performance with 30% outdoor air, including energy recovery on exhaust air
4. Energy recovery efficiency determined on exhaust air. Indoor temperature 20°C DB/12°C WB, outdoor temperature 7°C DB/6°C WB
5. Full recirculation capacity according to EN 14511-2018, indoor air temperature 27°C DB/19°C WB; outdoor temperature 35°C. EER in accordance with EN 14511-2018
6. Data calculated in compliance with EN 14825:2018.
7. Full recirculation capacity according to EN 14511-2018, indoor air temperature 20°C; outdoor temperature 7°C DB/6°C WB COP in accordance with EN 14511-2018

\* NOM = data referring to units in operation with inverter frequency optimised for this application.

\*\* MAX = data referring to units in operation with maximum allowed inverter frequency

## Construction - Standard airflow

SIZE			20.2	28.2	40.4	56.4	
<b>COMPRESSOR</b>							
Type of compressors	1		ROT	SCROLL	ROT	SCROLL	
No. of compressors		No.	2	2	4	4	
Refrigeration circuits		No.	2	2	2	2	
Control capacity		%	20-100%	20-100%	20-100%	20-100%	
Refrigerant charge (C1)	CAK/CBK/CBK-G	2	kg	8,0	9,0	19	21
Refrigerant charge (C2)		2	kg	8,0	9,0	19	21
Refrigerant charge (C1)	CCK-REVO	2	kg	9,5	11	20	22
Refrigerant charge (C2)		2	kg	9,5	11	20	22
<b>AIR HANDLING SECTION FANS (SUPPLY)</b>							
Type of supply fan/motor	3		RAD/EC	RAD/EC	RAD/EC	RAD/EC	
Fan diameter		mm	630	560	630	560	
No. of supply fans		No.	1	2	2	3	
Supply airflow		m <sup>3</sup> /h	13000	17000	23000	32000	
Installed unit power		kW	2,38	2,90	2,38	2,90	
Max. static pressure supply fan	4	Pa	330	450	410	300	
Installed unit power	(VENH opt)		kW	3,82	3,50	3,82	3,50
Max. static pressure supply fan		4	Pa	630	810	690	645
<b>FANS (EXHAUST) ONLY CONFIGURATION CBK-G + EWX</b>							
Type of fans/motor			RAD/EC	RAD/EC	RAD/EC	RAD/EC	
No. of fans			2	2	2	2	
Installed unit power			2,6	2,6	2,6	2,6	
<b>FANS (EXHAUST) ONLY CONFIGURATION CCK-REVO</b>							
Type of fans/motor	3		RAD/EC	RAD/EC	RAD/EC	RAD/EC	
No. of fans		No.	1	2	2	2	
Installed unit power		kW	3,65	1,32	3,65	2,38	
<b>EXTERNAL SECTION FANS</b>							
Type of fans/motor	5		AXIAL/EC	AXIAL/EC	AXIAL/EC	AXIAL/EC	
Fan diameter		mm	750	890	890	750	
No. of fans		No.	2	2	2	4	
Airflow		m <sup>3</sup> /h	26000	42000	50000	60000	
Installed unit power		kW	0,92	1,5	1,5	0,92	
<b>CONNECTIONS</b>							
Condensate drain		mm	32	32	32	32	
<b>POWER SUPPLY</b>							
Standard power supply		V	400/3~/50	400/3~/50	400/3~/50	400/3~/50	

1. ROT = Rotary compressor SCROLL= scroll compressor
2. Indicative values for standard units with possible +/-10% variation. The actual data are indicated on the label of the unit
3. RAD = Radial fan - EC = Electronically Commutated
4. Net pressure available to overcome flow and return pressure losses
5. AXIAL = Axial fan - EC = Electronically Commutated

## Sound level - Nominal operation

SIZE	Sound power level (dB)								Sound power level	Sound pressure level
	Octave band (Hz)									
	63	125	250	500	1000	2000	4000	8000	dB(A)	dB(A)
<b>20.2</b>	61	75	72	76	80	86	72	64	88	70
<b>28.2</b>	75	79	82	82	85	85	76	68	89	70
<b>40.4</b>	82	81	78	79	83	83	76	71	88	69
<b>56.4</b>	72	74	78	80	86	84	78	65	90	70

## Sound levels - Maximum conditions

SIZE	Sound power level (dB)								Sound power level	Sound pressure level
	Octave band (Hz)									
	63	125	250	500	1000	2000	4000	8000	dB(A)	dB(A)
<b>20.2</b>	72	81	76	80	85	85	77	68	90	72
<b>28.2</b>	74	83	78	82	87	87	79	70	91	72
<b>40.4</b>	72	77	80	81	85	85	78	73	90	71
<b>56.4</b>	74	74	77	83	87	87	80	68	92	72

## Sound level - Silent mode

SIZE	Sound power level (dB)								Sound power level	Sound pressure level
	Octave band (Hz)									
	63	125	250	500	1000	2000	4000	8000	dB(A)	dB(A)
<b>20.2</b>	62	75	79	80	84	82	75	66	86	68
<b>28.2</b>	62	75	79	80	84	82	75	66	88	69
<b>40.4</b>	69	76	75	78	82	80	74	70	86	68
<b>56.4</b>	75	73	73	81	84	82	78	65	88	68

## Sound level - Supersilent mode

SIZE	Sound power level (dB)								Sound power level	Sound pressure level
	Octave band (Hz)									
	63	125	250	500	1000	2000	4000	8000	dB(A)	dB(A)
<b>20.2</b>	46	68	68	74	76	84	68	61	85	67
<b>28.2</b>	59	73	78	79	81	80	73	64	86	67
<b>40.4</b>	67	75	73	77	79	79	72	67	84	65
<b>56.4</b>	65	70	70	81	79	77	80	63	86	66

## Sound levels referred to ESP as per EN 14511:2018

SIZE		<b>20.2</b>	<b>28.2</b>	<b>40.4</b>	<b>56.4</b>
Sound power with casing	dB(A)	88	89	88	90
Available static pressure	Pa	200	200	300	350

Data referred to nominal air flow rate.

Measurements are carried out accordingly to UNI EN ISO 9614-1, as required by Eurovent Certification EUROVENT 8/1. It requires a 2 dB(A) tolerance on sound power level, only acoustic value to be certified.

## Operating range (Cooling)

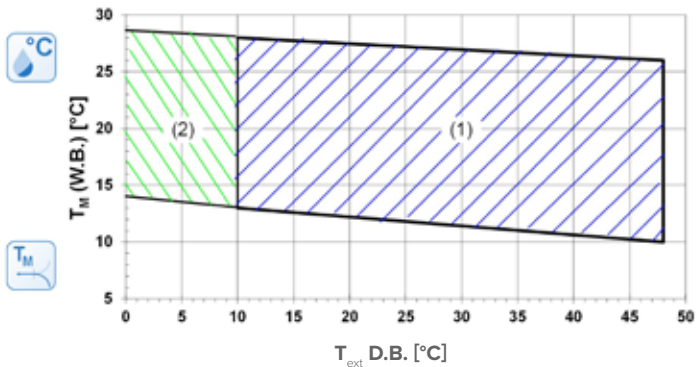

The limits are meant as an indication and they have been calculated by considering:

- general and non specific sizes,
- standard airflow,
- non-critical positioning of the unit and correct operating and maintenance of the unit,
- operating at full load

To verify the operation field of the operating units with percentages of outdoor air, always calculate the  $T_m$  mixing temperature at the internal heat exchanger input.

$T_m$  = Inlet air temperature in the internal exchanger wet bulb temperature (W.B.=WET BULB)

$T_{ext}$  = External exchanger inlet air temperature measured temperature with wet bulb (W.B.=WET BULB)

Within its operating range, the unit can work at a partialized load to maximise energy efficiency

1. Standard unit operating range
2. Operating range of the unit in FREE-COOLING mode (CBK-G and CCK-REVO versions)

### WET BULB TEMPERATURE - EXAMPLE

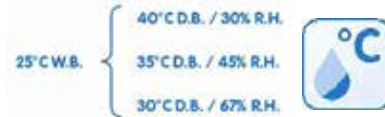

## Operating range (Heating)

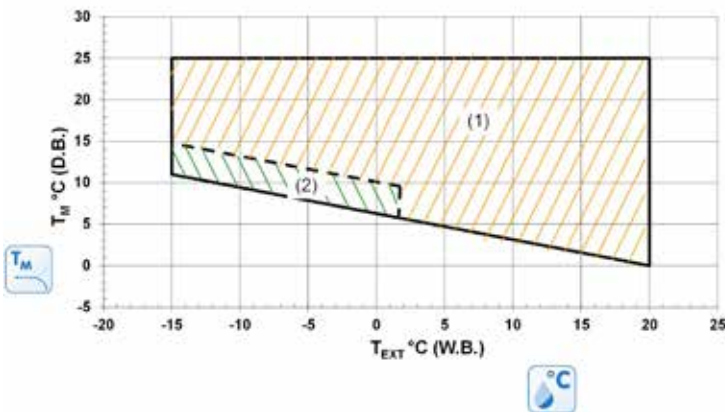

The limits are meant as an indication and they have been calculated by considering:

- general and non specific sizes,
- standard airflow,
- non-critical positioning of the unit and correct operating and maintenance of the unit,
- operating at full load

To verify the operation field of the operating units with percentages of outdoor air, always calculate the  $T_m$  mixing temperature at the internal heat exchanger input.

$T_m$  = Inlet air temperature in the internal exchanger measured temperature with wet bulb (W.B.=WET BULB)

$T_{ext}$  = External exchanger inlet air temperature wet bulb temperature (W.B.= WET BULB)

Within its operating range, the unit can work at a partialized load to maximise energy efficiency

1. Standard operating range
2. Range in which the unit operation is allowed only for a limited period (max 1 hour)

In prolonged heat pump mode with an ambient temperature below 6°C, the unit carries out defrosting cycles with cycle inversion to eliminate the ice that forms on the surfaces of the external exchanger. Moreover, in the event of negative temperatures, it is important to promote the evacuation of water produced by defrosting to avoid the accumulation of ice near the base of the unit. Ensure this does not pose a hazard to property or persons.

With outdoor air temperatures between -10°C and -25°C, the following options will be required:

- Hot water coil / Gas heating module
- Application for low outdoor temperature

# Dimensional drawings

Size 20.2 - Version CAK / CBK / CBK-G / CCK-REVO

DAA800001\_00  
DATA/DATE 13/08/2021

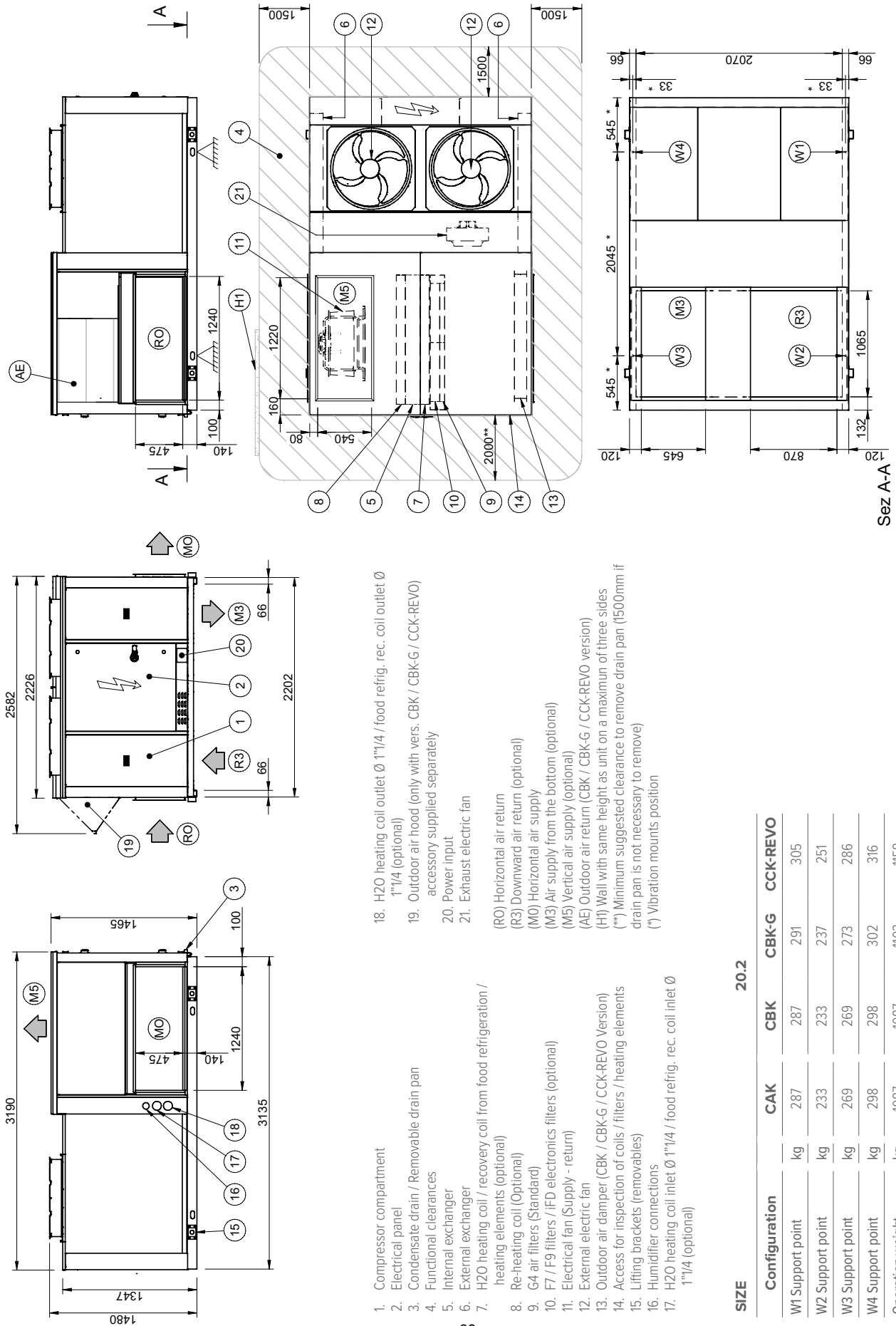

## 20.2

Configuration	CAK	CBK	CBK-G	CCK-REVO
W1 Support point	kg 287	287	291	305
W2 Support point	kg 233	233	237	251
W3 Support point	kg 269	269	273	286
W4 Support point	kg 298	298	302	316
Operation weight	kg 1087	1087	1103	1158
Shipping weight	kg 1114	1114	1130	1185

Optional accessories may result in a substantial variation of the weight show in table



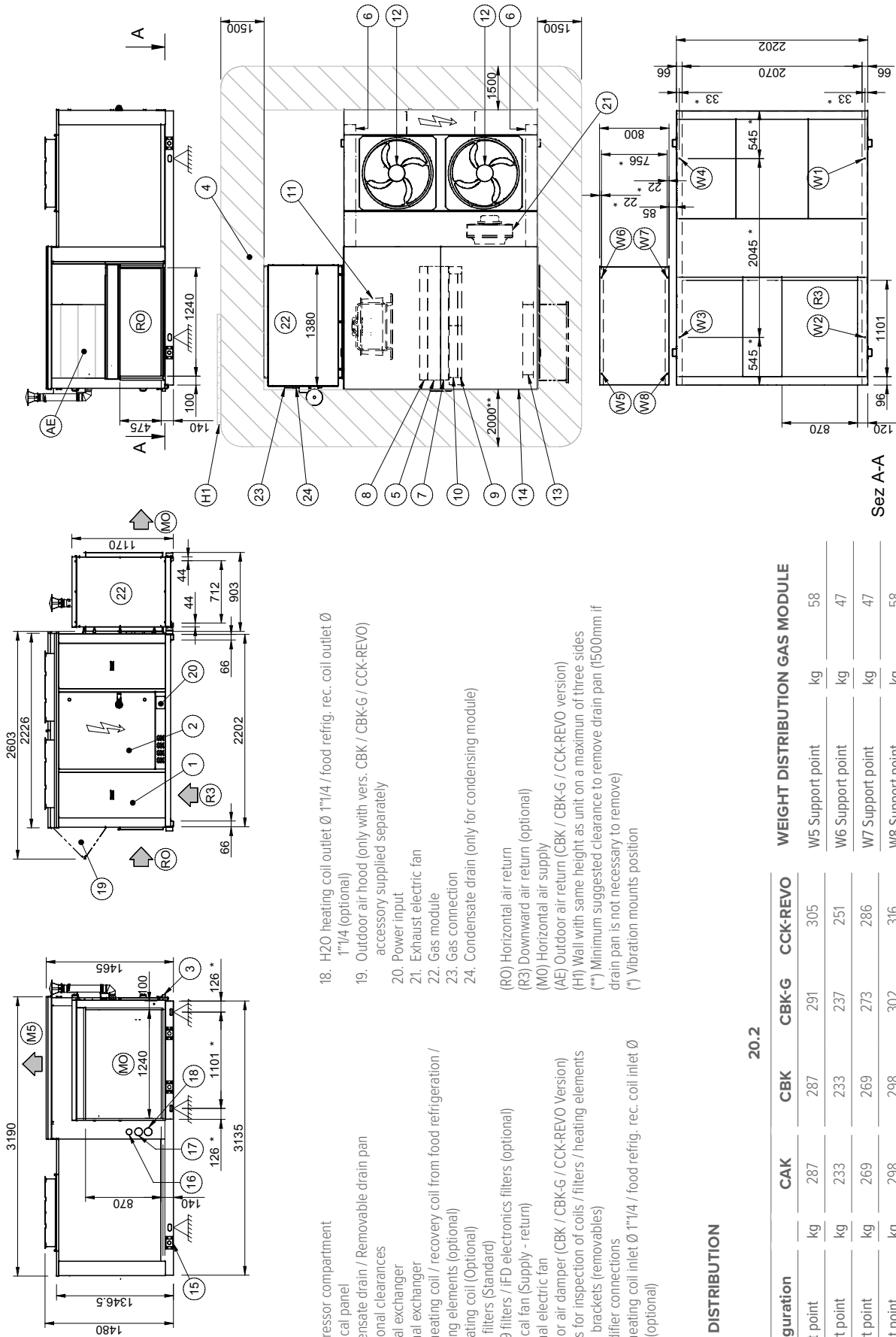

- 18. H2O heating coil outlet Ø 1"1/4 / food refrig. rec. coil outlet Ø 1"1/4 (optional)
  - 19. Outdoor air hood (only with vers. CBK / CBK-G / CCK-REVO) accessory supplied separately
  - 20. Power input
  - 21. Exhaust electric fan
  - 22. Gas module
  - 23. Gas connection
  - 24. Condensate drain (only for condensing module)
- (RO) Horizontal air return  
(R3) Downward air return (optional)  
(WO) Horizontal air supply  
(AE) Outdoor air return (CBK / CBK-G / CCK-REVO version)  
(H1) Wall with same height as unit on a maximum of three sides  
(\*\*) Minimum suggested clearance to remove drain pan (1500mm if drain pan is not necessary to remove)  
(\*) Vibration mounts position

- 1. Compressor compartment
- 2. Electrical panel
- 3. Condensate drain / Removable drain pan
- 4. Functional clearances
- 5. Internal exchanger
- 6. External exchanger
- 7. H2O heating coil / recovery coil from food refrigeration / heating elements (optional)
- 8. Re-heating coil (Optional)
- 9. G4 air filters (Standard)
- 10. F7 / F9 filters / IFD electronics filters (optional)
- 11. Electrical fan (Supply - return)
- 12. External electric fan
- 13. Outdoor air damper (CBK / CBK-G / CCK-REVO Version)
- 14. Access for inspection of coils / filters / heating elements
- 15. Lifting brackets (removables)
- 16. Humidifier connections
- 17. H2O heating coil inlet Ø 1"1/4 / food refrig. rec. coil inlet Ø 1"1/4 (optional)

**WEIGHT DISTRIBUTION**

**20.2**

Configuration	CAK	CBK	CBK-G	CCK-REVO	WEIGHT DISTRIBUTION GAS MODULE
W1 Support point	287	287	291	305	W5 Support point kg 58
W2 Support point	233	233	237	251	W6 Support point kg 47
W3 Support point	269	269	273	286	W7 Support point kg 47
W4 Support point	298	298	302	316	W8 Support point kg 58
Operation weight	1087	1087	1103	1158	Operation weight kg 210
Shipping weight	1114	1114	1130	1185	Shipping weight kg 210

Optional accessories may result in a substantial variation of the weight show in table

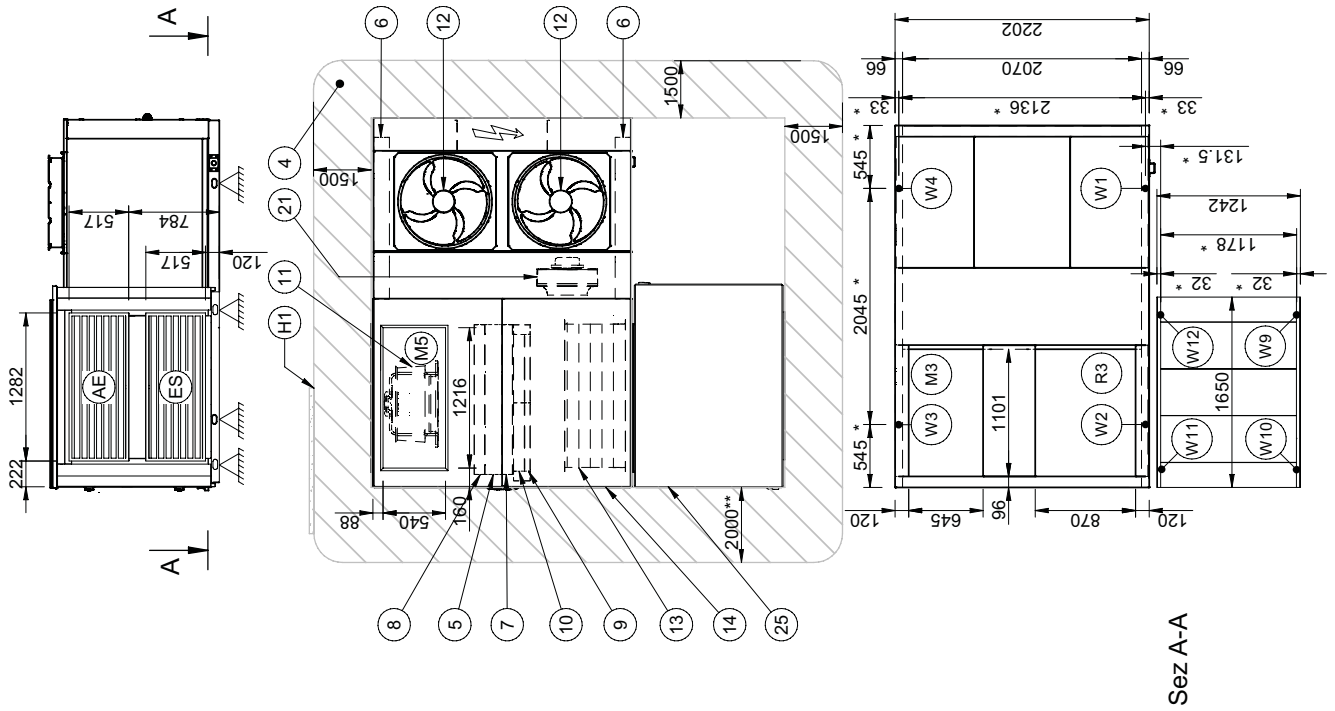

Sez A-A

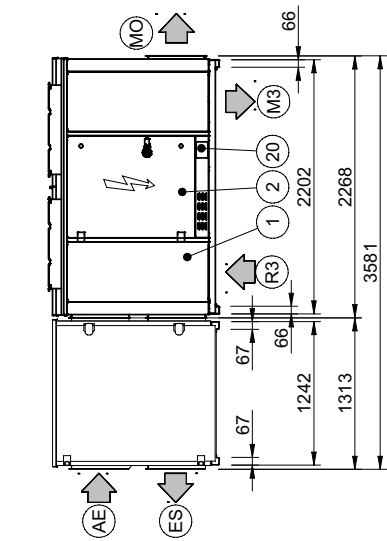

- 19. Outdoor air return cap (Not available with enthalpic wheel)
  - 20. Power input
  - 21. Exhaust electric fan
  - 22. Gas module (Drawing dedicated)
  - 23. Gas connection (Drawing dedicated)
  - 24. Condensate drain (Drawing dedicated)
  - 25. Enthalpy wheel
- (RO) Horizontal air return (Not available with enthalpic wheel)  
 (R3) Downward air return (optional)  
 (M0) Horizontal air supply  
 (M3) Air supply from the bottom (optional)  
 (M5) Vertical air supply (optional)  
 (AE) Outdoor air return (CBK / CBK-G / CCK-REVO version)  
 (ES) Exhausted air expulsion  
 (H1) Wall with same height as unit on a maximum of three sides  
 (\*) Vibration mounts position  
 (\*\*) Minimum suggested clearance to remove drain pan (500mm if drain pan is not necessary to remove)

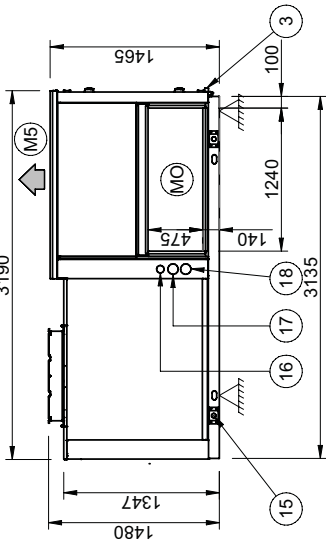

- 1. Compressor compartment
- 2. Electrical panel
- 3. Condensate drain / Removable drain pan
- 4. Functional clearances
- 5. Internal exchanger
- 6. External exchanger
- 7. H<sub>2</sub>O heating coil / recovery coil from food refrigeration / heating elements (optional)
- 8. Re-heating coil (Optional)
- 9. G4 air filters (Standard)
- 10. F7 / F9 filters / IFD electronics filters (optional)
- 11. Electrical fan (Supply - return)
- 12. External electric fan
- 13. Outdoor air damper (CBK / CBK-G / CCK-REVO Version)
- 14. Access for inspection of coils / filters / heating elements
- 15. Lifting brackets (removable)
- 16. Humidifier connections
- 17. H<sub>2</sub>O heating coil input Ø 1"1/4 / recovery coil from food refrigeration, input Ø 1"1/4 (optional)
- 18. H<sub>2</sub>O heating coil output Ø 1"1/4 / recovery coil from food refrigeration, output Ø 1"1/4 (optional)

**WEIGHT DISTRIBUTION**

**SIZE**

Configuration	CBK-G	WEIGHT DISTRIBUTION - ROTARY RECOVERY MODULE
W1 Support point	kg 291	W9 Support point kg 135
W2 Support point	kg 237	W10 Support point kg 135
W3 Support point	kg 273	W11 Support point kg 120
W4 Support point	kg 302	W12 Support point kg 120
Operation weight	kg 1103	Operation weight kg 510
Shipping weight	kg 1130	Shipping weight kg 510

Optional accessories may result in a substantial variation of the weight show in table

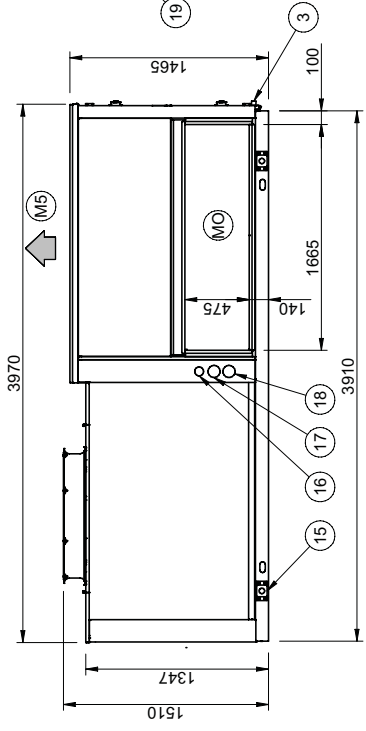
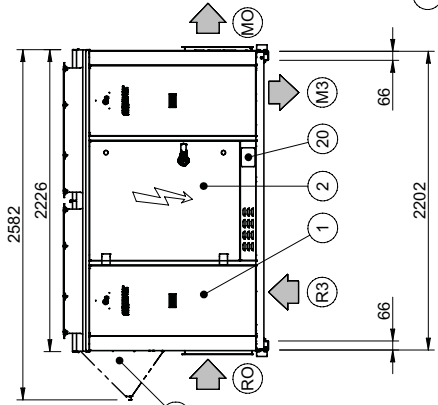
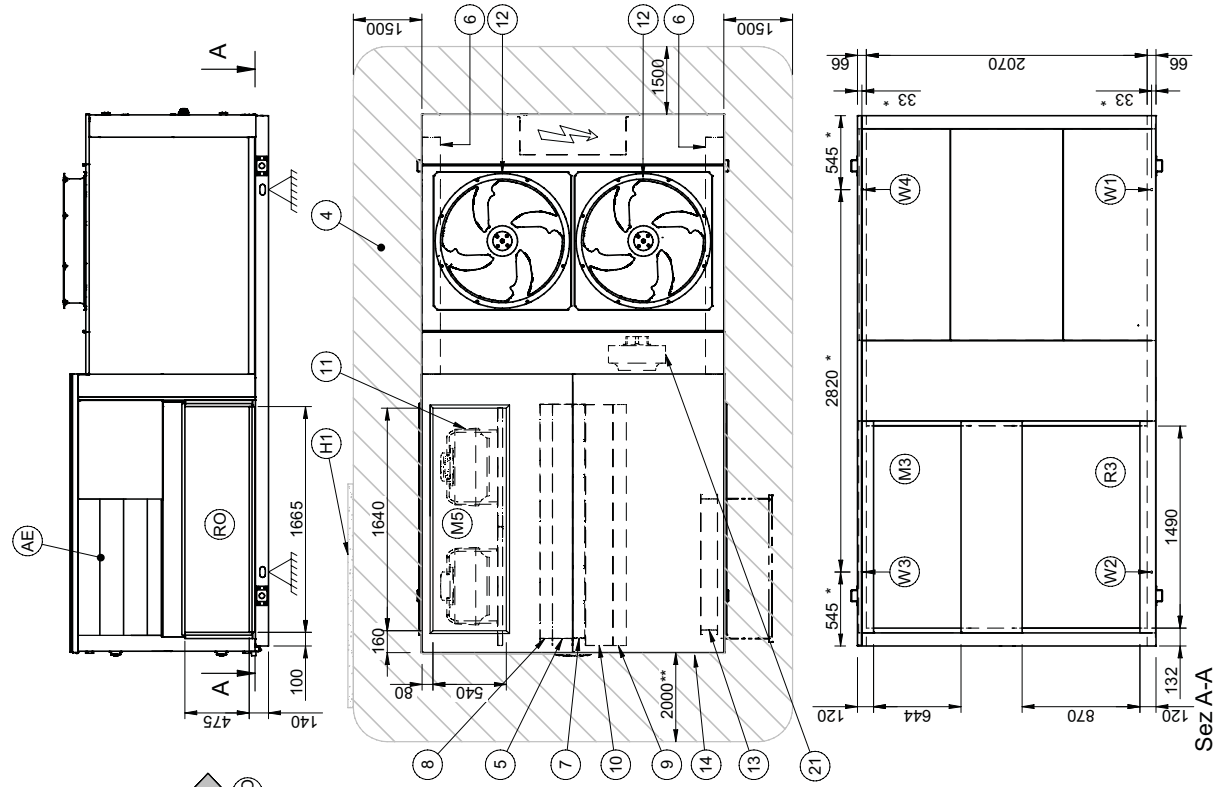

1. Compressor compartment
  2. Electrical panel
  3. Condensate drain / Removable drain pan
  4. Functional clearances
  5. Internal exchanger
  6. External exchanger
  7. H<sub>2</sub>O heating coil / recovery coil from food refrigeration / heating elements (optional)
  8. Re-heating coil (Optional)
  9. G4 air filters (Standard)
  10. F7 / F9 filters / IFD electronics filters (optional)
  11. Electrical fan (Supply - return)
  12. External electric fan
  13. Outdoor air damper (CBK / CBK-G / CCK-REVO Version)
  14. Access for inspection of coils / filters / heating elements
  15. Lifting brackets (removable)
  16. Humidifier connections
  17. H<sub>2</sub>O heating coil input Ø 1"1/4 / recovery coil from food refrigeration, input Ø 1"1/4 (optional)
  18. H<sub>2</sub>O heating coil output Ø 1"1/4 / recovery coil from food refrigeration, output Ø 1"1/4 (optional)
  19. Outdoor air hood (only with vers. CBK / CBK-G / CCK-REVO) accessory supplied separately
  20. Power input
  21. Exhaust electric fan
- (RO) Horizontal air return  
(R3) Downward air return (optional)  
(M0) Horizontal air supply  
(M3) Air supply from the bottom (optional)  
(M5) Vertical air supply (optional)  
(AE) Outdoor air return (CBK / CBK-G / CCK-REVO version)  
(H1) Wall with same height as unit on a maximum of three sides  
(\*\*) Minimum suggested clearance to remove drain pan (1500mm if drain pan is not necessary to remove)  
(\*) Vibration mounts position

**SIZE 28.2**

Configuration	CAK	CBK	CBK-G	CCK-REVO
W1 Support point	kg 312	312	316	330
W2 Support point	kg 258	258	262	276
W3 Support point	kg 294	294	298	311
W4 Support point	kg 323	323	327	341
Operation weight	kg 1187	1187	1203	1258
Shipping weight	kg 1214	1214	1230	1285

Optional accessories may result in a substantial variation of the weight show in table

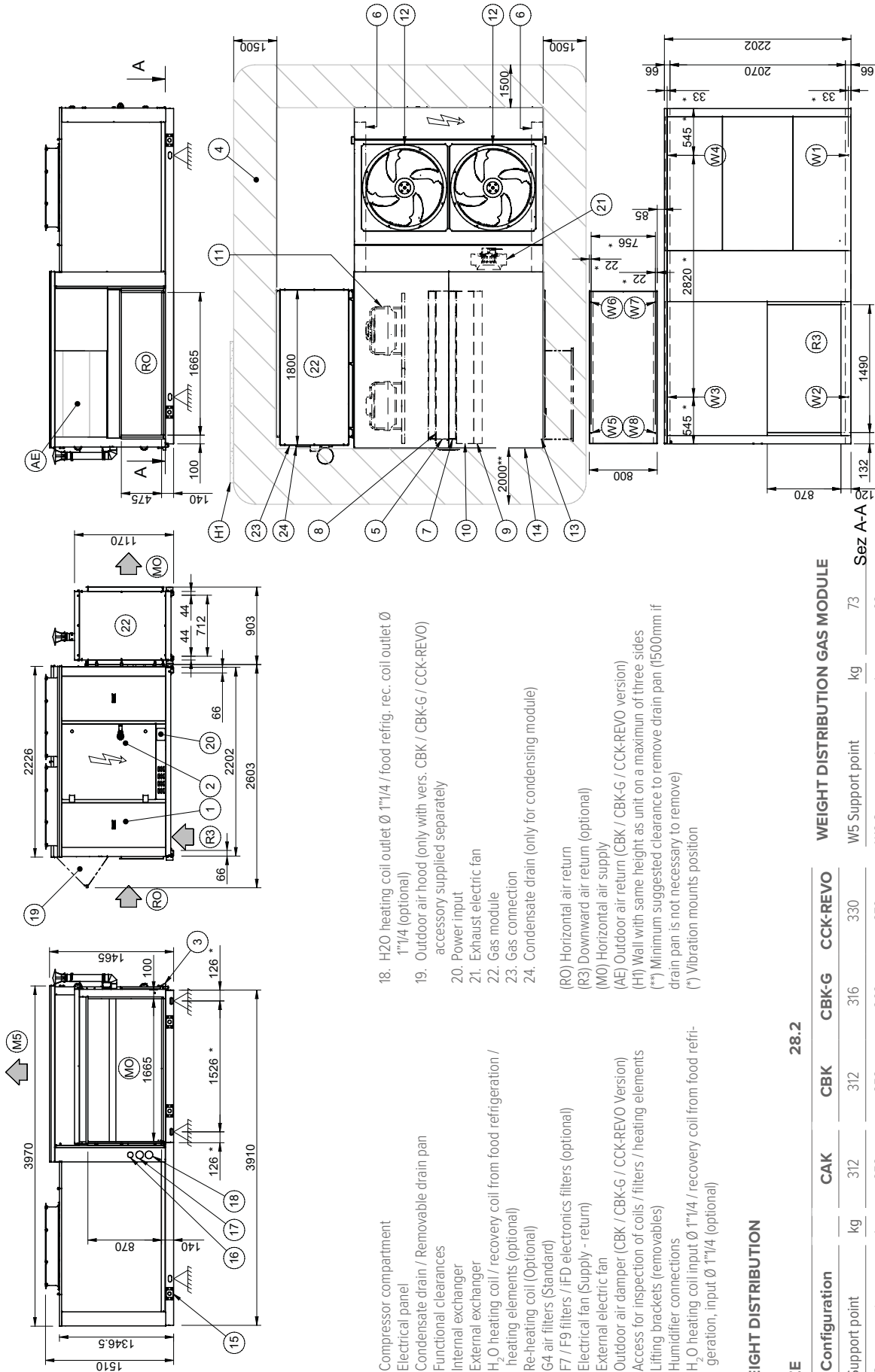

- 1. Compressor compartment
  - 2. Electrical panel
  - 3. Condensate drain / Removable drain pan
  - 4. Functional clearances
  - 5. Internal exchanger
  - 6. External exchanger
  - 7. H<sub>2</sub>O heating coil / recovery coil from food refrigeration / heating elements (optional)
  - 8. Re-heating coil (Optional)
  - 9. G4 air filters (Standard)
  - 10. F7 / F9 filters / I/FD electronics filters (optional)
  - 11. Electrical fan (Supply - return)
  - 12. External electric fan
  - 13. Outdoor air damper (CBK / CBK-G / CCK-REVO Version)
  - 14. Access for inspection of coils / filters / heating elements
  - 15. Lifting brackets (removable)
  - 16. Humidifier connections
  - 17. H<sub>2</sub>O heating coil input Ø 1"1/4 / recovery coil from food refrigeration, input Ø 1"1/4 (optional)
  - 18. H<sub>2</sub>O heating coil outlet Ø 1"1/4 / food refriger. rec. coil outlet Ø 1"1/4 (optional)
  - 19. Outdoor air hood (only with vers. CBK / CBK-G / CCK-REVO) accessory supplied separately
  - 20. Power input
  - 21. Exhaust electric fan
  - 22. Gas module
  - 23. Gas connection
  - 24. Condensate drain (only for condensing module)
- (RO) Horizontal air return  
(R3) Downward air return (optional)  
(MO) Horizontal air supply  
(AE) Outdoor air return (CBK / CBK-G / CCK-REVO version)  
(H1) Wall with same height as unit on a maximum of three sides  
(\*\*) Minimum suggested clearance to remove drain pan (1500mm if drain pan is not necessary to remove)  
(\*) Vibration mounts position

**28.2**

**WEIGHT DISTRIBUTION**

Configuration	CAK	CBK	CBK-G	CCK-REVO	WEIGHT DISTRIBUTION GAS MODULE	
W1 Support point	kg 312	312	316	330	W5 Support point	kg 73
W2 Support point	kg 258	258	262	276	W6 Support point	kg 62
W3 Support point	kg 294	294	298	311	W7 Support point	kg 62
W4 Support point	kg 323	323	327	341	W8 Support point	kg 73
Operation weight	kg 1187	1187	1203	1258	Operation weight	kg 270
Shipping weight	kg 1214	1214	1230	1285	Shipping weight	kg 270

Optional accessories may result in a substantial variation of the weight show in table

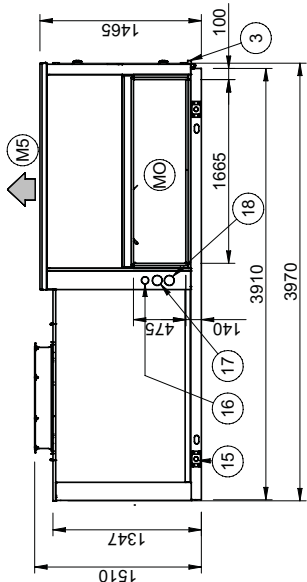
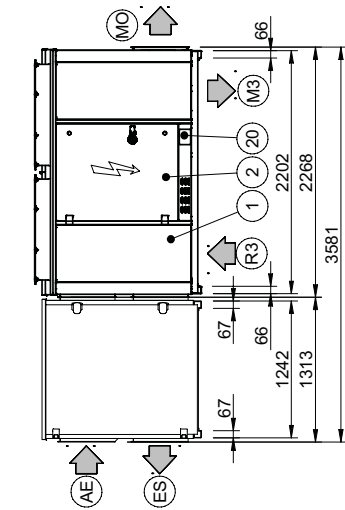
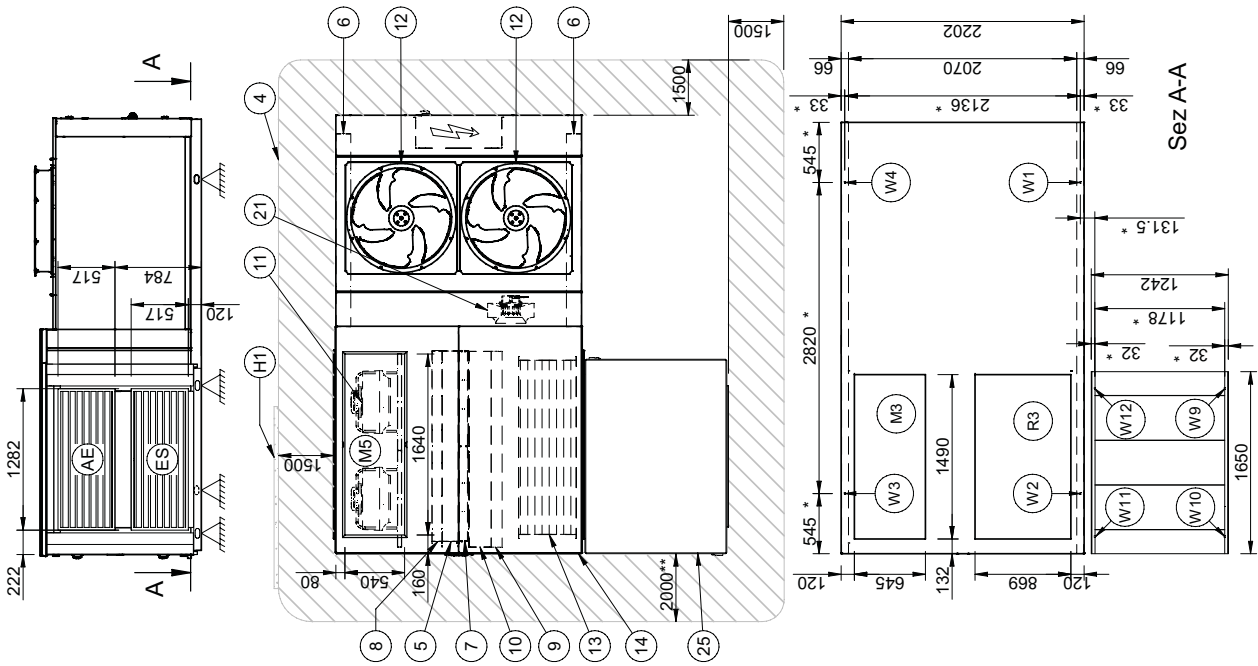

- 19. Outdoor air return cap (Not available with enthalpic wheel)
- 20. Power input
- 21. Exhaust electric fan
- 22. Gas module (Drawing dedicated)
- 23. Gas connection (Drawing dedicated)
- 24. Condensate drain (Drawing dedicated)
- 25. Enthalpy wheel

- 1. Compressor compartment
- 2. Electrical panel
- 3. Condensate drain / Removable drain pan
- 4. Functional clearances
- 5. Internal exchanger
- 6. External exchanger
- 7. H<sub>2</sub>O heating coil / recovery coil from food refrigeration / heating elements (optional)
- 8. Re-heating coil (Optional)
- 9. G4 air filters (Standard)
- 10. F7 / F9 filters / IFD electronics filters (optional)
- 11. Electrical fan (Supply - return)
- 12. External electric fan
- 13. Outdoor air damper (CBK / CBK-G / CCK-REVO Version)
- 14. Access for inspection of coils / filters / heating elements
- 15. Lifting brackets (removable)
- 16. Humidifier connections
- 17. H<sub>2</sub>O heating coil input Ø 1"1/4 / recovery coil from food refrigeration, input Ø 1"1/4 (optional)
- 18. H<sub>2</sub>O heating coil output Ø 1"1/4 / recovery coil from food refrigeration, output Ø 1"1/4 (optional)

**WEIGHT DISTRIBUTION**

Configuration	CBK-G	WEIGHT DISTRIBUTION - ROTARY RECOVERY MODULE
W1 Support point	kg 316	W9 Support point kg 135
W2 Support point	kg 262	W10 Support point kg 135
W3 Support point	kg 298	W11 Support point kg 120
W4 Support point	kg 327	W12 Support point kg 120
Operation weight	kg 1203	Operation weight kg 510
Shipping weight	kg 1230	Shipping weight kg 510

Optional accessories may result in a substantial variation of the weight show in table

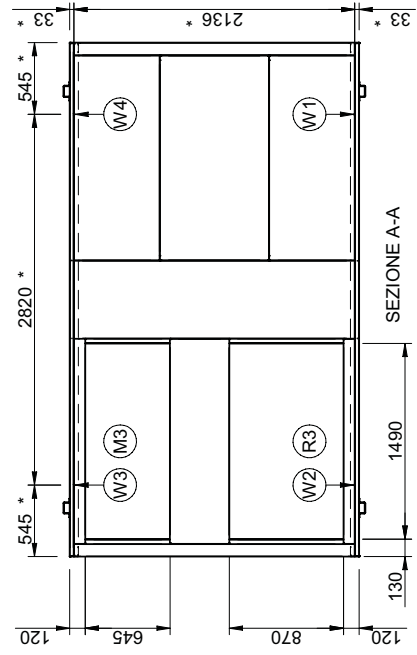
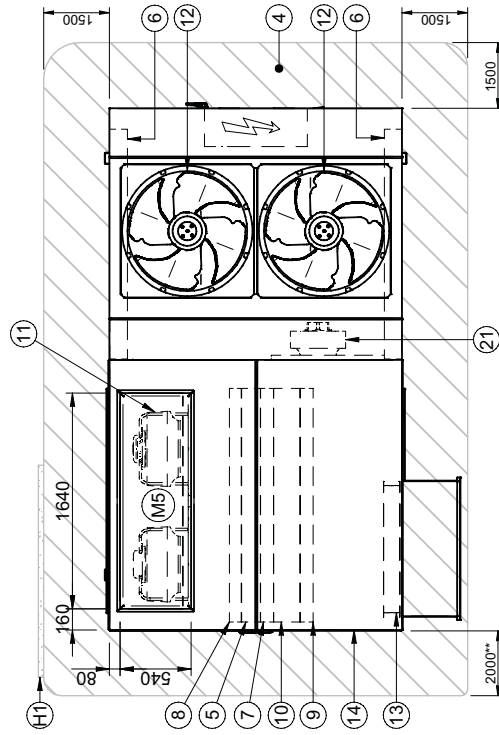
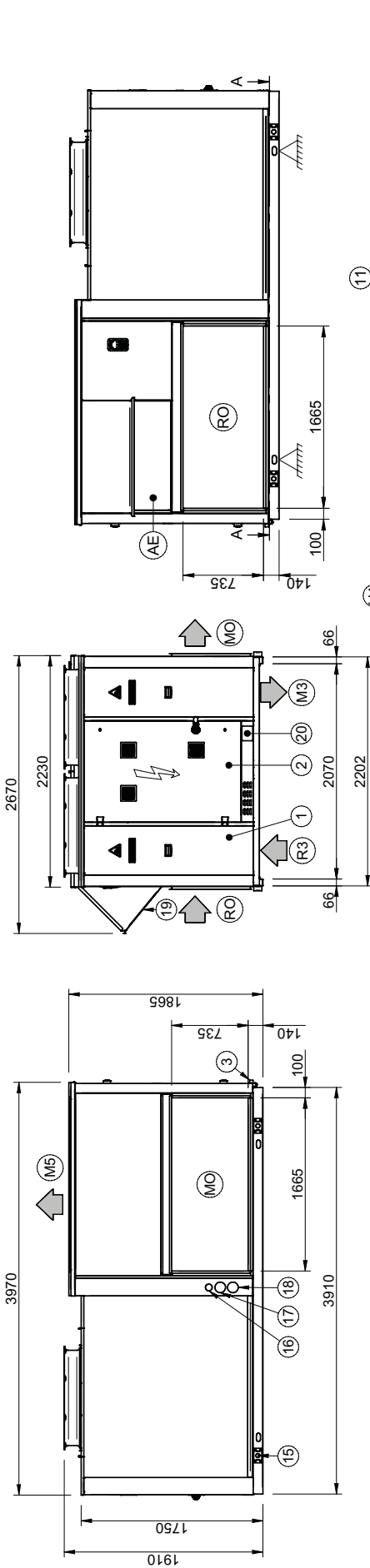

18. H<sub>2</sub>O heating coil output Ø 1"1/4 / recovery coil from food refrigeration, output Ø 1"1/4 (optional)
  19. Outdoor air hood (only with vers. CBK / CBK-G / CCK-REVO) accessory supplied separately
  20. Power input
  21. Exhaust electric fan
- (RO) Horizontal air return  
(R3) Downward air return (optional)  
(MO) Horizontal air supply  
(M3) Air supply from the bottom (optional)  
(M5) Vertical air supply (optional)  
(AE) Outdoor air return (CBK / CBK-G / CCK-REVO version)  
(H1) Wall with same height as unit on a maximum of three sides  
(\*) Vibration mounts position  
(\*\*) Minimum suggested clearance to remove drain pan (500mm if drain pan is not necessary to remove)

1. Compressor compartment
2. Electrical panel
3. Condensate drain / Removable drain pan
4. Functional clearances
5. Internal exchanger
6. External exchanger
7. H<sub>2</sub>O heating coil / recovery coil from food refrigeration / heating elements (optional)
8. Re-heating coil (Optional)
9. G4 air filters (Standard)
10. F7 / F9 filters / iFD electronics filters (optional)
11. Electrical fan (Supply - return)
12. External electric fan
13. Outdoor air damper (CBK / CBK-G / CCK-REVO Version)
14. Access for inspection of coils / filters / heating elements
15. Lifting brackets (removables)
16. Humidifier connections
17. H<sub>2</sub>O heating coil input Ø 1"1/4 / recovery coil from food refrigeration, input Ø 1"1/4 (optional)

40.4

Configuration	CAK	CBK	CBK-G	CCK-REVO
W1 Support point	kg 439	439	448	457
W2 Support point	kg 370	370	379	385
W3 Support point	kg 416	416	425	431
W4 Support point	kg 453	453	462	471
Operation weight	kg 1678	1678	1714	1744
Shipping weight	kg 1717	1717	1753	1784

Optional accessories may result in a substantial variation of the weight show in table

Size 40.4 - CAK / CBK / CBK-G / CCK-REVO + GC09X - GC10X - GC11X Version

DAA800003\_GC09X-GC10X-GC11X\_00  
DATA/DATE 07/06/2022

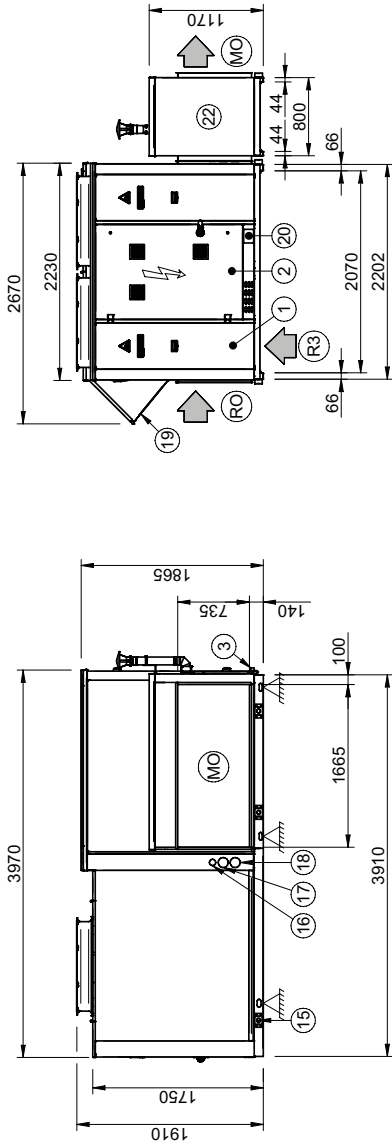
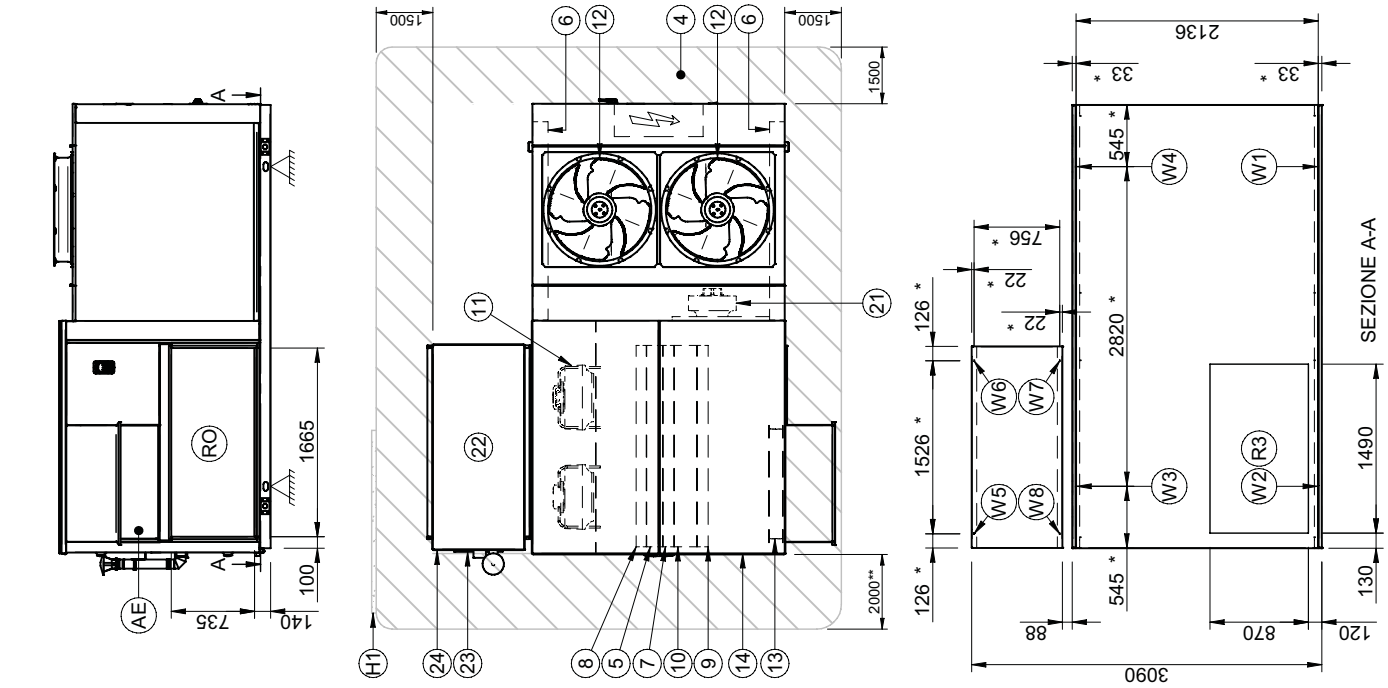

- 1. Compressor compartment
- 2. Electrical panel
- 3. Condensate drain / Removable drain pan
- 4. Functional clearances
- 5. Internal exchanger
- 6. External exchanger
- 7. H<sub>2</sub>O heating coil / recovery coil from food refrigeration / heating elements (optional)
- 8. Re-heating coil (Optional)
- 9. G4 air filters (Standard)
- 10. F7 / F9 filters / FD electronics filters (optional)
- 11. Electrical fan (Supply - return)
- 12. External electric fan
- 13. Outdoor air damper (CBK / CBK-G / CCK-REVO Version)
- 14. Access for inspection of coils / filters / heating elements
- 15. Lifting brackets (removable)
- 16. Humidifier connections
- 17. H<sub>2</sub>O heating coil input Ø 1"1/4 / recovery coil from food refrigeration, input Ø 1"1/4 (optional)
- 18. H<sub>2</sub>O heating coil output Ø 1"1/4 / recovery coil from food refrigeration, output Ø 1"1/4 (optional)
- 19. Outdoor air hood (only with vers. CBK / CBK-G / CCK-REVO) accessory supplied separately
- 20. Power input
- 21. Exhaust electric fan
- 22. Gas module
- 23. Gas connection
- 24. Condensate drain (only for condensing module)

- (RO) Horizontal air return
- (R3) Downward air return (optional)
- (MO) Horizontal air supply
- (AE) Outdoor air return (CBK / CBK-G / CCK-REVO version)
- (H1) Wall with same height as unit on a maximum of three sides
- (\*) Vibration mounts position
- (\*\*) Minimum suggested clearance to remove drain pan (1500mm if drain pan is not necessary to remove)

WEIGHT DISTRIBUTION	40.4			
	CAK	CBK	CBK-G	CCK-REVO
W1 Support point	439	439	448	457
W2 Support point	370	370	379	385
W3 Support point	416	416	425	431
W4 Support point	453	453	462	471
Operation weight	1678	1678	1714	1744
Shipping weight	1717	1717	1753	1784

  

WEIGHT DISTRIBUTION GAS MODULE	
W5 Support point	73
W6 Support point	62
W7 Support point	62
W8 Support point	73
Operation weight	270
Shipping weight	270

Optional accessories may result in a substantial variation of the weight show in table

Size 40.4 - CAK / CBK / CBK-G / CCK-REVO + GC12X Version

DAA800003\_GC12X\_00  
DATA/DATE 07/06/2022

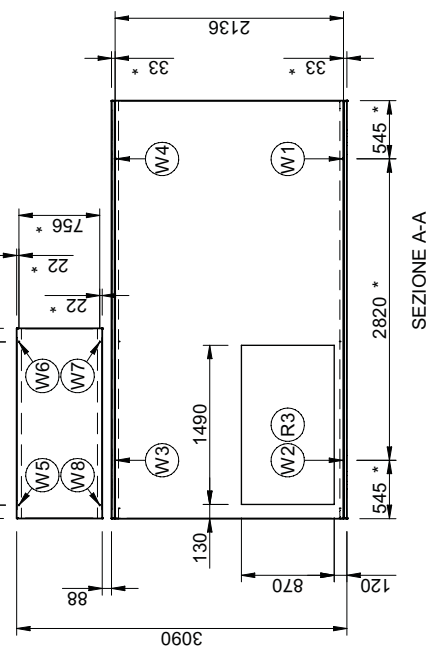
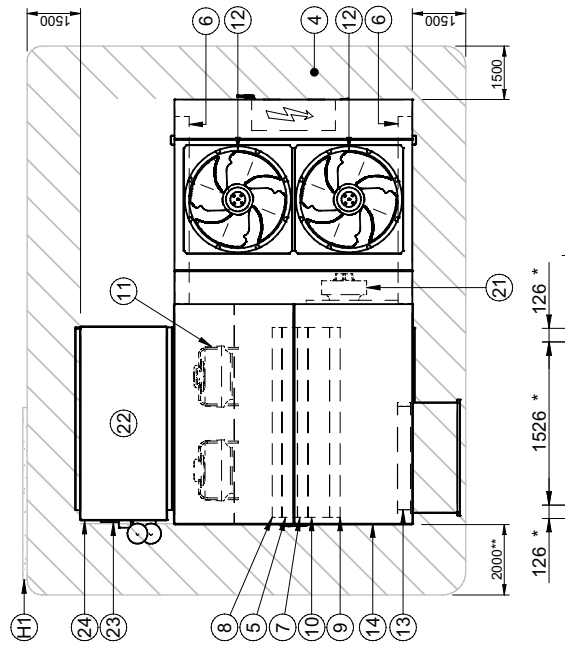
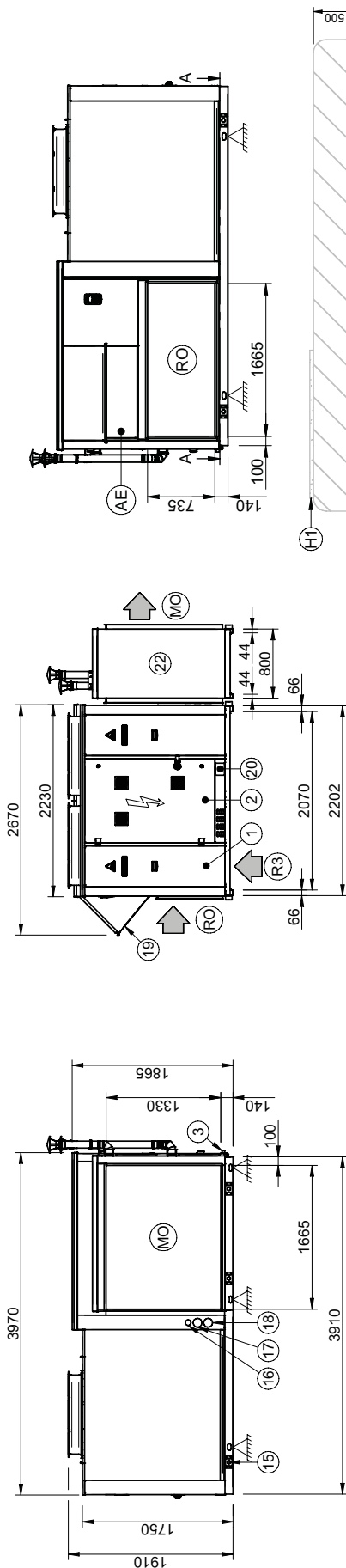

- 1. Compressor compartment
- 2. Electrical panel
- 3. Condensate drain / Removable drain pan
- 4. Functional clearances
- 5. Internal exchanger
- 6. External exchanger
- 7. H2O heating coil / recovery coil from food refrigeration / heating elements (optional)
- 8. Re-heating coil (Optional)
- 9. G4 air filters (Standard)
- 10. F7 / F9 filters / FD electronics filters (optional)
- 11. Electrical fan (Supply - return)
- 12. External electric fan
- 13. Outdoor air damper (CBK / CBK-G / CCK-REVO Version)
- 14. Access for inspection of coils / filters / heating elements
- 15. Lifting brackets (removable)
- 16. Humidifier connections
- 17. H2O heating coil inlet Ø 1"1/4 / food refrig. rec. coil inlet Ø 2" (optional)
- 18. H2O heating coil outlet Ø 1"1/4 / food refrig. rec. coil outlet Ø 2" (optional)
- 19. Outdoor air hood (only with vers. CBK / CBK-G / CCK-REVO) accessory supplied separately
- 20. Power input
- 21. Exhaust electric fan
- 22. Gas module
- 23. Gas connection
- 24. Condensate drain (only for condensing module)

- (RO) Horizontal air return
- (R3) Downward air return (optional)
- (MO) Horizontal air supply
- (AE) Outdoor air return (CBK / CBK-G / CCK-REVO version)
- (H1) Wall with same height as unit on a maximum of three sides
- (\*\*) Minimum suggested clearance to remove drain pan (1500mm if drain pan is not necessary to remove)
- (\*) Vibration mounts position

WEIGHT DISTRIBUTION  
SIZE 40.4

Configuration	CAK	CBK	CBK-G	CCK-REVO	WEIGHT DISTRIBUTION GAS MODULE
W1 Support point	kg 439	kg 439	kg 448	kg 457	W5 Support point kg 90
W2 Support point	kg 370	kg 370	kg 379	kg 385	W6 Support point kg 78
W3 Support point	kg 416	kg 416	kg 425	kg 431	W7 Support point kg 78
W4 Support point	kg 453	kg 453	kg 462	kg 471	W8 Support point kg 90
Operation weight	kg 1678	kg 1678	kg 1714	kg 1744	Operation weight kg 336
Shipping weight	kg 1717	kg 1717	kg 1753	kg 1784	Shipping weight kg 336

Optional accessories may result in a substantial variation of the weight show in table





Size 56.4 - CAK / CBK / CBK-G / CCK-REVO Version

DAA800004\_00  
DATA/DATE 06/06/2022

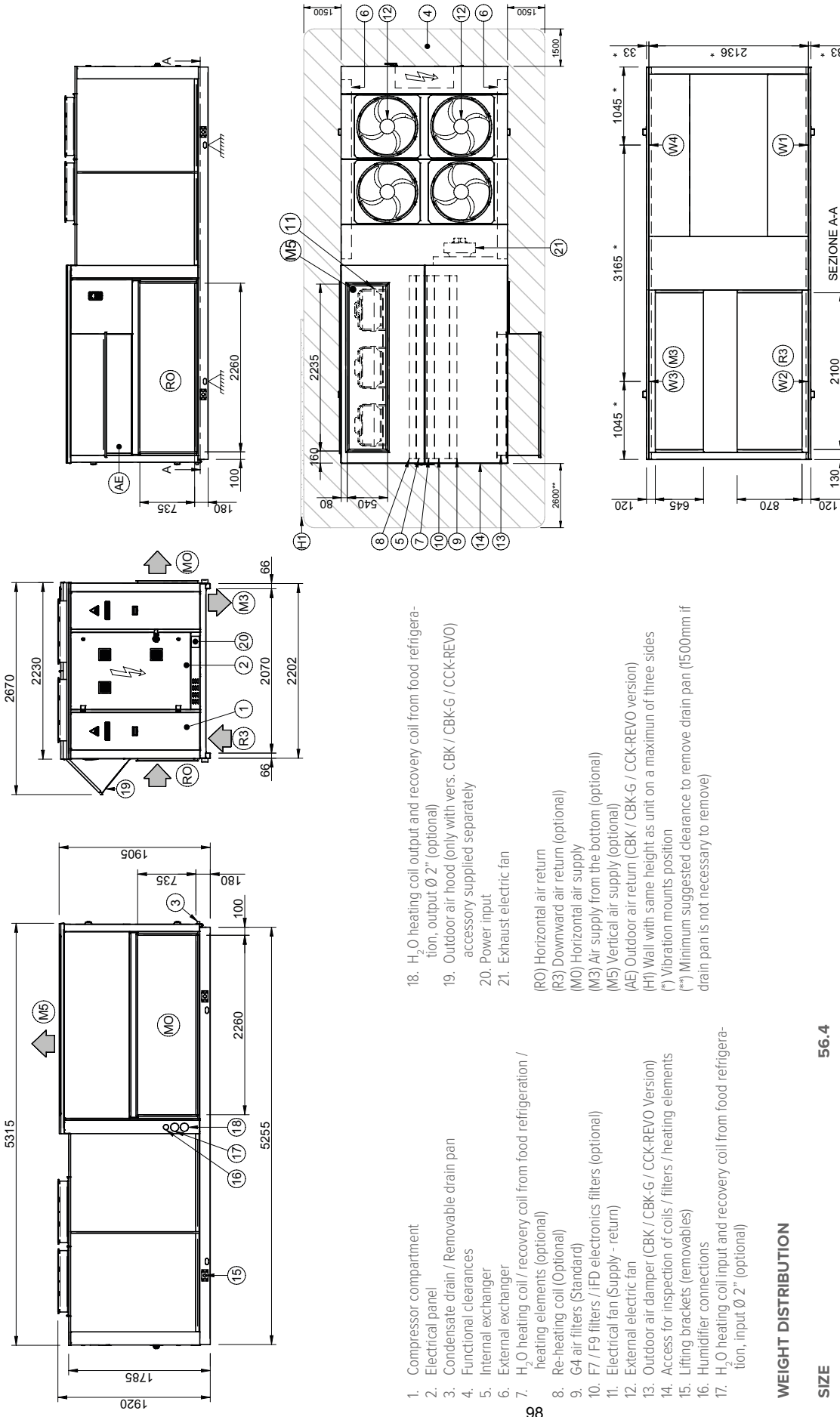

1. Compressor compartment
  2. Electrical panel
  3. Condensate drain / Removable drain pan
  4. Functional clearances
  5. Internal exchanger
  6. External exchanger
  7. H<sub>2</sub>O heating coil / recovery coil from food refrigeration / heating elements (optional)
  8. Re-heating coil (Optional)
  9. G4 air filters (Standard)
  10. F7 / F9 filters / IFD electronics filters (optional)
  11. Electrical fan (Supply - return)
  12. External electric fan
  13. Outdoor air damper (CBK / CBK-G / CCK-REVO Version)
  14. Access for inspection of coils / filters / heating elements
  15. Lifting brackets (removable)
  16. Humidifier connections
  17. H<sub>2</sub>O heating coil input and recovery coil from food refrigeration, input Ø 2" (optional)
  18. H<sub>2</sub>O heating coil output and recovery coil from food refrigeration, output Ø 2" (optional)
  19. Outdoor air hood (only with vers. CBK / CBK-G / CCK-REVO) accessory supplied separately
  20. Power input
  21. Exhaust electric fan
- (RO) Horizontal air return  
(R3) Downward air return (optional)  
(M0) Horizontal air supply  
(M3) Air supply from the bottom (optional)  
(M5) Vertical air supply (optional)  
(AE) Outdoor air return (CBK / CBK-G / CCK-REVO version)  
(H1) Wall with same height as unit on a maximum of three sides  
(\*) Vibration mounts position  
(\*\*) Minimum suggested clearance to remove drain pan (1500mm if drain pan is not necessary to remove)

**WEIGHT DISTRIBUTION**

**56.4**

Configuration	CAK	CBK	CBK-G	CCK-REVO
W1 Support point	kg 601	601	613	625
W2 Support point	kg 506	506	518	527
W3 Support point	kg 569	569	581	590
W4 Support point	kg 620	620	632	644
Operation weight	kg 2296	2296	2345	2386
Shipping weight	kg 2349	2349	2398	2441

Optional accessories may result in a substantial variation of the weight show in table

Size 56.4 - CAK / CBK / CBK-G / CCK-REVO + GC10X - GC11X Version

DAA80004\_GC10X-GC11X\_00  
DATA/DATE 06/06/2022

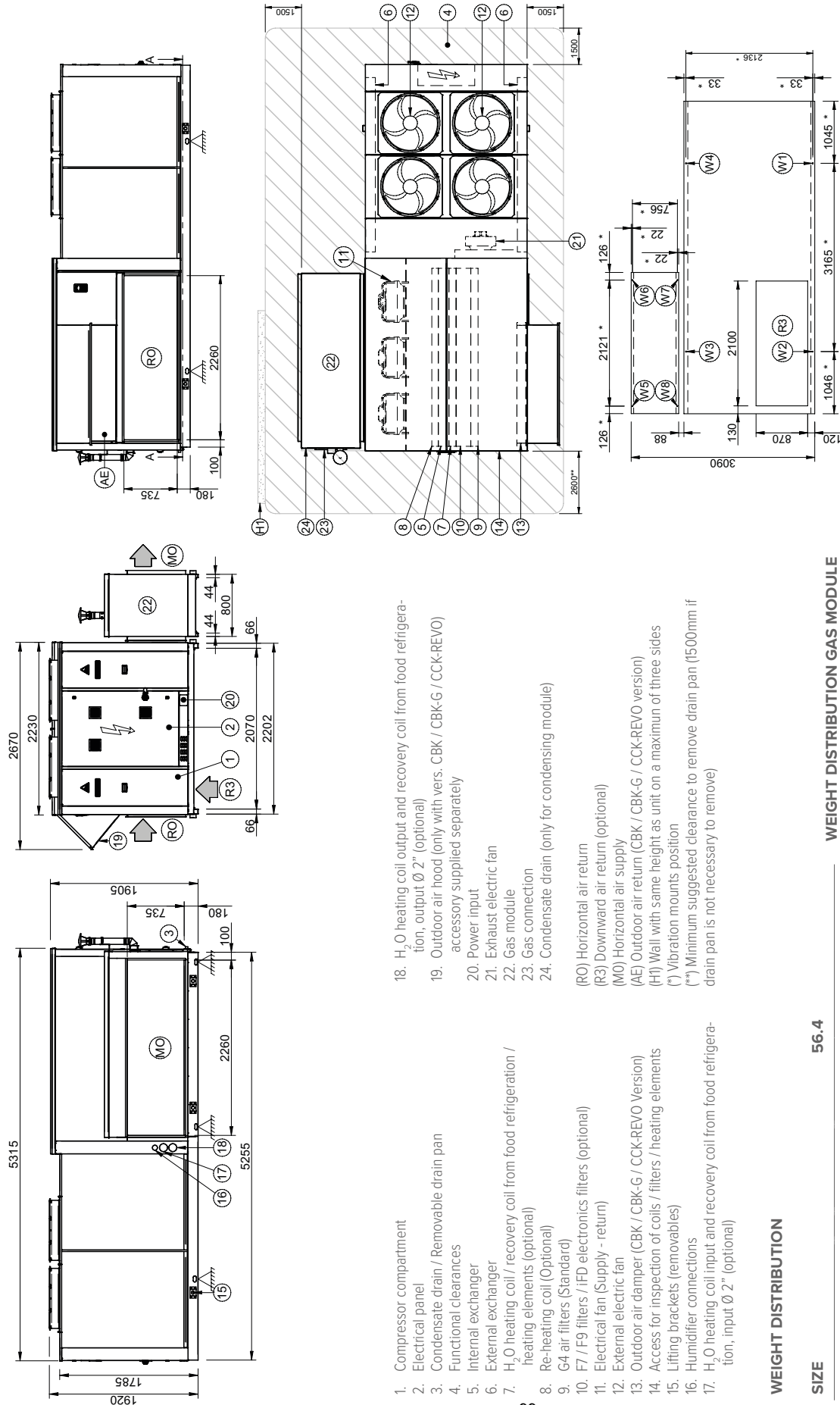

- 1. Compressor compartment
- 2. Electrical panel
- 3. Condensate drain / Removable drain pan
- 4. Functional clearances
- 5. Internal exchanger
- 6. External exchanger
- 7. H<sub>2</sub>O heating coil / recovery coil from food refrigeration / heating elements (optional)
- 8. Re-heating coil (Optional)
- 9. G4 air filters (Standard)
- 10. F7 / F9 filters / FD electronics filters (optional)
- 11. Electrical fan (Supply - return)
- 12. External electric fan
- 13. Outdoor air damper (CBK / CBK-G / CCK-REVO Version)
- 14. Access for inspection of coils / filters / heating elements
- 15. Lifting brackets (removable)
- 16. Humidifier connections
- 17. H<sub>2</sub>O heating coil input and recovery coil from food refrigeration, input Ø 2" (optional)
- 18. H<sub>2</sub>O heating coil output and recovery coil from food refrigeration, output Ø 2" (optional)
- 19. Outdoor air hood (only with vers. CBK / CBK-G / CCK-REVO) accessory supplied separately
- 20. Power input
- 21. Exhaust electric fan
- 22. Gas module
- 23. Gas connection
- 24. Condensate drain (only for condensing module)

**WEIGHT DISTRIBUTION GAS MODULE**

W5 Support point	kg	73
W6 Support point	kg	62
W7 Support point	kg	62
W8 Support point	kg	73
Operation weight	kg	270
Shipping weight	kg	270

**WEIGHT DISTRIBUTION**

Configuration	CAK	CBK	CBK-G	CCK-REVO
W1 Support point	kg	601	613	625
W2 Support point	kg	506	518	527
W3 Support point	kg	569	581	590
W4 Support point	kg	620	632	644
Operation weight	kg	2296	2345	2386
Shipping weight	kg	2349	2398	2441

Optional accessories may result in a substantial variation of the weight show in table

Size 56.4 - CAK / CBK / CBK-G / CCK-REVO + GC12X - GC13X Version

DAA80004\_GC12X-GC13  
DATA/DATE 06/06/2022

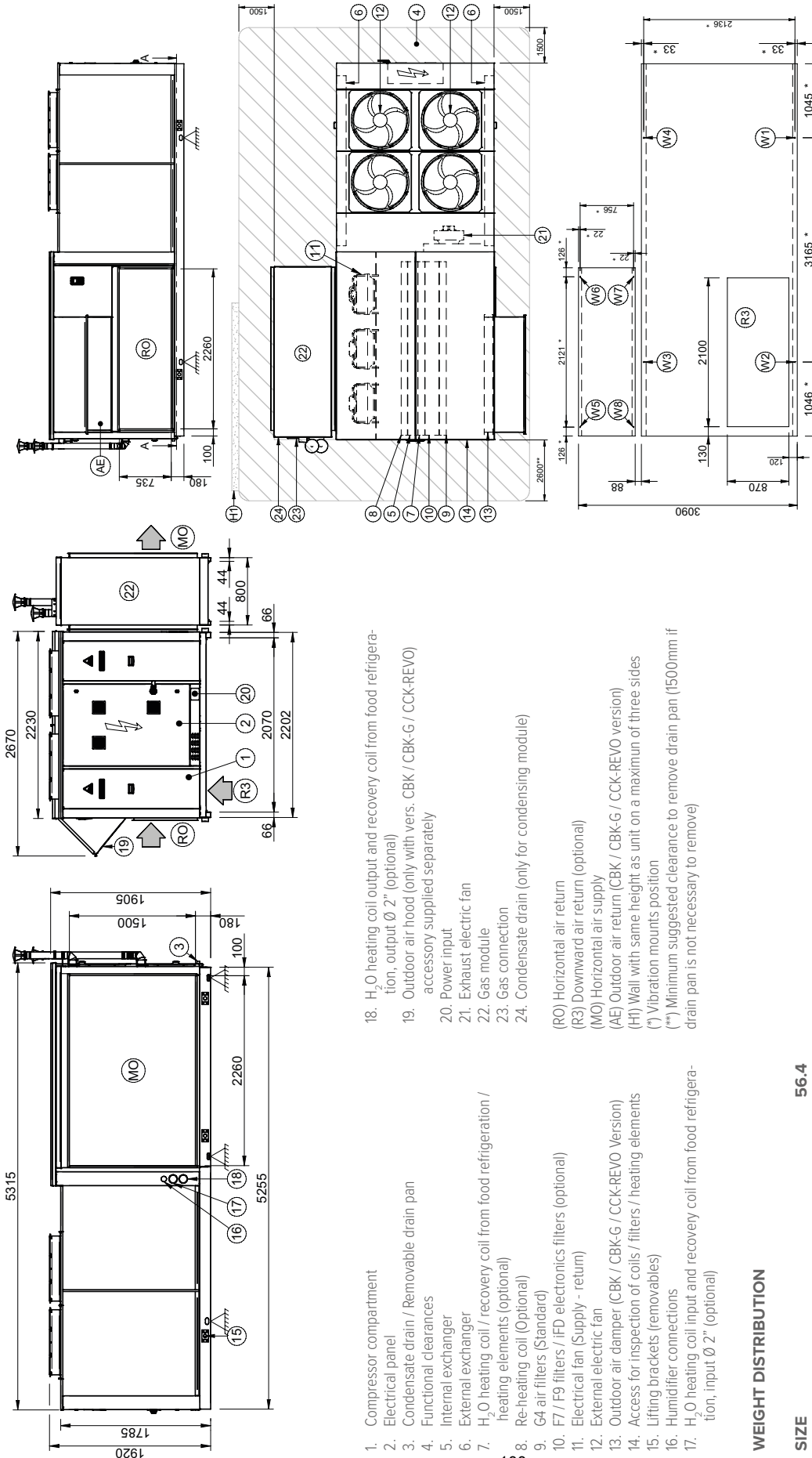

- 1. Compressor compartment
- 2. Electrical panel
- 3. Condensate drain / Removable drain pan
- 4. Functional clearances
- 5. Internal exchanger
- 6. External exchanger
- 7. H<sub>2</sub>O heating coil / recovery coil from food refrigeration / heating elements (optional)
- 8. Re-heating coil (Optional)
- 9. G4 air filters (Standard)
- 10. F7 / F9 filters / IFD electronics filters (optional)
- 11. Electrical fan (Supply - return)
- 12. External electric fan
- 13. Outdoor air damper (CBK / CBK-G / CCK-REVO Version)
- 14. Access for inspection of coils / filters / heating elements
- 15. Lifting brackets (removable)
- 16. Humidifier connections
- 17. H<sub>2</sub>O heating coil input and recovery coil from food refrigeration, input Ø 2" (optional)
- 18. H<sub>2</sub>O heating coil output and recovery coil from food refrigeration, output Ø 2" (optional)
- 19. Outdoor air hood (only with vers. CBK / CBK-G / CCK-REVO accessory supplied separately)
- 20. Power input
- 21. Exhaust electric fan
- 22. Gas module
- 23. Gas connection
- 24. Condensate drain (only for condensing module)

**56.4**

Configuration	CAK	CBK	CBK-G	CCK-REVO	WEIGHT DISTRIBUTION GAS MODULE
W1 Support point	601	601	613	625	W5 Support point kg 145
W2 Support point	506	506	518	527	W6 Support point kg 100
W3 Support point	569	569	581	590	W7 Support point kg 100
W4 Support point	620	620	632	644	W8 Support point kg 145
Operation weight	2296	2296	2345	2386	Operation weight kg 490
Shipping weight	2349	2349	2398	2441	Shipping weight kg 490

**WEIGHT DISTRIBUTION**

**56.4**

Optional accessories may result in a substantial variation of the weight show in table

# Size 56.4 - CBK-G Version + Rotary recovery module

DAA80004\_RE\_00  
DATA/DATE 30/08/2022

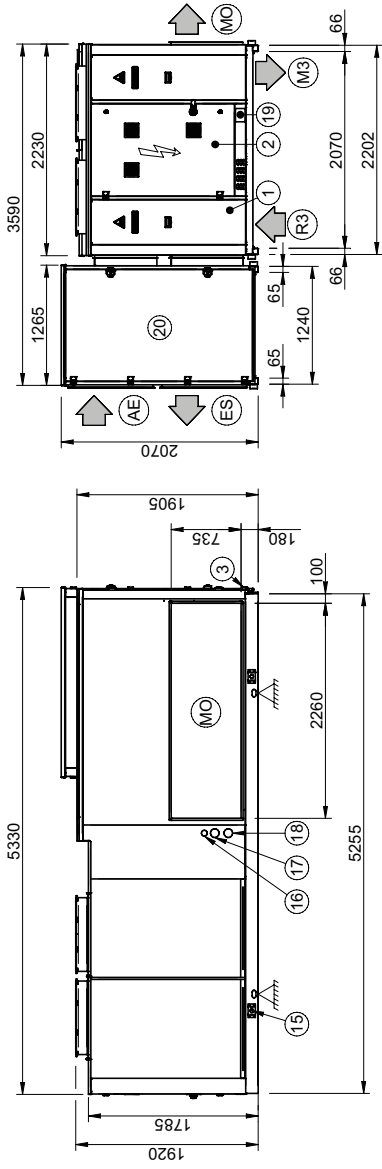
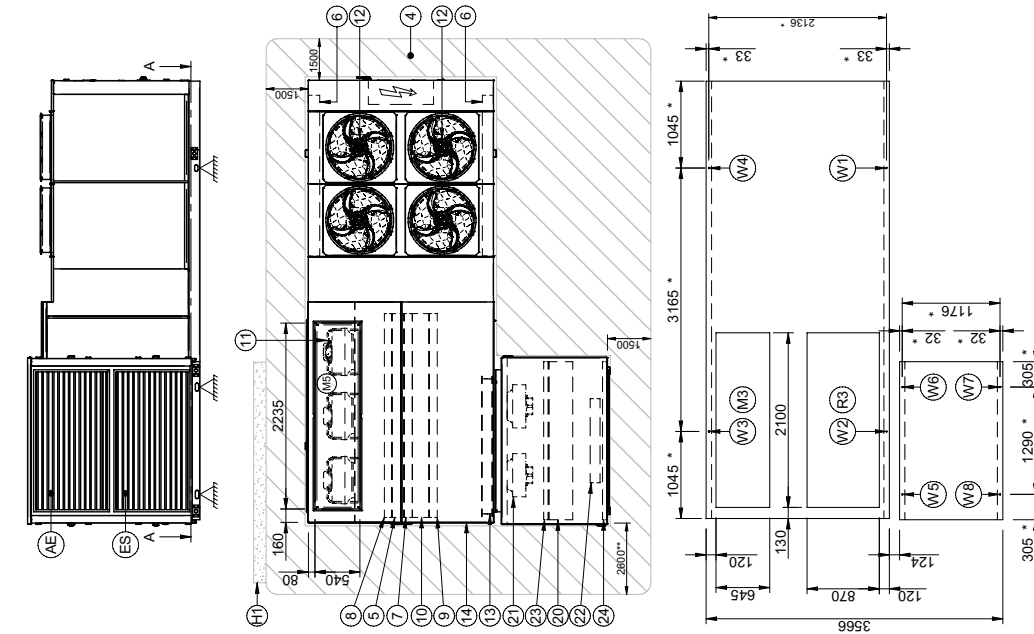

1. Compressor compartment
2. Electrical panel
3. Condensate drain / Removable drain pan
4. Functional clearances
5. Internal exchanger
6. External exchanger
7. H<sub>2</sub>O heating coil / recovery coil from food refrigeration / heating elements (optional)
8. Re-heating coil (Optional)
9. G4 air filters (Standard)
10. F7 / F9 filters / IFD electronics filters (optional)
11. Electrical fan (Supply - return)
12. External electric fan
13. Outdoor air damper / air expulsion
14. Access for inspection of coils / filters / heating elements
15. Lifting brackets (removable)
16. Humidifier connections
17. H<sub>2</sub>O heating coil input and recovery coil from food refrigeration, input Ø 2" (optional)
18. H<sub>2</sub>O heating coil output and recovery coil from food refrigeration, output Ø 2" (optional)
19. Power input
20. Rotary recovery module
21. Exhaust electric fan
22. Air expulsion damper
23. G4 air filters (espulsione)
24. G4 air filters (outdoor air return)
- (R3) Downward air return (optional)
- (MO) Horizontal air supply
- (M3) Downward air supply (optional)
- (M5) Vertical air supply (optional)
- (AE) Outdoor air return (CBK / CBK-G / CCK-REVO version)
- (H1) Wall with same height as unit on a maximum of three sides
- (\*) Vibration mounts position
- (\*\*) Minimum suggested clearance to remove drain pan (1500mm if drain pan is not necessary to remove)

## WEIGHT DISTRIBUTION

SIZE	56.4	WEIGHT DISTRIBUTION - ROTARY RECOVERY MODULE
Configuration	CBK-G	
W1 Support point	kg	613
W2 Support point	kg	518
W3 Support point	kg	581
W4 Support point	kg	632
Operation weight	kg	2345
Shipping weight	kg	2398
W5 Support point	kg	173
W6 Support point	kg	162
W7 Support point	kg	141
W8 Support point	kg	154
Operation weight	kg	630
Shipping weight	kg	645

Optional accessories may result in a substantial variation of the weight show in table





FOR OVER 35 YEARS, WE HAVE BEEN  
OFFERING SOLUTIONS TO ENSURE  
SUSTAINABLE COMFORT AND THE  
WELL-BEING OF PEOPLE AND THE  
ENVIRONMENT



sales and assistance

Info & Contacts: [www.clivet.com](http://www.clivet.com)

