



# OUTDOOR UNIT VRF

CVT8-X 252T-900T Series

**MANUAL**  
FOR INSTALLATION,  
USE AND MAINTENANCE



MOV800002-00

# CONTENTS

---

<b>OWNER'S MANUAL</b> .....	01
<b>1 OVERVIEW</b> .....	01
• 1.1 Meaning of Various Labels .....	01
<b>2 SYSTEM INFORMATION</b> .....	01
<b>3 USER INTERFACE</b> .....	01
<b>4 BEFORE OPERATING</b> .....	01
<b>5 OPERATIONS</b> .....	02
• 5.1 Operating Range .....	02
• 5.2 Operating System .....	02
• 5.3 Dry Program .....	03
<b>6 MAINTENANCE AND REPAIR</b> .....	03
• 6.1 Maintenance After the Unit Has Been Shut Down for a Long Period .....	04
• 6.2 Maintenance Before the Unit Is Shut Down for a Long Period .....	04
• 6.3 About the Refrigerant .....	04
• 6.4 After-sales Service and Warranty .....	04
<b>7 TROUBLESHOOTING</b> .....	05
• 7.1 Error Code: Overview .....	06
• 7.2 Fault Symptom: Non Air Conditioning Issues .....	09
<b>8 CHANGING INSTALLATION SITE</b> .....	09
<b>9 DISPOSAL</b> .....	09
<b>INSTALLATION MANUAL</b> .....	10
<b>1 OVERVIEW</b> .....	10
• 1.1 Notice to Installation Personnel .....	10
• 1.2 Notice to Users .....	12
<b>2 PACKING BOX</b> .....	12
• 2.1 Overview .....	12
• 2.2 Unboxing the Outdoor Unit .....	13
• 2.3 Taking Out Accessories of Outdoor Unit .....	13
• 2.4 Pipe Fittings .....	15

<b>3</b>	<b>OUTDOOR UNIT COMBINATION</b>	15
•	3.1 Overview	15
•	3.2 Branch Joints	15
•	3.3 Recommended Outdoor Unit Combination	15
<b>4</b>	<b>PREPARATIONS BEFORE INSTALLATION</b>	18
•	4.1 Overview	18
•	4.2 Choosing and Preparing the Installation Site	18
•	4.3 Selecting and Preparing the Refrigerant Piping	20
•	4.4 Selecting and Preparing the Electrical Wiring	28
<b>5</b>	<b>OUTDOOR UNIT INSTALLATION</b>	29
•	5.1 Overview	29
•	5.2 Opening the Unit	29
•	5.3 Installing the Outdoor Unit	31
•	5.4 Pipe Welding	33
•	5.5 Flushing Pipes	35
•	5.6 Gas Tightness Test	36
•	5.7 Vacuum Drying	37
•	5.8 Piping Insulation	37
•	5.9 Refrigerant Charging	38
•	5.10 Electrical Wiring	39
<b>6</b>	<b>CONFIGURATION</b>	48
•	6.1 Overview	48
•	6.2 Digital Display and Button Settings	48
<b>7</b>	<b>COMMISSIONING</b>	54
•	7.1 Overview	54
•	7.2 Things to Note During Test Run	54
•	7.3 Checklist Before Test Run	54
•	7.4 About Test Run	55
•	7.5 Test Run Implementation	55
•	7.6 Rectifications After Test Run Is Completed with Exceptions	56
•	7.7 Operating This Unit	56
<b>8</b>	<b>MAINTENANCE AND REPAIR</b>	56
•	8.1 Overview	56
•	8.2 Safety Precautions for Maintenance	56
<b>9</b>	<b>TECHNICAL DATA</b>	57
•	9.1 Dimensions	57
•	9.2 Component Layout and Refrigerant Circuits	58
•	9.3 Outdoor Unit Ducting	61
•	9.4 Fan Performance	62

# OWNER'S MANUAL

## 1 OVERVIEW

### 1.1 Meaning of Various Labels

This document contains important precautions and things to note. Please read them carefully.

#### WARNING

A situation that may lead to severe injury or death.

#### CAUTION

A situation that may lead to mild or moderate injury.

#### NOTE

A situation that may cause damage to the equipment or loss of property.

#### INFORMATION

Indicates a useful hint or additional information.

## 2 SYSTEM INFORMATION

#### INFORMATION

The equipment must be operated by professionals or trained people and is mainly used for commercial purposes such as in stores, shopping malls, and large office buildings.

This unit can be used for heating/cooling.

#### NOTE

- Do not use the air conditioning system for other purposes. To avoid quality degradation, do not use the unit to cool precision instruments, food, plants, animals, or works of art.
- For system maintenance and expansion, please contact professional staff.

## 3 USER INTERFACE

#### CAUTION

- Please contact an agent if you need to check and adjust the internal components.
- The figure shown in this manual is for reference purposes only and may be slightly different from the actual product.

This operation manual only provides information on the main functions of this system.

## 4 BEFORE OPERATING

#### WARNING

- This unit consists of electrical components and hot parts (danger of electric shock and scalding).
- Before you operate this unit, make sure that the installation personnel have installed it properly.
- This appliance is not intended for use by persons (including children) with reduced physical, sensory or mental capabilities, or who lack experience and knowledge, unless they are supervised or given instructions concerning use of the appliance by a person responsible for their safety.
- Children should be supervised to ensure that they do not play with the appliance.

#### CAUTION

- The air outlet should not directly face someone as it is not healthy to be exposed to long periods of moving cold/hot air.
- If the air conditioner is used together with a device that comes with a burner, make sure the room is fully ventilated to prevent anoxia (oxygen insufficiency).
- Do not operate the air conditioner when applying fumigant insecticide in the room. This may cause chemicals to be deposited inside the unit, and could pose a danger to the health of people who are allergic to chemicals. This unit should only be serviced and maintained by a professional air conditioning service engineer. Incorrect servicing or maintenance can cause electric shock, fire or leakage of water. Contact your dealer for servicing and maintenance.
- The A-weighted sound pressure level of all the units is below 70 dB.
- Cleaning and user maintenance shall not be done by children without supervision.
- The appliance shall be installed in accordance with national wiring regulations.
- This appliance is intended for domestic use and to be used by expert or trained users in shops, in light industry and on farms, or for commercial use by lay persons.

This operation manual is intended for air conditioning systems with standard controls. Before you start the system, please contact an agent for precautions when operating the system. If the installed unit has a custom control system, please ask the agent for information about operating precautions. Operating modes of the outdoor unit (depends on the indoor unit):

- Heating and cooling.
- Fan-only operation.

Specialized functions vary depending on the type of indoor unit. Refer to the installation/user manuals for more information.

- The unit is marked with the following symbols:



This symbol indicates that electrical and electronic products must not be mixed with unsorted household waste. Do not attempt to dismantle the system on your own. All work that involves dismantling the system, and handling the refrigerant, oil, or other components must be carried out by authorized installation personnel, and the work must be carried out in accordance with applicable laws. The unit must be disposed of and treated at special treatment facilities for reuse and recycling. By making sure that this product is properly handled and disposed of, you help to minimize the negative impact on the environment and human health. For more information, please contact the installation personnel or local organization.

## 5 OPERATIONS

### 5.1 Operating Range

Table 5.1

IDU type	Common indoor unit		Fresh processing air indoor unit	
	Cooling mode	Heating mode	Cooling mode	Heating mode
Outdoor temperature	-15-55°C	-30-30°C	20-43°C	-5-16°C
Indoor temperature	16-32°C	15-30°C		
Indoor humidity	≤80% <sup>(a)</sup>			

(a) Condensate might form on the unit's surface if the humidity is above 80%

#### NOTE

The safety device will be triggered if the temperature or humidity exceeds these conditions, and the air conditioner may not run.

## 5.2 Operating System

### 5.2.1 System operations

The operating program varies with different combinations of outdoor unit and controller.

To protect this unit, please turn on the main power supply 12 hours before you start to operate this unit.

If there is a power outage while the unit is running, the unit will automatically restart its operation when the power supply resumes.

### 5.2.2 Cooling, heating, fan only and, auto operations

The indoor units in the air conditioner can be controlled separately, but the indoor units in the same system cannot operate in the heating and cooling modes at the same time.

When the cooling and heating modes conflict, the mode is determined based on the setting of the "Menu mode" of the outdoor unit.

Table 5.2

Automatic priority mode	Automatic selection of heating or cooling priority based on the ambient temperature.
Cooling priority mode	When you select the cooling mode as the priority mode, the heating operations of the indoor unit stop running, while the cooling mode will operate as usual;
No.63 (VIP indoor unit) + voting priority mode	If the indoor unit 63 has been set and turned on, the operating mode of unit 63 will be regarded as the priority operating mode of the system. If the indoor unit 63 has not been set or not turned on, the mode that the majority of indoor units are currently using will be the priority operating mode of the system.
In response to heating only mode	Indoor units which are set to heating mode will operate normally, while indoor units in the cooling or fan mode will display the "E0 mode conflict error". (V8 series indoor unit will not display this error)
In response to cooling only mode	Indoor units which are set to cooling and fan modes will operate normally, while indoor units in the heating mode will display the "E0 mode conflict error". (V8 series indoor unit will not display this error)
Heating priority mode	Indoor units which are set to cooling or fan mode will stop running, while indoor units in the heating mode will run as usual.
Change over	Only applicable to V8 series indoor unit, must set the No.63 (VIP indoor unit). The operation mode of non-VIP indoor units cannot be selected by the wired controller even if the outdoor unit is not running.
Voting priority mode	The mode that the majority of indoor units are currently using will be the priority operating mode of the system.
First on priority mode	The operating mode of the first running Indoor unit will be regarded as the priority operating mode of the system.
Capability requirements priority mode	The mode of the indoor unit that is running to meet the most demands at a point in time is adopted as a priority mode of the system.

### 5.2.3 Heating operations

Heating usually takes longer than cooling.

Perform the following operations to prevent the heating capacity from dropping or to prevent the system from outputting cold air.

#### Defrost operation

While heating is in use, as the outdoor temperature decreases, frost may form on the heat exchanger in the outdoor unit, making it more difficult for the heat exchanger to heat the air. This decreases the heating capacity, and the system will need to be defrosted to provide sufficient heat to the indoor unit. At this point, the indoor unit's display screen will show the defrost operation.

The indoor fan motor will automatically stop running to prevent cold air from coming out of the indoor unit when heating begins. This process will take some time. This is not a malfunction.

#### INFORMATION

- When there is a drop in the external temperature, the heating capacity decreases. If this happens, please use another heating device and the unit at the same time. (Make sure the room is well ventilated if you are using equipment that produces fire.) Do not place any equipment that may produce a flame where the air outlets of the unit are or below the unit itself.
- Once the unit starts, it takes some time for the room temperature to rise, as the unit uses a hot air circulation system to heat the room.
- If the hot air rises to the ceiling, causing the ground area to become cold, it is recommended that you use a circulating device (to circulate the indoor air). Please contact the agent for details.

### 5.2.4 Operating system

1. Press the "switch" button on the controller.  
Result: The running light turns on and the system starts to operate.

2. Repeatedly press the mode selector on the controller to select the required operation mode.

#### Stop

Press the "switch" button on the controller again.  
Result: The running light is now off, and the system stops running.

#### NOTE

Once the unit has stopped running, do not disconnect the power immediately. Wait for at least 10 minutes.

#### Adjust

Refer to the controller user manual for information about how to set the required temperature, fan speed and air flow direction.

## 5.3 Dry Program

### 5.3.1 System operations

The function of this program uses the minimum temperature drop (minimum indoor cooling) to lower the humidity in the room.

In the drying process, the system automatically determines the temperature and fan speed (the settings cannot be implemented through the user interface).

### 5.3.2 Dry operations

#### Start

1. Press the switch button on the controller.  
Result: The running light turns on and the system starts operating.

2. Repeatedly press the mode selector on the controller.

3. Press the button to adjust the air flow direction (this function is not available for all indoor units).

#### Stop

4. Press the switch button on the user interface again.  
Result: The running light is now off, and the system has stopped running.

#### WARNING

Do not touch the air outlet or the horizontal blade when the fan is operating in swing mode. Your fingers could become caught in the unit or the unit could be damaged.

## 6 MAINTENANCE AND REPAIR

#### NOTE

- Do not check or repair the unit on your own. Please get qualified professionals to conduct any checks or repairs.
- Do not use substances like gasoline, diluent, or chemical dust cloths to wipe the operations panel of the controller. Doing so could remove the surface layer of the controller. If the unit is dirty, immerse a cloth in diluted and neutral detergent, wring it out, and then use it to clean the panel. Lastly, wipe it with a dry cloth.

## WARNING

- When the fuse melts, do not use any unspecified fuses or other wires to replace the original fuse. The use of electrical wires or copper wires may cause the unit to malfunction or cause a fire.
- Do not insert your fingers, sticks, or other items into the air inlet or outlet. Do not remove the fan mesh cover. When the fan rotates at a high speed, it could cause bodily injury.
- It is very dangerous to check the unit when the fan is rotating.
- Make sure you turn off the main switch before any maintenance work begins.
- Check the supporting and base structure of the unit for any damages after a long period of use. The unit could fall and cause personal injury if there is any damage.

## 6.1 Maintenance After the Unit Has Been Shut Down for a Long Period

For example, in early summer or winter.

- Check for and remove all objects that could clog the air inlets and outlets of the indoor and outdoor units.
- Clean the air filter and external shell of the unit. Please contact the installation or maintenance personnel. The installation/operation manual of the indoor unit includes maintenance tips and cleaning procedures. Make sure that the clean air filter is installed in its original position.
- Turn on the main power supply 12 hours before operating this unit to ensure that the unit runs smoothly. The user interface is displayed once the power is turned on.

## 6.2 Maintenance Before the Unit Is Shut Down for a Long Period

For example, at the end of winter and summer.

- Run the indoor unit in the fan mode for about half a day to dry the internal parts of the unit.
- Turn off the power supply.
- Clean the air filter and external shell of the unit. Contact the installation or maintenance personnel to clean the air filter and external shell of the indoor unit. The installation/operation manual of the specialized indoor unit includes maintenance tips and cleaning procedures. Make sure that the clean air filter is installed in its original position.

## 6.3 About the Refrigerant

This product contains fluorinated greenhouse gases as stipulated in the Kyoto Protocol. Do not discharge the gas into the atmosphere.

Refrigerant Type: R410A

GWP Value: 2088

Based on the applicable law, the refrigerant must be checked regularly for leakages. Please contact the installation personnel for more information.

## WARNING

- The refrigerant in the air conditioner is relatively safer and usually does not leak. If the refrigerant leaks, and comes in contact with an open flame, it will produce harmful gases.
- Shut down any heating devices which produce flame, ventilate the room and contact the agent of the unit immediately.
- Do not use the air conditioner again until the maintenance personnel has confirmed that the refrigerant leakage has been sufficiently resolved.

## 6.4 After-sales Service and Warranty

### 6.4.1 Warranty period

This product contains the warranty card that was completed by the agent during installation. The customer must check the completed warranty card and retain it properly.

If you need to repair the air conditioner during the warranty period, please contact the agent and provide the warranty card.

### 6.4.2 Recommended maintenance and inspection

Using the unit for many years will eventually cause a dust layer to develop, which will cause the performance of the unit to degenerate to a certain extent.

As professional skills are needed to dismantle and clean the unit, and to ensure optimal maintenance of this unit, please contact your agent for more details.

When you request the agent for assistance, please remember to state:

- The complete model name of the air conditioner.
- Date of installation.
- Details of the fault symptoms or errors, and any defects.

## WARNING

- Do not attempt to modify, dismantle, remove, reinstall or repair this unit, as the improper dismantling or installation may result in electric shock or fire. Please contact an agent.
- If the refrigerant accidentally leaks, make sure that there is no open flame around the unit. The refrigerant itself is completely safe, non-toxic and non-flammable, but it will produce toxic gases when it accidentally leaks and comes in contact with flames generated by existing heaters, and burning devices in the room. Request the assistance of qualified maintenance personnel to verify that the point of leakage has been repaired or rectified before you restore the operations of the unit.

### 6.4.3 Shorter maintenance and replacement cycle

In the following situations, the "maintenance cycle" and "replacement cycle" may be shortened.

If the unit is used in the following situations:

- Temperature and humidity fluctuations are outside the normal ranges.
- Large power fluctuations (voltage, frequency, waveform distortion etc.) (must not use the unit if the power fluctuations exceed the allowed range).
- Frequent collisions and vibrations.
- The air may contain dust, salt, harmful gas, or oil such as sulphite and hydrogen sulphide.
- The unit is frequently turned on and off of unit or the operating time is too long (in places where the air conditioning is on for 24 hours a day).

The system maintenance must be carried out by qualified maintenance personnel:

Table 7.1

Symptom	Measures
The safety device, such as a fuse, circuit breaker or a leakage circuit breaker is triggered frequently or the ON/OFF switch is not working properly.	Turn off the main power switch.
The operating switch is not functioning normally.	Turn off the power supply.
The unit number is displayed on the user interface, and the operating indicator is flickering, and an error code is shown on the screen as well.	Notify the installation personnel and report the error code.

Other than the above-mentioned situations, and where the fault is not obvious, if the system continues to malfunction, carry out the following steps to investigate.

Table 7.2

Symptom	Measures
The system does not run at all.	<p>Check if there is a power failure. Wait for the power supply to be restored. If a power failure occurs when the unit is still running, the system will restart automatically once the power is restored.</p> <p>Check if the fuse is broken or if the circuit breaker is working. If necessary, replace the fuse or reset the circuit breaker.</p>
The system works fine in the fan-only operating mode but stops running once it enters the heating or cooling mode.	<p>Check if the air inlets or outlets of the outdoor or indoor units are blocked by any obstacles. Remove the obstacles, and maintain good ventilation in the room.</p>
The system is running but there is poor cooling or heating effect.	<p>Check if the air inlets or outlets of the outdoor or indoor units are blocked by any obstacles.</p> <p>Remove the obstacles, and maintain good ventilation in the room.</p> <p>Check if the filter is blocked (please refer to the "Maintenance" section in the manual of the indoor unit).</p> <p>Check the temperature settings.</p> <p>Check the fan speed settings on the user interface.</p> <p>Check if the doors and windows are open. Close the doors and windows to shut out the wind from the external environment.</p> <p>Check if there are too many people in the room when the cooling mode is in operation. Check if the heat source of the room is too high.</p> <p>Check if there is direct sunlight shining into the room. Use curtains or blinds.</p> <p>Check that the angle of air flow is appropriate.</p>

## 7 TROUBLESHOOTING

The warranty does not cover the damage caused by dismantling or cleaning of the internal components by unauthorized agents.

### WARNING

- When any unusual situations arise (burning smell, etc.), stop the unit immediately and turn off the power.
- As a result of a certain situation, the unit has caused damage, an electric shock, or a fire. Please contact the agent.



## 7.1 Error Code: Overview

If an error code appears on the controller, please contact the installation personnel and inform them of the error code, device model, and serial number (you can find the information on the nameplate of the unit).

Table 7.3 Error code

Error code	Error description	Manual restart required
A01	Emergency stop	NO
xA61	Address (x) of the slave unit error	NO
AAx	No.x driver mismatch	NO
xb53	No. x cooling fan error	YES
C13	Outdoor unit address is repeated	NO
C21	Communication error between indoor and master unit	NO
C26	Number of indoor units detected by master unit has decreased or less than the setting amount	NO
C28	Number of indoor units detected by master unit has increased or more than the setting amount	NO
xC31	Communication error of address X slave outdoor unit	NO
C32	Number of slave units detected by master unit has decreased	NO
C33	Number of slave units detected by master unit has increased	NO
xC41	Communication error between main control chip and inverter driver chip	NO
E41	Outdoor ambient temperature sensor (T4) error (open/short)	NO
F31	Plate heat exchanger cooling refrigerant inlet temperature sensor (T6B) error (open/short)	NO
F41	Outdoor heat exchanger temperature sensor (T3) error (open/short)	NO
F51	Plate heat exchanger cooling refrigerant inlet temperature sensor (T6A) error (open/short)	NO
F62	Inverter module temperature (NTC) protection	NO
F63	Non-inductance Resistor temperature (Tr) protection	NO
F6A	F62 protection occurs 3 times in 100 minutes	YES
xF71	No.(x) compressor discharge temperature sensor (T7C) error (open/short)	YES
xF72	No.(x) compressor discharge temperature (T7C) protection	NO
F75	Compressor discharge insufficient superheat protection	NO
F7A	F72 protection occurs 3 times in 100 minutes	YES
F81	Gas stop-valve temperature sensor (Tg) error (open/short)	NO
F91	Liquid pipe temperature sensor (T5) error (open/short)	NO
FA1	Outdoor heat exchanger inlet temperature sensor (T8) error (open/short)	NO
FC1	Outdoor heat exchanger outlet temperature sensor (TL) error (open/short)	NO
Fd1	Compressor suction temperature sensor (T7) error (open/short)	NO
xL--	No. (x) compressor error. Refer to Table 7.5 for indications of "--"	YES
xL01	xL1* or xL2* error occurs 3 times in 60 minutes. Refer to Table 7.5 for indications of "**"	YES
xJ--	No. (x) fan motor error. Refer to Table 7.6 for indications of "--"	YES
xJ01	xJ1* or xJ2* error occurs 10 times in 60 minutes. Refer to Table 7.6 for indications of "**"	YES
P11	High pressure sensor error	NO
P12	Discharge pipe high pressure protection	NO
P13	Discharge pipe high pressure switch protection	NO
P14	P12 error occurs 3 times in 60 minutes	YES
P21	Low pressure sensor error	YES
P22	Suction pipe low pressure protection	NO
P24	Suction pipe low pressure abnormal rise	NO
P25	P22 error occurs 3 times in 100 minutes	YES

xP32	No. (x) compressor high DC bus current protection	NO
xP33	xP32 protection occurs 3 times in 100 minutes	YES
P51	High AC voltage protection	NO
P52	Low AC voltage protection	NO
P53	Power supply BN connect protection, or the phase is missing, or unbalanced when powered on	YES
P54	DC bus low voltage protection	NO
P55	DC bus ripple wave protection, or the phase is missing, or unbalanced when powered on	YES
xP56	No. (x) Inverter module DC bus low voltage error	YES
xP57	No. (x) Inverter module DC bus high voltage error	YES
xP58	No. (x) Inverter module DC bus excessively high voltage error	YES
P71	EEPROM error	YES
Pb1	EasyCom overcurrent error	YES
Pd1	Anti-condensation protection	NO
Pd2	Pd1 protection occurs 2 times in 60 minutes	YES
1b01	Electronic expansion valve (EEVA) error	YES
2b01	Electronic expansion valve (EEVB) error	YES
3b01	Electronic expansion valve (EEVC) error	YES
4b01	Electronic expansion valve (EEVD) error	YES
bA1	EasyCom cannot control indoor unit's electronic expansion valve	YES

Note: 'x' is a placeholder for the fan or compressor address, with 1 representing fan A or compressor A and 2 representing fan B or compressor B.

Table 7.4 Installation and debugging error code

Error code	Error description	Manual re-start required
U11	Outdoor unit type setting error	YES
U12	Capacity setting error	YES
U21	The system contains the 1 <sup>st</sup> generation indoor unit or the indoor units address are repeated	YES
U31	No test run or unsuccessful test run, please re-enter the test run.	YES
U32	Outdoor temperature out of operating range	YES
U33	Indoor temperature out of operating range	YES
U34	Outdoor and indoor temperature out of operating range	YES
U35	Liquid side stop valve is not opened	YES
U37	Gas side stop valve is not opened	YES
U38	No address	YES
U3A	The communication cable is connected incorrectly	NO
U3b	The installation environment is abnormal	YES
U3C	Auto mode error	NO
U41	Common indoor unit exceeds the allowable connection range	YES
U42	Fresh Air Processing indoor unit exceeds the allowable connection range	YES
U43	AHU kit (discharge air temperature control) is out of the allowable connection range	YES
U44	AHU kit (return air temperature control) is out of the allowable connection range	YES
U48	The total capacity of the indoor unit is out of the allowable connection range	YES
U51	Detected more than one outdoor unit in the individual VRF system	YES
U53	Detected different series outdoor units in the same VRF system	YES

Table 7.5 Compressor driver error code

Error code	Error description	Manual re-start required
xL1E	Hardware overcurrent	NO
xL11	Software overcurrent	NO
xL12	Software overcurrent protection lasting 30s	NO
xL2E	Inverter module high temperature protection	NO
xL3E	Low bus voltage error	NO
xL31	High bus voltage error	NO
xL32	Serious over voltage error of bus	NO
xL33	Bus voltage drop fault	NO
xL43	Abnormal current sampling	NO
xL5E	Startup failed	NO
xL51	Out-of-step error	NO
xL6E	Motor phase loss protection	NO

Note: 'x' is a placeholder for the compressor address, with 1 representing compressor A and 2 representing compressor B.

Table 7.6 Fan motor error code

Error code	Error description	Manual re-start required
xJ1E	Hardware overcurrent	NO
xJ11	Software overcurrent	NO
xJ12	Software overcurrent protection lasting 30s	NO
xJ2E	Inverter module high temperature protection	NO
xJ3E	Low bus voltage error	NO
xJ31	High bus voltage error	NO
xJ32	Serious over voltage error of bus	NO
xJ43	Abnormal current sampling	NO
xJ5E	Startup failed	NO
xJ51	Out-of-step error	NO
xJ6E	Motor phase loss protection	NO

Note: 'x' is a placeholder for the fan address, with 1 representing fan A and 2 representing fan B.

Table 7.7 Status code

Status code	Code description	Manual re-start required
d0x	Oil return running, x represents oil return operation steps	NO
dfx	Defrost running, x represents defrosting operation steps	NO
d11	Outdoor ambient temperature exceeds the upper limit in Heating mode	NO
d12	Outdoor ambient temperature exceeds the lower limit in Heating mode	NO
d13	Outdoor ambient temperature exceeds the upper limit in Cooling mode	NO
d14	Outdoor ambient temperature exceeds the lower limit in Cooling mode	NO
d31	Refrigerant judgment, no result	NO
d32	Refrigerant quantity judgment, significantly excessive	NO
d33	Refrigerant quantity judgment, slightly excessive	NO
d34	Refrigerant quantity judgment, normal	NO
d35	Refrigerant quantity judgment, slightly insufficient	NO
d36	Refrigerant quantity judgment, significantly insufficient	NO
d41	There is no power indoor unit in the system, EasyCom is controlling the indoor unit's valve	NO
d42	Communication error between the outdoor unit and the expansion board	NO

## 7.2 Fault Symptom: Non Air Conditioning Issues

The following fault symptoms are not caused by the air conditioning:

### 7.2.1 Fault symptom: System cannot run

The air conditioner does not start immediately after pressing the switch button on the controller. If the operating indicator lights up, the system is working normally. To prevent overloading of the compressor motor, restart the air conditioner 12 minutes after the switch button is pressed to prevent it from shutting down immediately after it turns on. The same start-up delay occurs after the mode selector is pressed.

### 7.2.2 Fault symptom: Fan speed is not consistent with the setting

Even if the fan speed regulation button is pressed, the fan speed does not change. During heating, when the indoor temperature reaches the set temperature, the outdoor unit will shut down, and the indoor unit switches to the quiet fan speed mode. This is to prevent cold air from blowing directly at the room user. The fan speed will not change even when another indoor unit is heating, if the button is pressed.

### 7.2.3 Fault symptom: Fan direction is not consistent with the settings

The air direction is not consistent with the user interface display. The air direction does not swing. This is because the unit is controlled by the centralized controller.

### 7.2.4 Fault symptom: A unit is emitting white smoke (indoor unit)

When cooling during high humidity, if the interior pollution of the indoor unit is severe, the indoor temperature distribution will be uneven. The interior of the indoor unit should be cleaned. Ask the agent for detailed information on how to clean the unit. This operation must be carried out by qualified maintenance personnel.

Surface immediately after cooling has stopped and when the indoor humidity is relatively low. This is due to the steam produced by the warm refrigerant gas on its return path to the indoor unit.

### 7.2.5 Fault symptom: A unit is emitting white smoke (indoor unit, outdoor unit)

After defrosting, switch the system to the heating mode. The moisture produced by the defrosting operation will become steam which is discharged out of the system.

### 7.2.6 Fault symptom: The air conditioner is producing noise (indoor unit)

A "zeen" sound is heard the moment the system is powered on. This noise is produced by the electronic expansion valves inside the indoor unit as they begin to work. The sound volume will be reduced in about 1 minute.

A soft and continuous "shah" sound can be heard when the system is in cooling mode or has stopped running. This noise can be heard when the drainage pump is running (optional accessory).

A loud creaking "pishi-pishi" sound can be heard once the system stops after it has heated up the room. The expansion and contraction of plastic parts caused by temperature changes will also make this noise.

Once the indoor unit stops, a soft "sah" or "choro-choro" sound can be heard. This noise can be heard when another indoor unit is still running. A small amount of refrigerant flow must be maintained to prevent oil and refrigerant residues in the system.

### 7.2.7 Fault symptom: Noise from air conditioner (indoor unit, outdoor unit)

A soft, continuous hissing sound can be heard when the system is in cooling or defrosting operation. This is the sound of the refrigerant gas flowing in the indoor and outdoor units.

A hissing sound is heard the moment the system starts or stops operation or after the defrosting operation has been completed. This is the noise produced when the refrigerant flow is stopped or changed.

### 7.2.8 Fault symptom: Noise from air conditioner (outdoor unit)

When the tone of the operating noise changes. This noise is caused by frequency changes.

### 7.2.9 Fault symptom: Dust and dirt in the unit

When using the unit for the first time, this is because there is dust inside the unit.

### 7.2.10 Fault symptom: The unit is emitting a strange odor

This unit will absorb the odors of rooms, furniture, cigarettes and others, and then disperse the odors again.

Sometimes small animals stray into the unit, which can also cause odors.

### 7.2.11 Fault symptom: ODU fan does not run

In the course of operation. Control the speed of the fan motor to optimize the product operations.

### 7.2.12 Fault symptom: Hot air is felt when the indoor unit stops

Different types of indoor units are operating in the same system. When another unit is running, part of the refrigerant will still flow through this unit.

## 8 CHANGING INSTALLATION SITE

Please contact the agent to dismantle and reinstall the units. You need specialized skills and technology to move the units.

## 9 DISPOSAL

The unit uses hydrogen fluorocarbons. Please contact the agent when you want to dispose the unit. Based on the requirements of the law, the collection, transportation and disposal of refrigerants must be in accordance with the regulations governing the collection and destruction of hydrofluorocarbons.

# INSTALLATION MANUAL

## 1 OVERVIEW

### 1.1 Notice to Installation Personnel

#### 1.1.1 Overview

If you are uncertain about how to install or run the unit, please contact the agent.

#### WARNING

- Make sure the installation, testing and materials used comply with applicable laws.
- Plastic bags should be disposed of properly. Keep away from children. Potential risk: Asphyxia.
- Do not touch the refrigerant piping, water piping or internal parts while the unit is operating or immediately after it has finished operating. The unit could be very hot or cold. Let it return to a normal temperature first. If you need to touch the unit, wear protective gloves.
- Do not touch leaked refrigerant.

#### CAUTION

- Please wear the appropriate personal protective tools during installation, maintenance or repair of the system (protective gloves, safety glasses, etc.).
- Do not touch the air inlet or aluminum fin of the unit.

#### NOTE

- The figure shown in this manual is for reference only and may be slightly different from the actual product.
- Improper installation or connection of equipment and accessories may cause electrical shock, short circuits, leaks, fires, or other damage to the equipment. Use only accessories, equipment and spare parts made or approved by the manufacturer.
- Take appropriate measures to prevent small animals from entering the unit. Contact between small animals and electrical components may cause the system to malfunction, leading to smoke or fire.
- Do not place any object or equipment on top of the unit.
- Do not sit, climb, or stand on the unit.
- The operation of this equipment in a residential environment could cause radio interference.

#### 1.1.2 Installation site

- Provide sufficient space around the unit for maintenance and air circulation.
- Make sure the installation site can bear the weight and vibrations of the unit.
- Make sure the area is well ventilated.
- Make sure the unit is stable and level.

Do not install the unit in the following locations:

- An environment in which there is a potential risk of explosions.
- Where there is equipment emitting electromagnetic waves. Electromagnetic waves may disrupt the control system, and cause the unit to malfunction.
- Where there are existing fire hazards such as leakage of flammable gases, carbon fibers, and combustible dust (such as diluents or gasoline).
- Where corrosive gases (such as sulfurous gases) are produced. Corrosion of copper pipes or welded parts may lead to refrigerant leakage.

#### 1.1.3 Refrigerant

#### WARNING

- During the test, do not exert a force greater than the maximum allowed pressure on the product (as shown on the nameplate).

## WARNING

- Take appropriate precautions to prevent refrigerant leakage. If the refrigerant gas leaks, ventilate the area immediately. Possible risks: An excessively high concentration of refrigerant in an enclosed area can lead to anoxia (oxygen deficiency). The refrigerant gas may produce a toxic gas if it comes in contact with fire.
- Refrigerant must be recovered. Do not release it into the environment. Use the vacuum pump to draw the refrigerant out from the unit.

## NOTE

- Make sure the refrigerant piping is installed in accordance with the applicable law. In Europe, EN378 is the applicable standard.
  - Make sure the piping and connections are not placed under pressure.
  - After all the piping has been connected, check to make sure there are no gas leaks. Use nitrogen to conduct the leak check for gas.
  - Do not charge refrigerant before the wiring layout is completed.
  - Only charge the refrigerant after the leak tests and vacuum drying have been completed.
  - When charging the system with refrigerant, do not exceed the allowable charge to prevent liquid slugging.
- 
- Do not charge more than the specified amount of refrigerant. This is to prevent the compressor from malfunctioning.
  - The refrigerant type is clearly marked on the nameplate.
  - The unit is charged with refrigerant when it is shipped from the factory. But depending on the piping dimensions and length, the system may require additional refrigerant.
  - Only use tools specific to the type of system refrigerant to make sure the system can withstand the pressure, and prevent foreign objects from entering the system.
  - Follow the steps below to charge the liquid refrigerant:  
Open the refrigerating cylinder slowly.  
Charge the liquid refrigerant. Charging with gas refrigerant may hamper normal operations.

## CAUTION

Once refrigerant charging is completed or suspended, close the refrigerant tank valve immediately. The refrigerant may volatilize if the refrigerant tank valve is not closed in time.

## 1.1.4 Electricity

### WARNING

- Make sure you switch off the power of the unit before you open the electric control box, and access any circuit wiring or components inside. At the same time, this prevents the unit from being accidentally powered up during installation or maintenance work.
- Once you open the cover of the electric control box, do not let any liquid spill into the box, and do not touch the components in the box with wet hands.
- Cut off the power supply more than 10 minutes prior to access the electrical parts. Measure the voltage of the main circuit capacitor or electrical component terminals to make sure the voltage is less than 36 V before you touch any circuit components. Refer to the connections and wiring on the nameplate for the master circuit terminals and connections.
- The installation must be completed by professionals, and must comply with local laws and regulations.
- Make sure the unit is properly grounded, in compliance with local laws.
- Use only copper core wires for installation.
- Wiring must be carried out in accordance with what is stated on the nameplate.
- The unit does not include a safety switch device. Make sure a safety switch device that can completely disconnect all polarities is included in the installation, and that the safety device can be completely disconnected when there is excessive voltage (such as during a lightning strike).
- Make sure the wiring ends are not subjected to any external force. Do not pull or squeeze the cables and wires. At the same time, make sure the wiring ends are not in contact with the piping or sharp edges of the sheet metal.
- Do not connect the grounding wire to public pipes, telephone earth wires, surge absorbers and other places that are not designed for grounding. Improper grounding could lead to electrical shock.
- Use a dedicated power supply cord for the unit. Do not share the same power source with other equipment.
- A fuse or circuit breaker must be installed, and these must conform to local laws.
- Make sure an electric leakage protection device is installed to prevent electrical shock or fire. The model specifications and characteristics (anti high-frequency noise characteristics) of the electric leakage protection device are compatible with the unit to prevent frequent tripping.
- Make sure a lightning rod is installed if the unit is placed on the roof or other places that can be easily struck by lightning.

## **⚠ WARNING**

- Make sure all terminals of the components are firmly connected before you close the cover of the electric control box. Before you power on and start the unit, check that the cover of the electric control box is tight and secured properly with screws. Do not let any liquid spill into the electric control box, and do not touch the components in the box with wet hands.
- The appliance shall be installed in accordance with national wiring regulations.
- If the supply cord is damaged, it must be replaced by the manufacturer or its service agent or a similarly qualified person in order to avoid hazards.
- An all-pole disconnection switch with a contact separation of at least 3mm in all poles should be connected in fixed wiring.
- The dimensions of the space necessary for correct installation of the appliance including the minimum permissible distances to adjacent structures.
- The temperature of the refrigerant circuit will be high. Please keep the interconnection cable away from the copper tube.

## **💡 NOTE**

- Do not install the power cord near equipment that is susceptible to electromagnetic interference, such as TV, and radios to prevent interference.
- Use a dedicated power supply cord for the unit. Do not share the same power source with other equipment. A fuse or circuit breaker must be installed, and these must conform to local laws.

## **i INFORMATION**

The installation manual is only a general guide on the wiring and connections, and is not specifically designed to contain all information regarding this unit.

## **1.2 Notice to Users**

- If you are unsure how to run the unit, please contact the installation personnel.
- This unit should not be operated by people who lack sufficient physical strength, cognitive sense or mental ability, or who lack experience and knowledge (including children). For their own safety, they should not use this unit unless they are supervised or guided by someone who is in charge of their safety. Children must be monitored to ensure that they do not play with this product.

## **⚠ WARNING**

To prevent electrical shock or fire:

- Do not wash the electric box of the unit.
- Do not operate the unit with wet hands.
- Do not place any items that contain water on the unit.

## **💡 NOTE**

- Do not place any object or equipment on top of the unit.
- Do not sit, climb, or stand on the unit.

## **2 PACKING BOX**

### **2.1 Overview**

This chapter mainly introduces the subsequent operations after the outdoor unit has been delivered to the installation site and unpacked.

This specifically includes the following information:

- Unboxing and handling the outdoor unit.
- Taking out the accessories of the outdoor unit.
- Dismantling the transport rack.

Remember the following:

- At the time of delivery, check the unit for any damage. Report any damage immediately to the carrier's claim agent.
- Transport the packaged unit as close as possible to its final installation site to prevent damage during the handling process.
- Take note of the following items when transporting the unit:



Fragile. Handle with care.



Keep the unit with its front facing upwards so as not to damage the compressor.

- Select the unit transportation path in advance.
- As shown in the following figure, it is better to use a crane and two long belts to lift the unit. Handle the unit carefully to protect it, and note the position of the center of gravity of the unit.

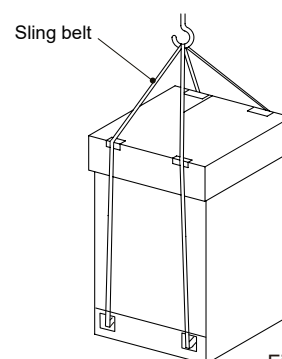
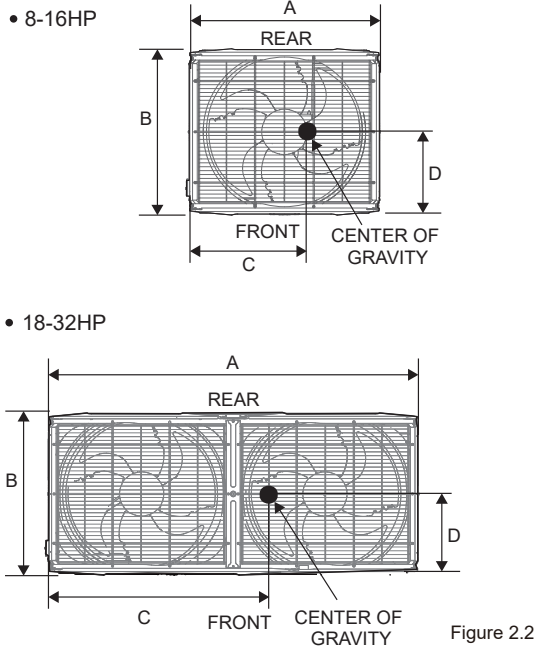

Figure 2.1

Center of gravity position is shown in Figure 2.2:

Table 2.1 Unit: mm

Model	A	B	C	D
8-16HP	940	825	449	487
18-24HP	1340	825	609	424
26-32HP	1880	825	842	476



**NOTE**

- Use a leather belt that can adequately support the weight of the unit, and has a width  $\leq 20$  mm.
- Images are for reference only. Please refer to the actual product.
- Do not remove any packaging while hoisting the unit. Where the unit is not packed or the package is damaged, use a gasket or package to protect the unit.
- The belt must have enough strength to bear the weight of the unit; keep the machine balanced and ensure the unit is lifted safely and stably.

Forklift method

- To move the unit with a forklift, insert the forks into the opening at the bottom of the unit, as shown in Figure 2.3.
- For anti-corrosion models, put a pad on the forks to prevent damage to the bottom frame paint of the unit.

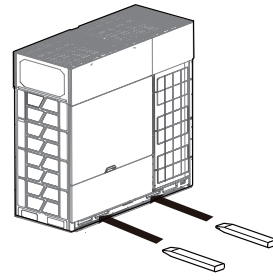

Figure 2.3

## 2.2 Unboxing the Outdoor Unit

Take the unit out of the packing materials:

- Be careful not to damage the unit when you use a cutting tool to remove the wrapping film.
- Remove the four nuts on the wooden back stand.

**WARNING**

Plastic film should be disposed of properly. Keep away from children. Potential risk: Asphyxia.

## 2.3 Taking Out Accessories of the Outdoor Unit

- The accessories for the unit are stored in two parts. Documents like the manual are located at the top of the unit. Accessories like the pipes are located inside the unit. The unit contains the following accessories:

Table 2.2 Accessories

Name	Qty.	Appearance	Function
Owner's and installation manual	1		—
Erp information	1		—
L-shaped pipe connection	2		To connect gas and liquid pipes
Build-out resistor	1		To improve communication stability
Wrench	1		To remove the side plate screws
Bluetooth Module	1		Refer to attached manual
Magnetic ring	1		Improve the EMI effect of communication
CN93 Auxiliary connector	1		Output dry contact



L-shaped pipe size

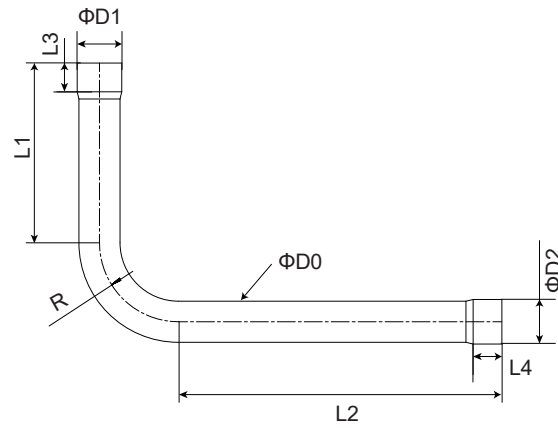

Figure 2.4

Table 2.3

Unit: mm

HP	PIPE	$\Phi D0(OD)$	$L1$	$L2$	$L3$	$L4$	$\Phi D1(ID)$	$\Phi D2(ID)$	$R$
8-12HP	Gas pipe	25.4	130	230	20	20	25.4	25.4	50
	Liquid pipe	12.7	160	265	15	15	12.7	12.7	25
14-16HP	Gas pipe	28.6	125	225	20	20	28.6	28.6	55
	Liquid pipe	15.9	155	255	15	15	15.9	15.9	30
18-24HP	Gas pipe	31.8	130	220	25	20	28.6	31.8	60
	Liquid pipe	19.1	162	245	15	15	15.9	19.1	40
26HP	Gas pipe	31.8	130	130	25	25	31.8	31.8	60
	Liquid pipe	22.2	165	165	20	20	22.2	22.2	40
28-32HP	Gas pipe	38.1	155	115	20	20	34.9	38.1	80
	Liquid pipe	22.2	165	165	20	20	22.2	22.2	40

## 2.4 Pipe Fittings

- The schematic after the L-shaped pipe (from accessories) is properly connected to the unit is shown below:

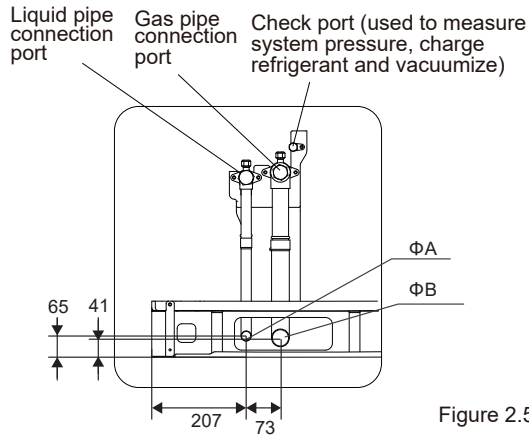

Figure 2.5

Table 2.4

		Unit: mm				
HP	SIZE	8-12	14-16	18-24	26	28-32
ΦA(ID)		Φ12.7	Φ15.9	Φ19.1	Φ22.2	Φ22.2
ΦB(ID)		Φ25.4	Φ28.6	Φ31.8	Φ31.8	Φ38.1

## 3 OUTDOOR UNIT COMBINATION

### 3.1 Overview

This chapter contains the following information:

- List of branch joint fittings.
- Recommended combination for outdoor units.

## 3.2 Branch Joints

Table 3.1 For V8 combinable series

Description	Model
Outdoor Unit Branch Joint Assembly	FQZHW-02N1E
	FQZHW-02N1G
	FQZHW-03N1E
	FQZHW-03N1G
Indoor Unit Branch Joint Assembly	FQZHN-01D
	FQZHN-02D
	FQZHN-03D
	FQZHN-04D
	FQZHN-05D
	FQZHN-06D
	FQZHN-07D

On the choice of branch joints, refer to section "4.3.3 Selecting piping diameters".

## 3.3 Recommended Outdoor Unit Combination

### ⚠ CAUTION

- The total capacity of the IDU shall be between 50%–130% of the combined capacity of the ODU.
- In the system where all indoor units are running at the same time, the total capacity of the indoor units should be less than or equal to the combined capacity of the outdoor unit to prevent overloading in poor operating conditions or narrow operating space.
- The total capacity of the indoor units can be up to a maximum of 130% of the combined capacity of the outdoor unit for a system where not all the indoor units are operating at the same time.
- If the system is being used in a cold region (ambient temperature is  $-10^{\circ}\text{C}$  or below) or a very hot, heavy-load environment, the total capacity of the indoor units should be less than the combined capacity of the outdoor unit.
- The heating capacity of the heat pump will reduce when the outdoor ambient temperature is lowered. Therefore, when installing a heat pump in an area with low temperatures, it is recommended to use the IDU with an auxiliary heater.

Table 3.2 Recommended outdoor unit combination

HP \ HP	8	10	12	14	16	18	20	22	24	26	28	30	32	Max Qty of indoor units
8	●													13
10		●												16
12			●											19
14				●										23
16					●									26
18						●								29
20							●							33
22								●						36
24									●					39
26										●				43
28											●			46
30												●		50
32													●	53
34				●			●							56
36					●		●							59
38				●					●					62
40					●				●					64
42						●			●					64
44								● ●						64
46								●	●					64
48									● ●					64
50						●							●	64
52							●						●	64
54								●					●	64
56									●				●	64
58										●			●	64
60											●		●	64
62												●	●	64
64													● ●	64
66				●			●						●	64

HP	8	10	12	14	16	18	20	22	24	26	28	30	32	Max Qty of indoor units
68					●		●						●	64
70				●					●				●	64
72					●				●				●	64
74						●			●				●	64
76								●●					●	64
78								●	●				●	64
80									●●				●	64
82						●							●●	64
84							●						●●	64
86								●					●●	64
88									●				●●	64
90										●			●●	64
92											●		●●	64
94												●	●●	64
96													●●●	64

## 4 PREPARATIONS BEFORE INSTALLATION

### 4.1 Overview

This chapter mainly describes the precautions and things to note before the unit is installed at the site.

This mainly includes the following information:

- Choosing and Preparing the Installation Site.
- Selecting and Preparing the Refrigerant Piping.
- Selecting and Preparing the Electrical Wiring.

### 4.2 Choosing and Preparing the Installation Site

#### 4.2.1 Site requirements for installation of the outdoor unit

- Provide sufficient space around the unit for maintenance and air circulation.
- Make sure the installation site can bear the weight and vibrations of the unit.
- Make sure the area is well ventilated.
- Make sure the unit is stable and level.
- Choose a place where the rain can be avoided as much as possible.
- The unit should be installed in a location where the noise generated by the unit will not create an inconvenience to people.
- Choose a site that will comply with the applicable laws.

Do not install the unit in the following locations:

- An environment where there is a potential risk of explosions.
- Where there is equipment emitting electromagnetic waves. Electromagnetic waves may disrupt the control system, and cause the unit to malfunction.
- Where there are existing fire hazards like leakage of flammable gases, carbon fibers, and combustible dust (such as diluents or gasoline).
- Where corrosive gases (such as sulphurous gases) are produced. Corrosion of copper pipes or welded parts may lead to refrigerant leakage.
- Where mineral oil mist, spray, or steam may exist in the atmosphere. Plastic parts may age, fall off or cause water leakage.
- Where there is a high salt content in the air such as places near the sea.

#### CAUTION

- Electric appliances that should not be used by the general public must be installed in a safe location to prevent others from getting close to these electric appliances.
- Both indoor and outdoor units are suitable for the installation of commercial and light industrial environment.
- An excessively high concentration of refrigerant in an enclosed area can lead to anoxia (oxygen deficiency).

#### NOTE

- This is a class A product. This product may cause radio interference in the home environment. The user may need to take the necessary measures if such a situation does arise.
- The unit described in this manual may cause electronic noise generated by radio frequency energy. The unit conforms to the design specifications and provides reasonable protection to prevent such interference. However, there is no guarantee that there will be no interference during a specific installation process.
- Therefore, it is suggested that you install the units and wires at an appropriate distance from devices like sound equipment and personal computers.

- Do take into considerations adverse environmental conditions such as strong winds, typhoons or earthquakes as improper installation may cause the unit to overturn.
- Take precautions to make sure water will not damage the installation space and environment in the event of a water leakage.
- If the unit is installed in a small room, refer to section 4.2.3 "Safety measures to prevent refrigerant leak" to make sure the refrigerant concentration does not exceed the permissible safety limit when there is a refrigerant leak.
- Make sure the air inlet of the unit is not facing the predominant wind direction. Incoming wind will disrupt the operations of the unit. If necessary, use a deflector as an air baffle.
- Add water discharge piping on the base so that the condensed water will not damage the unit, and prevent the pooling of water when work is in progress.

#### 4.2.2 Site requirements for installation of outdoor unit in cold regions

#### NOTE

- Snow protection equipment must be installed in areas with snowfall. Refer to the following figure, (malfunctions are more common when there are insufficient snow protection facilities). In order to protect the unit from accumulated snow, increase the height of the rack, and install a snow shield at the air inlets and outlets.
- Do not obstruct the air flow of the unit when you install the snow shield.

Make note of the following when installing the unit in areas affected by cold weather or snow:

- Avoid directly exposing the air outlet or air inlet to the wind.
- The local maximum snowfall should be taken into consideration when deciding the foundation height of ODU.
- The foundation or base height of the ODU is required to be the expected maximum snowfall thickness  $h_0 + 300\text{mm}$ , preventing the snow from contacting the bottom of the unit.

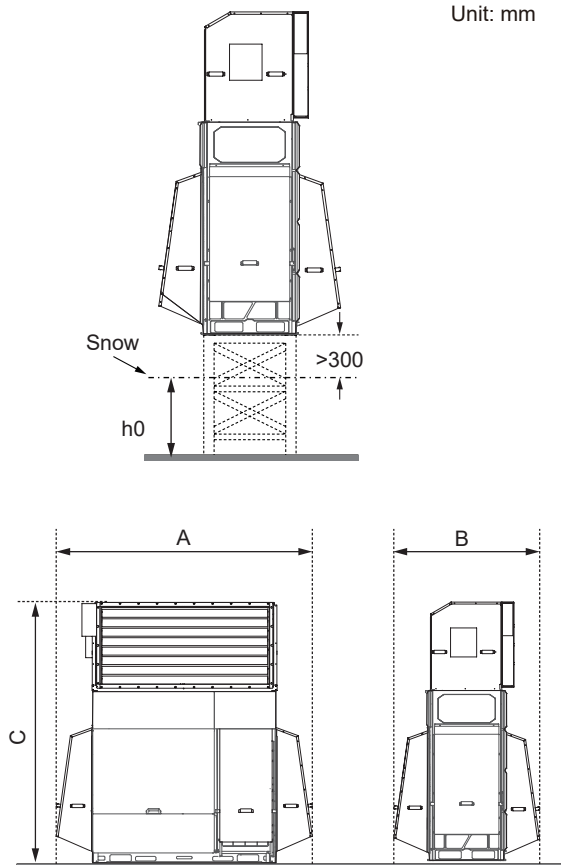

Unit: mm

Figure 4.1

Table 4.1

Unit: mm

HP	Size	A	B	C
8-16		1690	1200	2685
18-24		2090	1200	2685
26-32		1630	1575	2685

- When a snow shield needs to be installed, to ensure smooth air intake and supply of the ODU, conduct site planning and construction as follows:
- Installation of ODUs in a row (unit: mm)

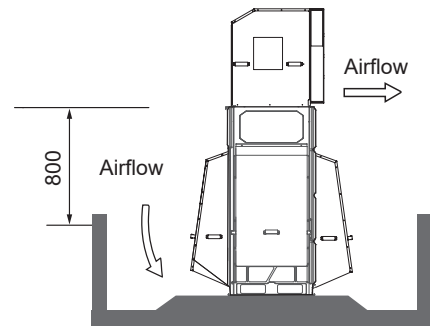
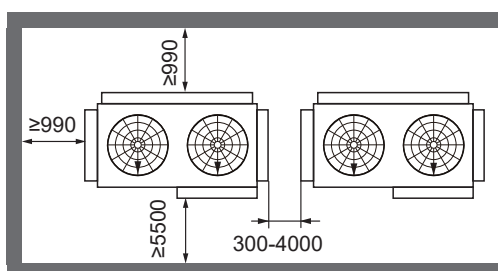

Figure 4.2

- Installation of ODUs in two rows (unit: mm)

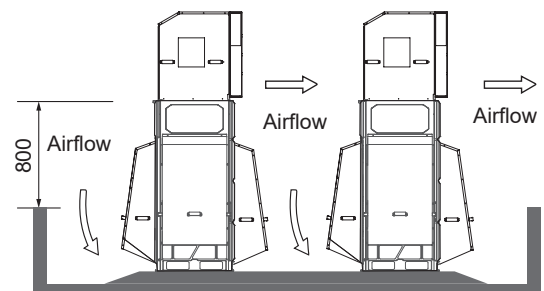
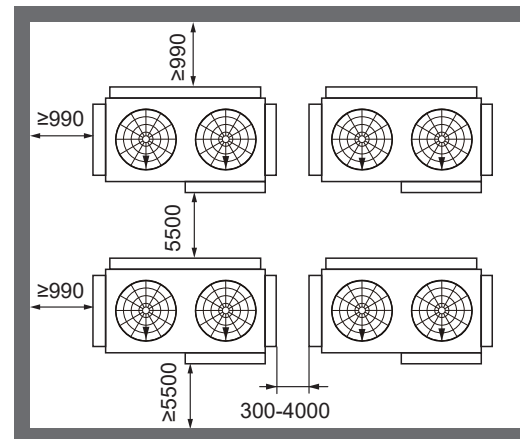
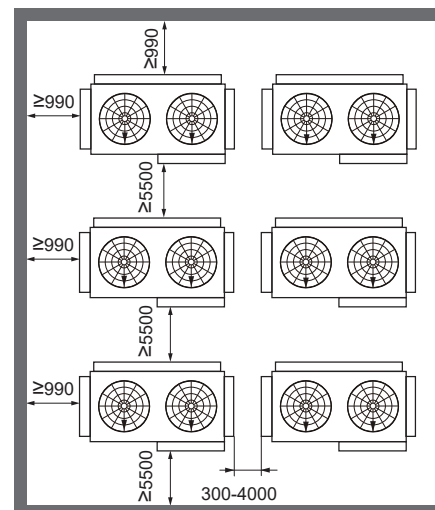

Figure 4.3

- Installation of ODUs in three rows (unit: mm)



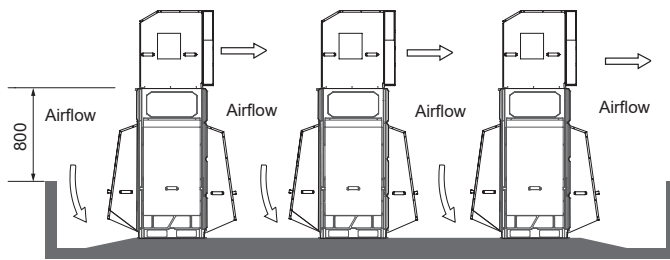

Figure 4.4

### 4.2.3 Safety measures to prevent refrigerant leaks

#### Safety measures to prevent refrigerant leak

The installation personnel must make sure the safety measures to prevent leaks comply with local regulations or standards. If the local regulations do not apply, the following criteria can be applied.

The system uses R410A as the refrigerant. R410A itself is a completely non-toxic, and non-combustible refrigerant. However, do ensure that the air conditioning unit is installed in a room with sufficient space. This is so that when there is a serious leak in the system, the maximum concentration of the refrigerant gas in the room will not exceed the stipulated concentration, and is consistent with the relevant local regulations and standards.

#### About the maximum concentration level

The calculation for the maximum concentration of the refrigerant is directly related to the occupied space that the refrigerant may leak to and the refrigerant's level of charge.

The measurement unit for concentration is kg/m<sup>3</sup> (weight of gaseous refrigerant that has a volume of 1 m<sup>3</sup> in the occupied space).

The highest permissible concentration must comply with the relevant local regulations and standards.

Based on the applicable European standards, the maximum permissible concentration level of R410A in the space occupied by humans is limited to 0.44 kg/m<sup>3</sup>. If this limit is exceeded, necessary measures shall be taken. Please confirm as follows:

- Calculate the total refrigerant charging amount.  
Total refrigerant charging amount = refrigerant charging amount of the unit itself + charging amount calculated according to the pipe length.
- Calculate the indoor volume (based on the minimum volume).
- Calculated refrigerant concentration = (total charging amount/indoor volume).

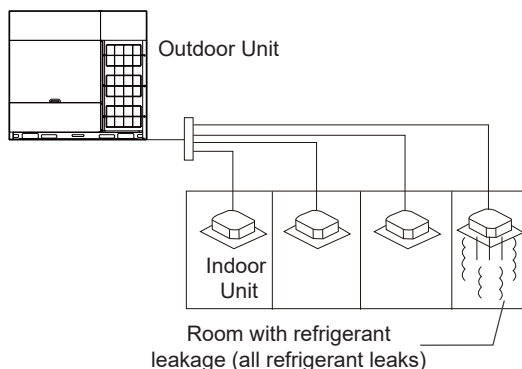

Figure 4.5

Countermeasures when exceeding the max concentration

- Please install a mechanical ventilation device.
- If it is impossible to change air frequently, please install a leak detection alarm device connected with the mechanical ventilation device.

## 4.3 Selecting and Preparing the Refrigerant Piping

### 4.3.1 Refrigerant piping requirements

#### NOTE

The R410A refrigerant pipeline system must be kept strictly clean, dry and sealed.

- Cleaning and drying: prevent foreign objects (including mineral oil or water) from mixing into the system.
- Seal: R410A does not contain fluorine, does not destroy the ozone layer, and does not deplete the ozone layer that protects the earth from harmful ultraviolet radiation. But if it is released, R410A can also cause a slight greenhouse effect. Therefore, you must pay special attention when you check the sealing quality of the installation.
- The piping and other pressure vessels must comply with the applicable laws and be suitable for use with the refrigerant. Use only phosphoric acid deoxidized seamless copper for the refrigerant piping.

- Foreign objects in the pipes (including lubricant used during pipe bending) must be  $\leq 30$  mg/10m.
- Calculate all piping lengths and distances.

### 4.3.2 Allowable length and height difference for refrigerant piping

Refer to the following table and figure (for reference only) to determine the appropriate size.

#### NOTE

- The equivalent length of each elbow and U-shape branch joint is 0.5m, and the equivalent length of each branch header is 1m.
- Install the indoor units such that they are as equidistant as possible on both sides of the U-shape branch joint.  
When the outdoor unit is above the indoor unit, and the level difference exceeds 20 m, it is recommended that an oil return bend be set up at every 10 m interval on the gas pipe of the main piping. The recommended specifications of the oil return bend are shown in Figure 4.8.
- The allowable length of the farthest indoor unit to the first branch joint in the system should be equal to or less than 40m unless specified conditions are met, in which case the permitted length is up to 120m. Please refer to requirement 2.
- Special-purpose branch joints from the manufacturer should be used for all branch joints. Failing to do so may lead to severe system malfunction.

Piping diagram of V8 combinable series

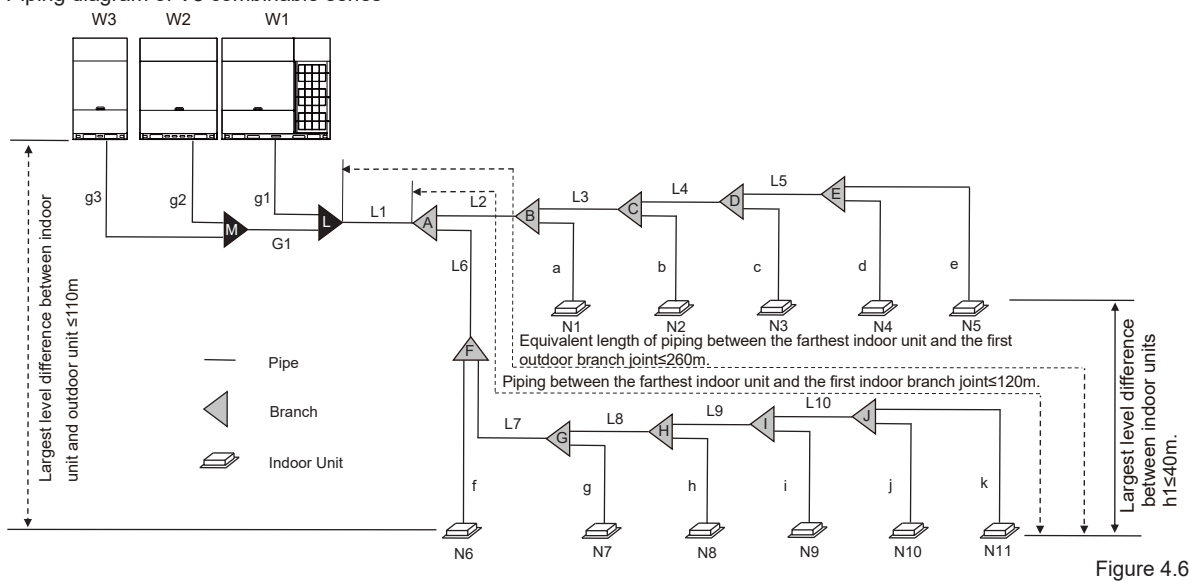

Figure 4.6

Table 4.2 Pipe and Component Names

Name	Designation	Name	Designation
Outdoor unit connection pipe	G1, g1, g2, g3	Indoor unit main pipe	L2 to L10
Outdoor unit branch joint	L, M	Indoor unit branch joint	A to J
Main pipe	L1	Indoor unit auxiliary connection pipe	a to k



Table 4.3 Summary of permitted refrigerant piping lengths and level differences

Category		Permitted values	Piping	
Piping lengths	Total piping length	≤1100m	$L1 + \sum(L2 \text{ to } 10) \times 2 + \sum(a \text{ to } k)$	
	Piping between the farthest indoor unit and the first outdoor branch joint	Actual length	≤220m	
		Equivalent length	≤260m	$L1 + L6 + L7 + L8 + L9 + L10 + k$ (Refer to Requirement 1)
	Piping between outdoor unit and outdoor branch joint	Actual length	≤10m	$g1 \leq 10m, g2 + G1 \leq 10m, g3 + G1 \leq 10m$
Piping between the farthest indoor unit and the first indoor branch joint		≤40(120)m	$L6 + L7 + L8 + L9 + L10 + k$ (Refer to Requirement 2)	
Level differences	Largest level difference between the indoor unit and outdoor unit	Outdoor unit is above	≤110m	(Refer to Requirement 3)
		Outdoor unit is below		
Largest level difference between indoor units		≤40m	(Refer to Requirement 4)	

The piping length and level difference requirements that apply are summarized in Table 4.3 and are fully described as follows.

- Requirement 1:** The piping between the farthest indoor unit (N11) and the first outdoor branch joint (L) should not exceed 220m (actual length) and 260m (equivalent length). (The equivalent length of each branch joint is 0.5m, and the equivalent length of each branch header is 1m.)
- Requirement 2:** The piping between the farthest indoor unit (N11) and the first indoor branch joint (A) should not exceed 40m in length ( $\sum\{L6 \text{ to } L10\} + k \leq 40m$ ) unless the following conditions are met and the following measures are taken, in which case the max permitted length is 120m.

**Conditions:**

- Each indoor auxiliary pipe (from each indoor unit to its nearest branch joint) joint does not exceed 40 m in length (a to k each ≤ 40m).
- The difference in length between {the piping from the first indoor branch joint (A) to the farthest indoor unit (N11)} and {the piping from the first indoor branch joint (A) to the nearest indoor unit (N1)} does not exceed 40m. That is:  $(L6 + L7 + L8 + L9 + L10 + k) - (L2 + a) \leq 40m$ .

**Measures:**

- Increase the diameter of the indoor main pipes (the piping between the first indoor branch joint and all other indoor branch joints, L2 to L10) as follows, except for indoor main pipes which are already the same size as the main pipe (L1), for which no diameter increases are required.

Table 4.4. Pipe size allowable increase diameters (mm)

Φ9.52 to Φ12.7	Φ12.7 to Φ15.9	Φ15.9 to Φ19.1
Φ19.1 to Φ22.2	Φ22.2 to Φ25.4	Φ25.4 to Φ28.6
Φ28.6 to Φ31.8	Φ31.8 to Φ38.1	Φ38.1 to Φ41.3
Φ41.3 to Φ44.5	Φ44.5 to Φ50.8	Φ50.8 to Φ54.0

- Requirement 3:** The largest level difference between indoor unit and outdoor unit should not exceed 110m (if the outdoor unit is above) or 110m (if the outdoor unit is below). Additionally: (i) If the outdoor unit is above and the level difference is greater than 20m, it is recommended that an oil return bend with dimensions as specified in Figure 4.8 be set every 10m in the gas pipe of the main pipe; and (ii) if the level difference is more than 40m (outdoor unit is below) or 50m (outdoor unit is above), the size of the main pipe (L1) should be increased as Table 4.7.

- Requirement 4:** The largest level difference between indoor units should not exceed 40m.

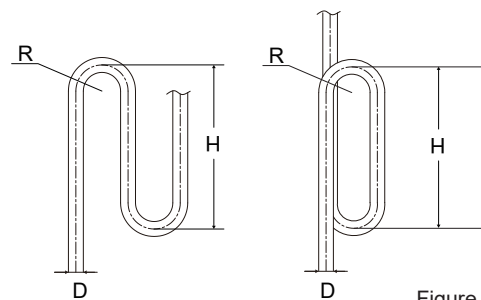

Figure 4.8

Unit: mm

Table 4.5

D	Φ19.1	Φ22.2	Φ25.4	Φ28.6	Φ31.8	Φ38.1	Φ41.3	Φ44.5	Φ50.8	Φ54.0	Φ63.5
R	≥31		≥45		≥60		≥80		≥90		
H	≥300						≥500				

### 4.3.3 Piping diameter

#### 1) Select the diameter of the main piping

- The main pipe (L1) and first indoor branch joint (A) should be sized according to Table 4.6 and Table 4.7.

Table 4.6

HP of ODU	Equivalent length of all liquid piping < 90 m		
	Gas side (mm)	Liquid side (mm)	The first indoor branch joint
8HP	Φ19.1	Φ9.52	FQZHN-01D
10HP	Φ22.2	Φ9.52	FQZHN-02D
12~14HP	Φ25.4	Φ12.7	FQZHN-02D
16HP	Φ28.6	Φ12.7	FQZHN-03D
18HP	Φ28.6	Φ15.9	FQZHN-03D
20~24HP	Φ28.6	Φ15.9	FQZHN-03D
26~34HP	Φ31.8	Φ19.1	FQZHN-03D
36~54HP	Φ38.1	Φ19.1	FQZHN-04D
56~66HP	Φ41.3	Φ19.1	FQZHN-05D
68~82HP	Φ44.5	Φ22.2	FQZHN-05D
84~88HP	Φ50.8	Φ25.4	FQZHN-06D
90~92HP	Φ50.8	Φ25.4	FQZHN-06D
94~96HP	Φ50.8	Φ25.4	FQZHN-06D

Table 4.7

HP of ODU	Equivalent length of all liquid piping ≥ 90 m		
	Gas side (mm)	Liquid side (mm)	The first indoor branch joint
8HP	Φ22.2	Φ12.7	FQZHN-02D
10HP	Φ25.4	Φ12.7	FQZHN-02D
12~14HP	Φ28.6	Φ15.9	FQZHN-03D
16HP	Φ31.8	Φ15.9	FQZHN-03D
18HP	Φ31.8	Φ15.9	FQZHN-03D
20~24HP	Φ31.8	Φ19.1	FQZHN-03D
26~34HP	Φ38.1	Φ22.2	FQZHN-04D
36~54HP	Φ41.3	Φ22.2	FQZHN-05D
56~66HP	Φ44.5	Φ22.2	FQZHN-05D
68~82HP	Φ50.8	Φ25.4	FQZHN-06D
84~88HP	Φ54.0	Φ25.4	FQZHN-06D
90~92HP	Φ54.0	Φ25.4	FQZHN-06D
94~96HP	Φ54.0	Φ28.6	FQZHN-07D

#### 2) Select the branch joint diameters for the indoor unit

Based on the total capacity of the indoor unit, select the branch joint for the indoor unit from the following table.

Table 4.8

Total capacity of indoor units A (×100W)	Gas side (mm)	Liquid side (mm)	Branch joint
A<168	Φ15.9	Φ9.52	FQZHN-01D
168≤A<224	Φ19.1	Φ9.52	FQZHN-01D
224≤A<330	Φ22.2	Φ9.52	FQZHN-02D
330≤A<470	Φ28.6	Φ12.7	FQZHN-03D
470≤A<710	Φ28.6	Φ15.9	FQZHN-03D
710≤A<1040	Φ31.8	Φ19.1	FQZHN-03D
1040≤A<1540	Φ38.1	Φ19.1	FQZHN-04D
1540≤A<1900	Φ41.3	Φ19.1	FQZHN-05D
1900≤A<2350	Φ44.5	Φ22.2	FQZHN-05D
2350≤A<2500	Φ50.8	Φ22.2	FQZHN-06D
2500≤A<3024	Φ50.8	Φ25.4	FQZHN-06D
3024≤A	Φ54.0	Φ28.6	FQZHN-07D

If the size of the branch joint pipe selected according to the above table is larger than that of the main pipe according to Table 4.6 or Table 4.7, the size of the branch joint pipe should be reduced to make it the same as the main pipe.

The pipe thickness of the refrigerant piping shall comply with the applicable legislation. The minimal pipe thickness for R410A piping must be in accordance with the table below.

Table 4.9

Piping outer diameter (mm)	Minimum thickness (mm)	Temper grade
Φ6.35	0.80	M-type
Φ9.52	0.80	
Φ12.7	1.00	
Φ15.9	1.00	
Φ19.1	1.00	
Φ22.2	1.00	Y2-type
Φ25.4	1.00	
Φ28.6	1.00	
Φ31.8	1.25	
Φ34.9	1.25	
Φ38.1	1.50	
Φ41.3	1.50	
Φ44.5	1.50	
Φ50.8	1.80	
Φ54.0	1.80	
Φ63.5	2.10	

Material: Only seamless phosphorus-deoxidized copper piping that complies with all applicable legislation should be used.

Thicknesses: Temper grades and minimum thicknesses for different diameters of piping should comply with local regulations.

Design pressure of R410 refrigerant is 4.2MPa (42bar).

If the required pipe size is not available, you can use other diameters by considering the following factors:

- If the standard size is not available in local market, a pipe that is one size larger should be used.
- In some circumstances, the pipe size needs to be one size larger than the standard size; this is the “Size up Size” (for example: when the equivalent length of all the liquid piping is larger than 90m, the pipe size needs to be one size up; when the piping length from the farthest indoor unit to the first indoor unit is more than 40m, the indoor main pipe size needs to be one size up to allow a piping length of up to 120m). If the “Size up Size” is not available in the local market, the standard size pipe must be used.
- Pipe sizes bigger than the corresponding “Size up Size” cannot be used under any circumstances.
- Calculation for the additional refrigerant must be adjusted according to section 5.9 on the determination of the additional refrigerant volume.

### 3) Select the branch joint diameters for the outdoor unit

Select the branch joint of the outdoor unit from the table below.

Table 4.10 For V8 combinable series

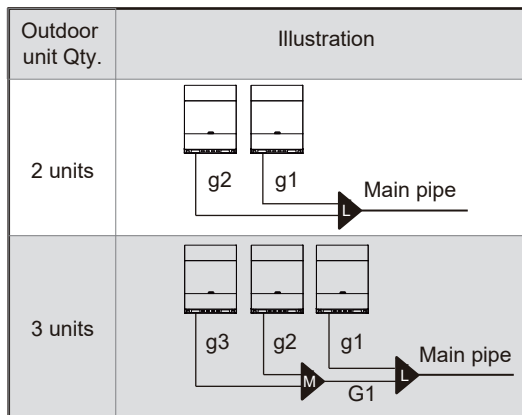

### NOTE

For systems with multiple units, the branch joints of the outdoor unit are sold separately.

Table 4.11 For V8 combinable series

Outdoor unit Qty.	Total parallel capacity of outdoor units	Outdoor connection pipes diameter	Branch joint kit
2 units	< 56HP	g1、g2: 8~12HP: Φ25.4/Φ12.7; 14~24HP: Φ31.8/Φ15.9; 26~32HP: Φ38.1/Φ19.1;	L: FQZHW-02 N1E
	≥56HP	g1、g2: 20~24HP: Φ31.8/Φ15.9; 26~32HP: Φ38.1/Φ19.1;	L: FQZHW-02 N1G
3 units	≤96HP	g1、g2、g3: 8~12HP: Φ25.4/Φ12.7; 14~24HP: Φ31.8/Φ15.9; 26~32HP: Φ38.1/Φ19.1; G1: Φ41.3/Φ22.2	L+M: FQZHW-0 3N1E

### 4) Indoor unit auxiliary connection pipe

Table 4.12

Indoor unit capacity A (×100W)	Gas side (mm)	Liquid side (mm)
A≤56	Φ12.7	Φ6.35
56<A≤160	Φ15.9	Φ9.52

### CAUTION

- If the indoor unit capacity exceeds the range in the table above, select the pipe diameter according to the manual of the indoor unit.
- The size of the indoor branch pipe shall not be larger than that of the main pipe. If the size of the main pipe selected according to the above table is larger than that of the main pipe, the size of the branch pipe shall be reduced to make it the same as that of the main pipe.

### 5) An example of refrigerant piping selection

The example below illustrates the piping selection procedure for a system consisting of two outdoor units (32HP+20HP) and 11 indoor units. The system's equivalent length of all liquid pipes is less than 90m; the piping between the farthest indoor unit and the first indoor branch joint is less than 40m in length, and each indoor auxiliary pipe (from each indoor unit to its nearest branch joint) is less than 10m in length.

- For V8 combinable series

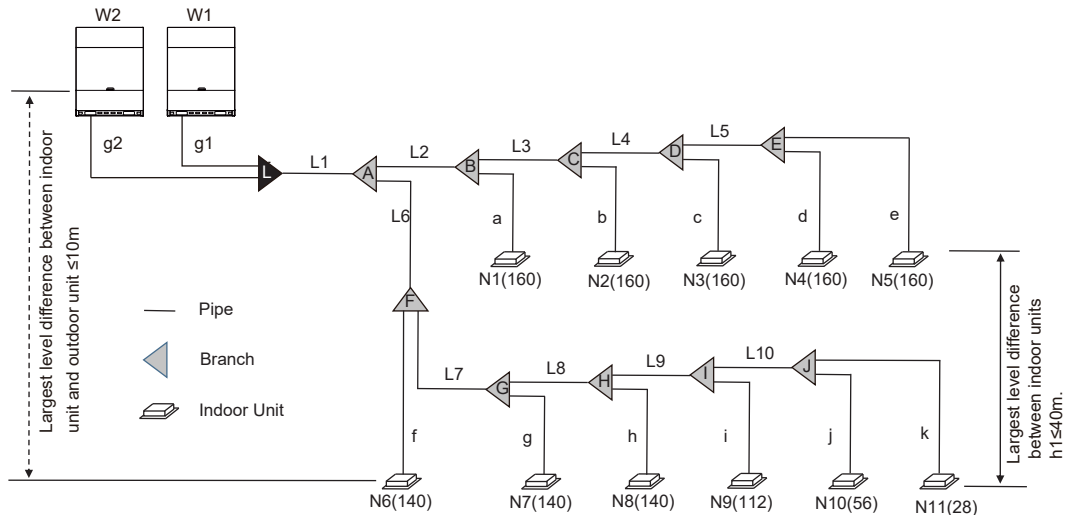

Figure 4.9

Select indoor main pipes and indoor branch B to J

- The indoor units (N4 and N5) downstream of indoor branch E have a total capacity of  $16 \times 2 = 32 \text{ kW}$ . Indoor main pipe L5 is  $\Phi 22.2 / \Phi 9.52$ . Indoor branch joint E is FQZHN-02D.
- The indoor units (N3 to N5) downstream of indoor branch D have a total capacity of  $16 \times 3 = 48 \text{ kW}$ . Indoor main pipe L4 is  $\Phi 28.6 / \Phi 15.9$ . Indoor branch joint D is FQZHN-03D.
- The indoor units (N2 to N5) downstream of indoor branch C have a total capacity of  $16 \times 4 = 64 \text{ kW}$ . Indoor main pipe L3 is  $\Phi 28.6 / \Phi 15.9$ . Indoor branch joint C is FQZHN-03D.
- The indoor units (N1 to N5) downstream of indoor branch B have a total capacity of  $16 \times 5 = 80 \text{ kW}$ . Indoor main pipe L2 is  $\Phi 31.8 / \Phi 19.1$ . Indoor branch joint B is FQZHN-03D.
- The indoor units (N10 and N11) downstream of indoor branch J have a total capacity of  $5.6 + 2.8 = 8.4 \text{ kW}$ . Indoor main pipe L10 is  $\Phi 15.9 / \Phi 9.52$ . Indoor branch joint J is FQZHN-01D.
- The indoor units (N9 to N11) downstream of indoor branch I have a total capacity of  $8.4 + 11.2 = 19.6 \text{ kW}$ . Indoor main pipe L9 is  $\Phi 19.1 / \Phi 9.52$ . Indoor branch joint I is FQZHN-01D.
- The indoor units (N8 to N11) downstream of indoor branch H have a total capacity of  $19.6 + 14 = 33.6 \text{ kW}$ . Indoor main pipe L8 is  $\Phi 28.6 / \Phi 12.7$ . Indoor branch joint H is FQZHN-03D.
- The indoor units (N7 to N11) downstream of indoor branch G have a total capacity of  $33.6 + 14 = 47.6 \text{ kW}$ . Indoor main pipe L7 is  $\Phi 28.6 / \Phi 15.9$ . Indoor branch joint G is FQZHN-03D.
- The indoor units (N6 to N11) downstream of indoor branch F have a total capacity of  $47.6 + 14 = 61.6 \text{ kW}$ . Indoor main pipe L6 is  $\Phi 28.6 / \Phi 15.9$ . Indoor branch joint F is FQZHN-03D.

Select the indoor auxiliary connection pipe a to k

- The capacity of indoor units N1 to N9 is larger than  $5.6 \text{ kW}$ , so the indoor auxiliary connection pipe a to i is  $\Phi 15.9 / \Phi 9.52$ .
- The capacity of indoor units N10 to N11 is equal or less than  $5.6 \text{ kW}$ , so the indoor auxiliary connection pipe j to k is  $\Phi 12.7 / \Phi 6.35$ .

Select main pipe (L1) and first indoor branch A

- The indoor units (N1 to N11) downstream of indoor branch joint A have a total capacity of  $80 + 61.6 = 141.6 \text{ kW}$ . The system's equivalent length of all liquid pipes is less than  $90 \text{ m}$ . The total capacity of the outdoor units is  $32 + 20 = 52 \text{ HP}$ . Main pipe L1 is  $\Phi 38.1 / \Phi 19.1$ . First Indoor branch A is FQZHN-04D.

Select outdoor connection pipes (g1 and g2) and outdoor branch (L)

- There are two outdoor units in the system. The master unit is  $32 \text{ HP}$ , the slave unit is  $20 \text{ HP}$ . Outdoor connection pipes g1 is  $\Phi 38.1 / \Phi 19.1$ , g2 is  $\Phi 31.8 / \Phi 15.9$ . Outdoor branch L is FQZHW-02N1E.

#### 4.3.4 Arrangement and layout of multiple outdoor units

- The piping between the outdoor units must be level and lower than the outdoor unit piping connection.

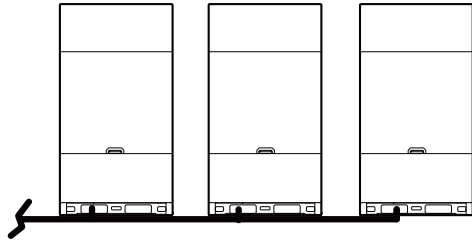

✓ Correct

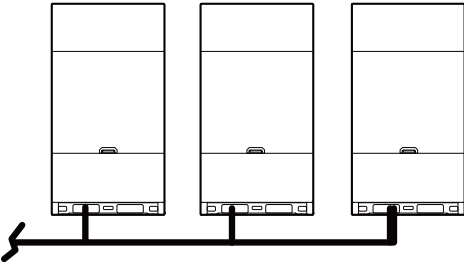

✓ Correct

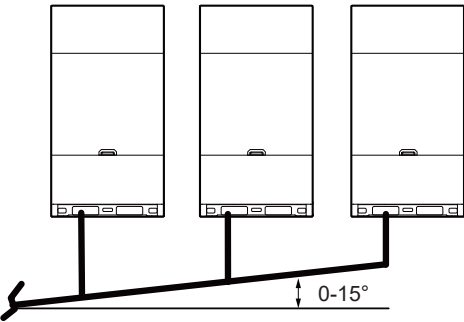

Branch lower than the outdoor unit piping connection and the direction inclination angle is between 0-15°

✓ Correct

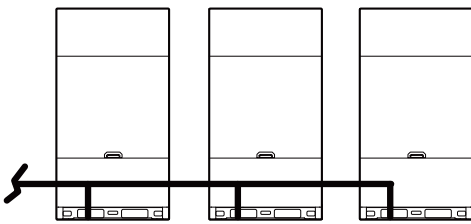

× Incorrect

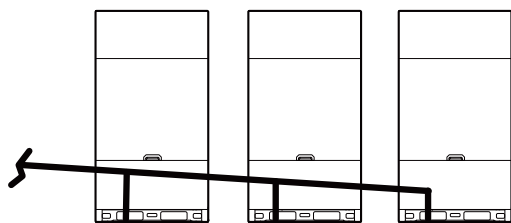

× Incorrect

If the piping length between outdoor units is 2m or more, the oil trap for the gas pipe should be provided so that accumulation of refrigerant oil does not occur.

• Less than 2m

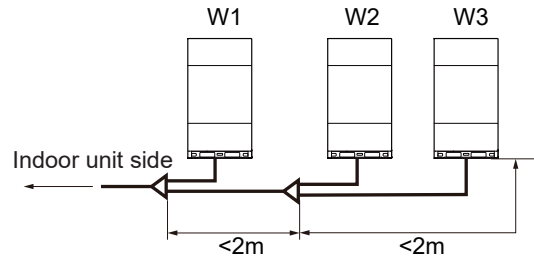

• 2m or more

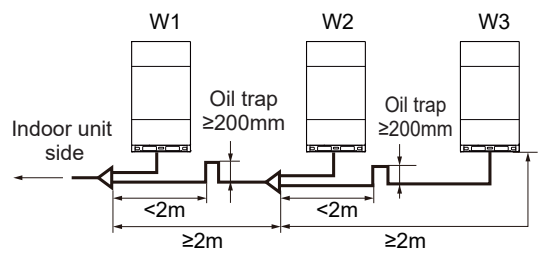

### NOTE

In systems with multiple outdoor units, the units should be placed in order from the largest capacity unit to the smallest capacity unit. The largest capacity unit must be placed on the first branch, and be set as the master unit, while the others should be set as slave units. The capacity of outdoor units W1, W2 and W3 must meet the following conditions:  $W1 \geq W2 \geq W3$ .

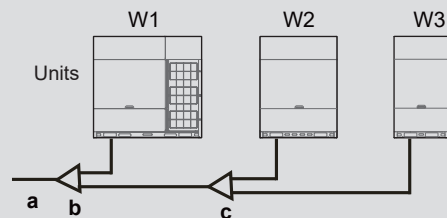

a To indoor unit

b Outdoor branch joint assembly (first branch joint)

c Outdoor branch joint assembly (second branch joint)

## 4.4 Selecting and Preparing the Electrical Wiring

### 4.4.1 Safety device requirements

1. Select the wire diameters (minimum value) individually for each unit based on Table 4.13 and Table 4.14, where the rated current in Table 4.13 refers to MCA in Table 4.14. If the MCA exceeds 63A, the wire diameters should be selected according to the national wiring regulation.
2. The maximum allowable voltage range variation between phases is 2%.
3. Select circuit breakers that have a contact separation in all poles not less than 3 mm providing full disconnection, where MFA is used to select the current circuit breakers and residual current operation breakers:

Table 4.13

Rated current of appliance (A)	Nominal cross-sectional area (mm <sup>2</sup> )	
	Flexible cords	Cable for fixed wiring
≤ 3	0.5 and 0.75	1 to 2.5
> 3 and ≤ 6	0.75 and 1	1 to 2.5
> 6 and ≤ 10	1 and 1.5	1 to 2.5
> 10 and ≤ 16	1.5 and 2.5	1.5 to 4
> 16 and ≤ 25	2.5 and 4	2.5 to 6
> 25 and ≤ 32	4 and 6	4 to 10
> 32 and ≤ 50	6 and 10	6 to 16
> 50 and ≤ 63	10 and 16	10 to 25

Table 4.14

System	Outdoor Unit				Power Current			Compressor		Fan Motor	
	Voltage (V)	Frequency (Hz)	Min. (V)	Max. (V)	MCA (A)	TOCA (A)	MFA (A)	MSC (A)	RLA (A)	Power (kW)	FLA (A)
8HP	380-415	50	342	440	17.0	20.7	20	-	12.0	0.56	1.7
10HP	380-415	50	342	440	18.8	22.5	25	-	14.0	0.56	1.7
12HP	380-415	50	342	440	23.0	26.8	32	-	17.5	0.56	1.8
14HP	380-415	50	342	440	26.2	31.0	32	-	20.5	0.92	2.8
16HP	380-415	50	342	440	31.4	36.2	40	-	24.0	0.92	2.8
18HP	380-415	50	342	440	33.0	38.0	40	-	31.0	0.56+0.56	1.8+1.8
20HP	380-415	50	342	440	40.5	46.1	50	-	36.0	0.56+0.56	1.8+1.8
22HP	380-415	50	342	440	41.5	47.1	50	-	38.0	0.56+0.56	2.0+2.0
24HP	380-415	50	342	440	46.0	52.0	63	-	43.5	0.56+0.56	2.0+2.0
26HP	380-415	50	342	440	48.0	54.0	63	-	19.0+19.2	0.92+0.92	2.1+2.1
28HP	380-415	50	342	440	51.0	57.4	63	-	19.5+29.3	0.92+0.92	2.1+2.1
30HP	380-415	50	342	440	56.8	63.2	80	-	20.0+31.2	0.92+0.92	2.2+2.2
32HP	380-415	50	342	440	57.0	63.4	80	-	22.0+33.0	0.92+0.92	2.2+2.2

### **i** INFORMATION

Phase and frequency of power supply system: 3N-50Hz, Voltage: 380-415V

Abbreviations:

MCA: Maximum Circuit Amps; TOCA: Total Over-current Amps; MFA: Maximum Fuse Amps; MSC: Maximum Starting Current (A); RLA: Rated Load Amps; FLA: Full Load Amps.

- Units are suitable for use in electrical systems where voltage supplied to unit terminals is not below or above listed range limits. The maximum allowable voltage variation between phases is 2%.
- Select wire size based on the value of MCA.
- TOCA indicates the total overcurrent amps value of each OC set.
- MFA is used to select overcurrent circuit breakers and residual-current circuit breakers.
- MSC indicates the maximum current on compressor start-up in amps.
- RLA is based on the following conditions: indoor temperature 27°C DB, 19°C WB; outdoor temperature 35°C DB.

## 5 OUTDOOR UNIT INSTALLATION

### 5.1 Overview

This chapter includes the following information:

- Open the unit
- Outdoor unit installation
- Welding refrigerant piping
- Refrigerant piping check
- Refrigerant charging
- Electrical Wiring

### 5.2 Opening the Unit

#### 5.2.1 Opening the outdoor unit

- Remove four mounting screws A on the middle panel;

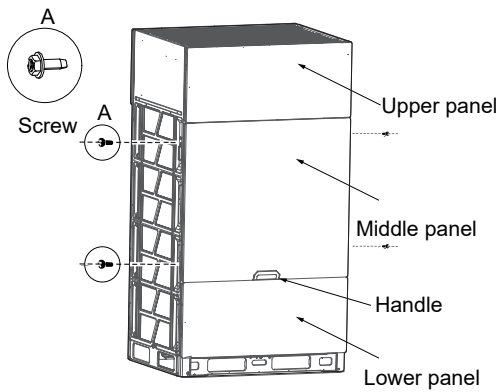

Figure 5.1

- Hold the parts indicated as B in the figure on the middle panel and gently pull the panel outward. The hooks on the panel are hung on the holes of the side plate.

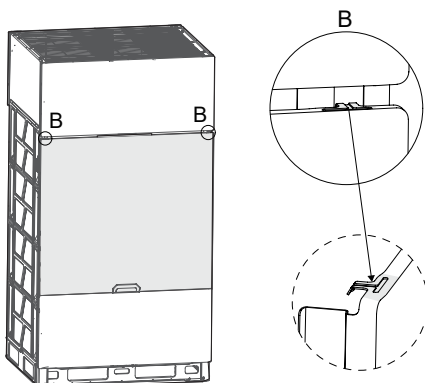

Figure 5.2

- Hold the panel with one hand and lift the handle with the other hand to disengage the left and right hooks from the holes of the side plate in turn.

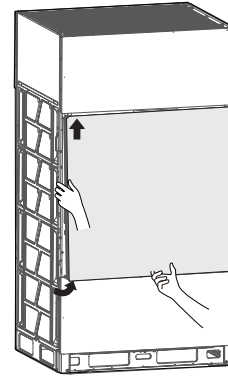

Figure 5.3

#### NOTE

When removing the panels, remove the middle panel first, and then the other panels. Similarly, when installing the panels, install other panels first, and then the middle panel.

#### 5.2.2 Opening the electric control box

- Loosen the two screws (by turning them 1 to 3 turns counter-clockwise) from the cover of the electric control box.
- Lift the cover upwards for 7 to 8mm, and then turn it outwards for 10 to 20mm.
- Slide down the cover to remove it.

8-24HP

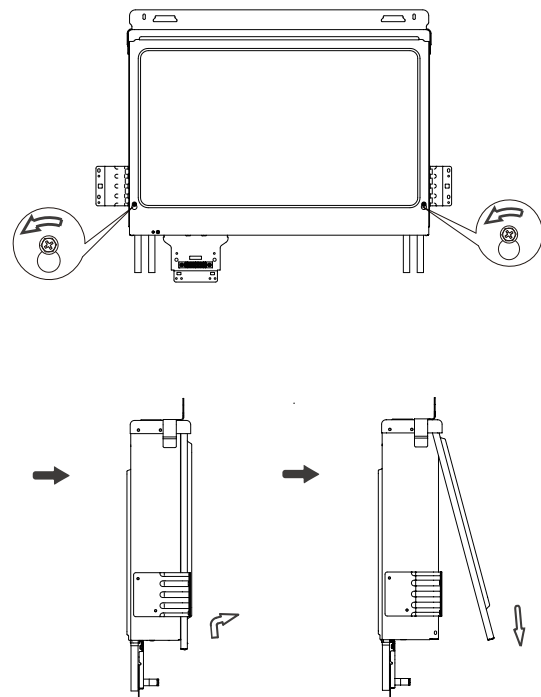

Figure 5.4

26-32HP

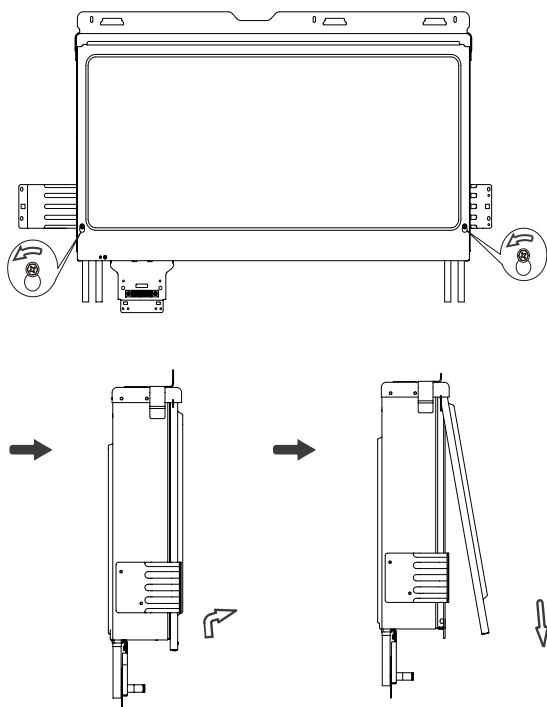

Figure 5.5

**NOTE**

The cover is clamped to the electric control box, so be sure to remove it slowly during disassembly.

**WARNING**

- To remove the entire electric control box, discharge the refrigerant from the system first, and then disconnect the pipe connecting the refrigerant radiator at the bottom of the electric control box, and remove all wiring connecting the electric control box and the internal components of the air conditioner.
- The images shown here are for illustrative purposes only and may differ from the actual product due to model differences and product upgrades. Please refer to the actual product.

**5.2.3 Internal components of electrical box**

8-16HP

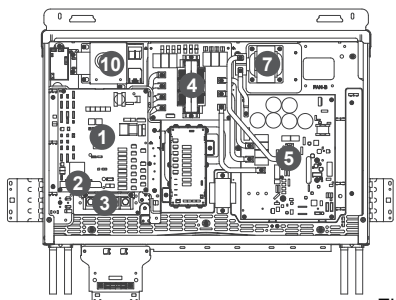

Figure 5.6

18-24HP

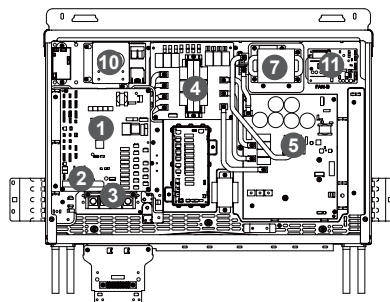

Figure 5.7

26-32HP

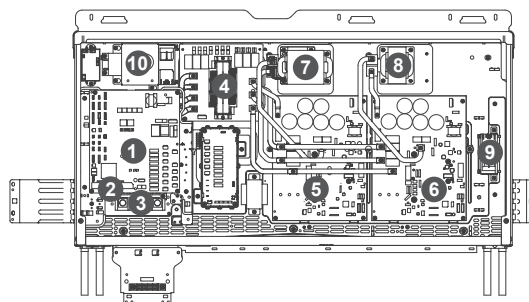

Figure 5.8

The heat radiator piping of the refrigerant is connected to the system.

- (1) Main control board
- (2) Communication terminal block
- (3) Terminal block
- (4) AC filter board
- (5) Compressor & Fan drive board A
- (6) Compressor & Fan drive board B
- (7) Reactance
- (8) Reactance
- (9) Cooling fan
- (10) Cooling fan
- (11) Fan drive board

**CAUTION**

- Make sure the power supply is off before you carry out any electric control installation and maintenance work.
- To remove the entire electric control box, first discharge the refrigerant from the system, and disconnect the pipe connecting the refrigerant radiator at the bottom of the electric control box. At the same time, remove all wiring connecting the electric control box and the internal components of the air conditioner.
- The images shown here are for illustrative purposes only and may differ from the actual product due to model differences and product upgrades. Please refer to the actual product.



## 5.3 Installing the Outdoor Unit

### 5.3.1 Preparing the structure for installation

- The base of the outdoor unit must use a solid concrete surface such as cement or a steel beam frame as a base.
- The base must be completely level to ensure that every point of contact is even.
- During installation, make sure the base supports the vertical folds of the front and back under plates of the chassis directly as the vertical folds of the front and back under plates are located where the actual support for the unit load is.
- No gravel layer is required when the base is built on a roof surface, but the sand and cement on the concrete surface must be level, and the base should be chamfered along the edge.
- A water drainage ditch should be set around the base to drain water around the equipment. Potential risk: slipping.
- Check the load-bearing capacity of the roof to make sure it can support the load.
- When you choose to install the piping from the bottom, the base height should be above 200mm.
- Make sure the base where the unit is installed is strong enough to prevent vibrations and noise.

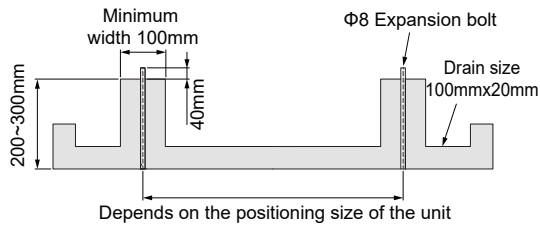

Figure 5.9

Use four ground bolts (M8) to secure the unit in place. The best option is to screw in the ground bolt until it is embedded in the base surface by at least 3 threads.

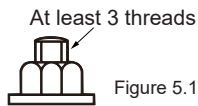

Figure 5.10

Please refer to the figure below for the installation position of expansion bolts.

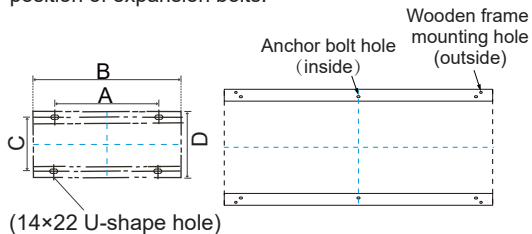

Figure 5.11

Table 5.1

Unit: mm

HP	Size	A	B	C	D	U-shaped hole
8-16HP		705	960	710	850	Φ14*22
18-24HP		1105	1360	710	850	
26-32HP		1645	1900	710	850	

### 5.3.2 Outdoor unit installation space

Make sure there is sufficient space around the unit for maintenance work, and the minimum space for air inlet and air outlet is reserved (see below to select a feasible method).

#### NOTE

- Ensure there is enough space for maintenance. The units in the same system must be placed at the same height.
- Outdoor units must be spaced so that sufficient air may flow through each unit. Sufficient airflow across heat exchangers is essential for outdoor units to function properly.

- For single installation

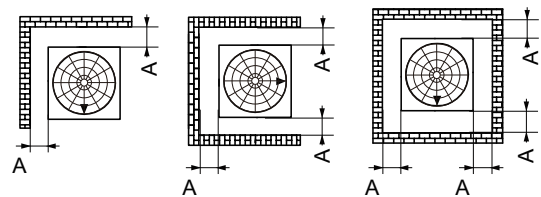

Figure 5.12

- Installation with walls in two directions

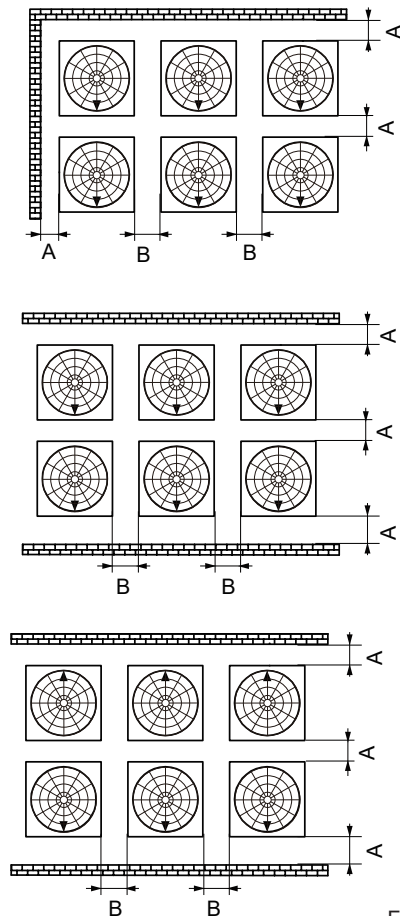

Figure 5.13

- Installation with walls in three directions

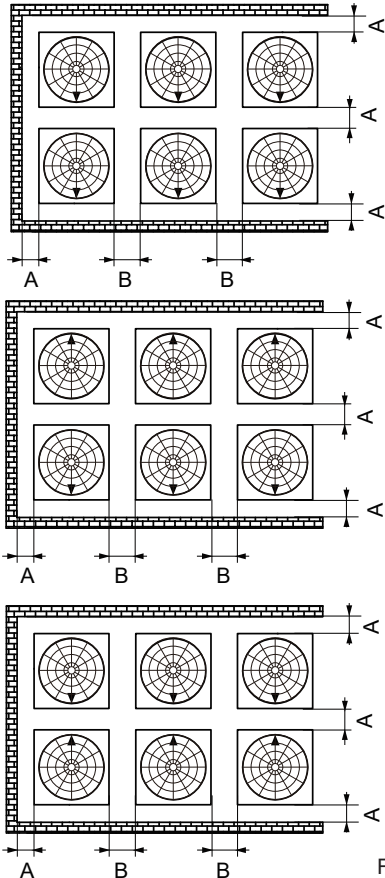

Figure 5.14

- Installation with walls in four directions

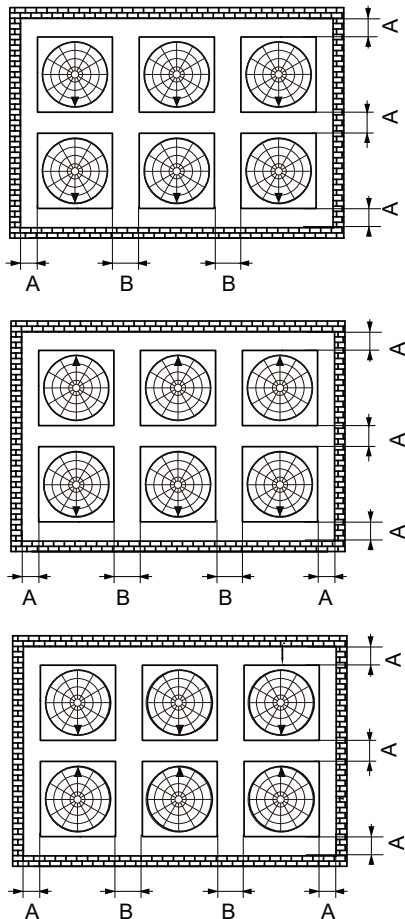

Figure 5.15

### ⚠ CAUTION

- The arrow ▼ indicates the front of the unit in the above figures.
- $A \geq 1000\text{mm}$ ,  $500\text{mm} \geq B \geq 100\text{mm}$ .
- The dimensions in the above figures provide sufficient space for operation and maintenance under normal operating conditions (refrigeration mode at an outdoor temperature of  $35^\circ\text{C}$ ).
- If the outdoor temperature is higher and ventilation short circuiting may occur, choose the most suitable dimensions by calculating the return air flow.
- Keep the inlet and outlet of each ODU open and avoid interference.
- If there is an obstacle in the space over the unit, the four sides of the unit should be open.

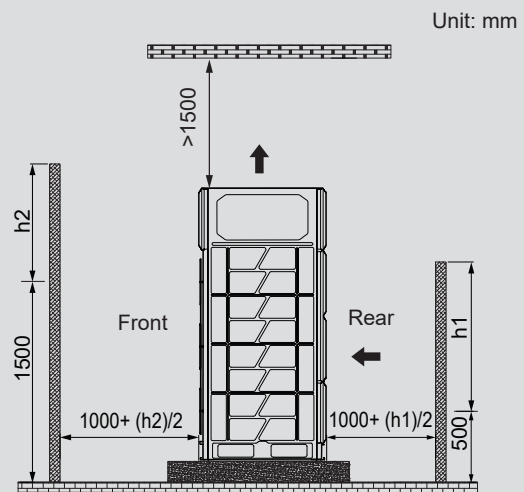

Figure 5.16

- If there are no walls in front of or behind the unit, it is necessary to reserve a space of 1000mm on both sides.
- If the front wall is higher than 1500mm, a space of at least  $(1000 + (h_2)/2)$  mm is required at the front.
- If the rear wall is higher than 500mm, a space of at least  $(1000 + (h_1)/2)$  mm is required at the back.
- When the space above the unit is less than 1500mm, an air ducting device shall be installed to prevent ventilation from short circuiting.
- When the space over the unit is greater than 1500mm, an air ducting device shall be installed if the air circulation is not smooth at the top of the unit.

### ⚠ WARNING

- Do not install the ODU in a confined space.

### 5.3.3 Vibration reduction of outdoor unit

The ODU shall be firmly fixed, and a thick rubber plate or corrugated shock-absorbing rubber cushion with a thickness of more than 20mm and a width of more than 100mm shall be placed between the unit and the foundation. The shock-absorbing rubber cushion must not be placed in a way that only supports the four corners of the unit. The setting requirements are shown in the figure below.

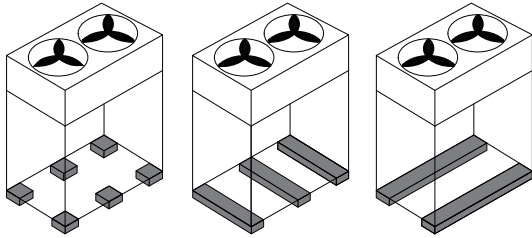

√ Correct

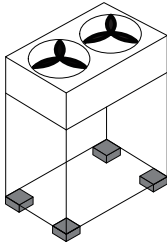

× Incorrect

Figure 5.17

## 5.4 Pipe Welding

### 5.4.1 Things to note when connecting the refrigerant piping

#### ⚠ CAUTION

- During the test, do not exert a force greater than the maximum allowed pressure on the product (as shown on the nameplate).
- Take appropriate precautions to prevent refrigerant leakage. Ventilate the area immediately if the refrigerant leaks. Possible risks (An excessively high concentration of refrigerant in an enclosed area can lead to anoxia (oxygen deficiency); the refrigerant gas may produce a toxic gas if it comes in contact with an open flame.)
- Refrigerant must be recovered. Do not release it into the environment. Use professional fluorine extraction equipment to extract the refrigerant from the unit.

#### 💡 NOTE

- Make sure the refrigerant piping is installed in accordance with applicable laws.
- Make sure the piping and connections are not placed under pressure.
- After all the piping connections have been completed, check to make sure there is no gas leak. Use nitrogen to conduct the leak check for gas.

### 5.4.2 Connect refrigerant piping

Before the refrigerant piping is connected, make sure the indoor units and outdoor units are installed properly. Refrigerant piping connection procedures include:

- Connecting refrigerant piping to the outdoor unit
- Connecting refrigerant piping to the indoor unit (refer to the installation manual of the indoor unit)
- Connecting the VRF piping assembly
- Assembly for connecting refrigerant piping branch joint
- Bear in mind the following guidelines:
  - Braze
  - Stop valve is used correctly

### 5.4.3 Outdoor refrigerant connecting pipe position

The outdoor refrigerant connecting pipe position is shown in the following figure.

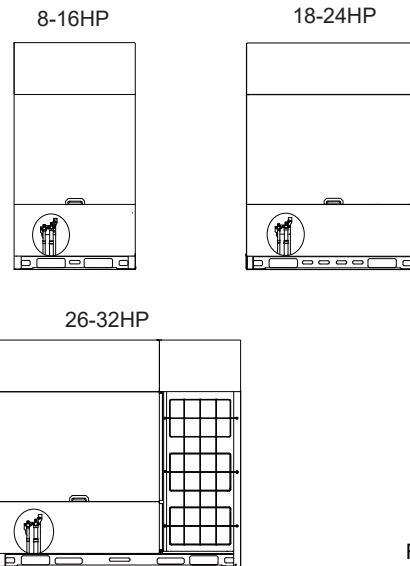

Figure 5.18

### 5.4.4 Connecting refrigerant piping to the outdoor unit

#### 💡 NOTE

- Note the precautions when connecting the field piping for the refrigerant. Add brazing material.
- Use the attached piping fittings when working on the pipeline engineering on site.
- After installation, make sure the piping does not come in contact with each other or the chassis.

The fittings provided as accessories can be used to complete the connection from the stop valve to the field piping.

### 5.4.5 Connecting VRF piping assembly

#### CAUTION

- Incorrect installation will cause the unit to malfunction

The branch joints should be as level as possible, and the angular error must not exceed 10°.

U type branch joint

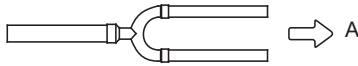

A-direction view

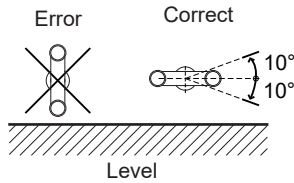

Figure 5.19

The branch joints come in different pipe diameters, which can be easily matched with different pipe diameters. When connecting pipes, select the pipe section with the appropriate pipe diameter, cut it in the middle with a pipe cutter and remove burrs, as shown in the figure below.

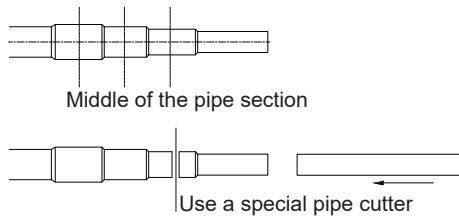

Figure 5.20

The length of the straight pipe section between the contiguous branch pipes shall be no less than 500mm. The straight pipe section behind the branch pipe end shall be no less than 500mm. The length of straight pipe between two right angle bends shall be no less than 500mm.

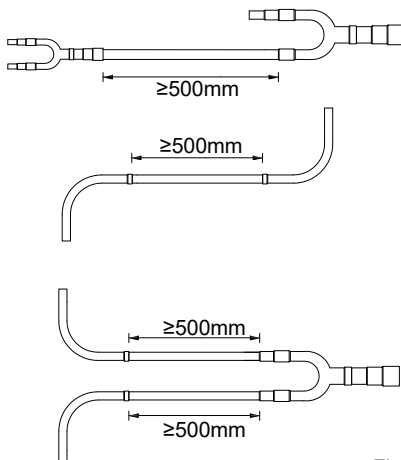

Figure 5.21

When there are multiple outdoor units, the branch joints must not be higher than the refrigerant piping as shown below:

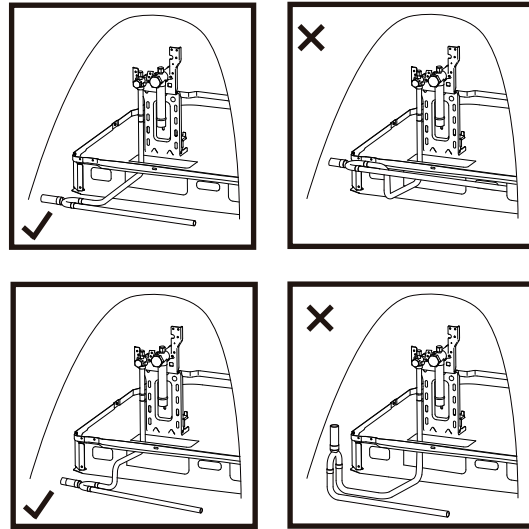

Figure 5.22

### 5.4.6 Brazing

- During brazing, use nitrogen as protection to prevent the formation of a large amount of oxide film in the pipes. This oxide film will have adverse effects on the valves and compressors in the cooling system, and may hamper normal operations.
- Use the reducing valve to set the nitrogen pressure to 0.02-0.03 MPa (a pressure that can be felt by the skin).

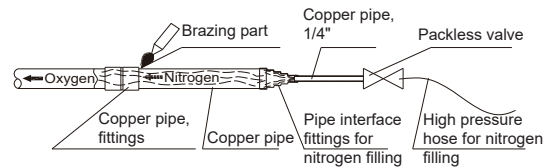

Figure 5.23

- Do not use antioxidants when brazing the pipe joints.
- Use copper-phosphorus alloys (BCuP) when brazing copper and copper, and no flux is required. When brazing copper and other alloys, flux is required. Flux produces an extremely harmful effect on the refrigerant piping system. For example, using a chlorine-based flux is used may corrode the pipes, and when the flux contains fluorine, it will degrade the frozen oil.
- During brazing, protect the valve mounting plate and wires from burning.

### 5.4.7 Connecting stop valves

#### Stop valves

- The following figure shows the names of all parts required for the installation of the stop valves.
- Stop valves are closed when unit is shipped from the factory.

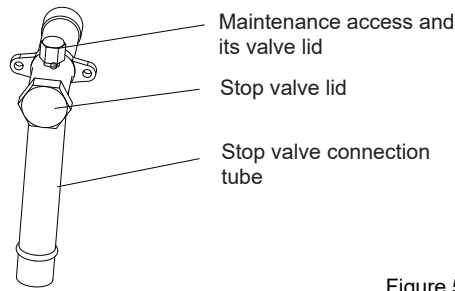

Figure 5.24

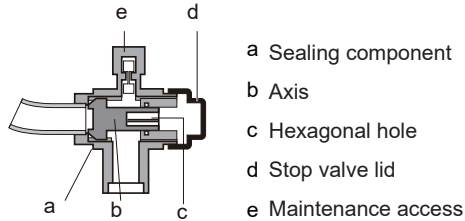

Figure 5.25

### Using of a stop valve

1. Remove the stop valve lid.
2. Insert the hex wrench into the stop valve, and rotate the stop valve counter-clockwise.
3. Stop turning when the stop valve cannot be rotated further.

Result: Valve is now open.

The fastening torque of the stop value is shown in Table 5-2. Insufficient torque may cause the refrigerant to leak.

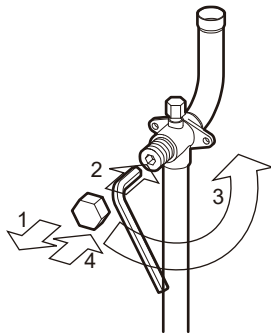

Figure 5.26

### Closing the stop valve

1. Remove the stop valve lid.
2. Insert the hex wrench into the stop valve, and rotate the stop valve clockwise.
3. Stop turning when the stop valve cannot be rotated further.

Result: Valve is now closed.

Direction to close:

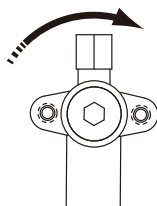

Figure 5.27

Fastening torque

Table 5.2

Stop valve size (mm)	Tightening torque / N.m (turn clockwise to close)	
	Axis	
	Valve body	
Φ12.7	9-30	
Φ15.9	12-30	
Φ19.1		
Φ22.2	16-30	
Φ25.4	24-30	
Φ28.6		
Φ31.8	25-35	
Φ35.0		

## 5.5 Flushing Pipes

To remove dust, other particles and moisture, which could cause compressor malfunction if not flushed out before the system is run, the refrigerant piping should be flushed using nitrogen. Pipes should be flushed once the piping connections have been completed except for the final connections to the indoor units. That is, flushing should be performed once the outdoor units have been connected but before the indoor units are connected.

### ⚠ CAUTION

Only use nitrogen for flushing. Using carbon dioxide risks leaving condensation in the piping. Oxygen, air, refrigerant, flammable gases and toxic gases must not be used for flushing. Use of such gases may result in fire or explosion.

The liquid and gas sides can be flushed simultaneously; alternatively, one side can be flushed first and then Steps 1 to 9 repeated for the other side. The flushing procedure is as follows:

1. Cover the inlets and outlets of the indoor units to prevent dirt from getting blown in while flushing the pipe. (Pipe flushing should be carried out before connecting the indoor units to the piping system.)
2. Attach a pressure reducing valve to a nitrogen cylinder.
3. Connect the pressure reducing valve outlet to the inlet on the liquid (or gas) side of the outdoor unit.
4. Use blind plugs to block all liquid (gas) side openings, except for the opening at the indoor unit which is furthest from the outdoor units ("Indoor unit A" in Figure 5.28).
5. Start to open the nitrogen cylinder valve and gradually increase the pressure to 0.5Mpa.
6. Allow time for nitrogen to flow as far as the opening at indoor unit A.
7. Flush the first opening:
  - a) Using suitable material, such as a bag or cloth, press firmly against the opening at indoor unit A.
  - b) When the pressure becomes too high to block with your hand, suddenly remove your hand allowing the gas to rush out.
  - c) Repeatedly flush in this manner until no further dirt or moisture is emitted from the piping. Use a clean cloth to check for dirt or moisture being emitted. Seal the opening once it has been flushed.

8.Flush the other openings in the same manner, working in sequence from indoor unit A towards the outdoor units. Refer to Figure 5.28.

9.Once flushing is complete, seal all openings to prevent dust and moisture from entering.

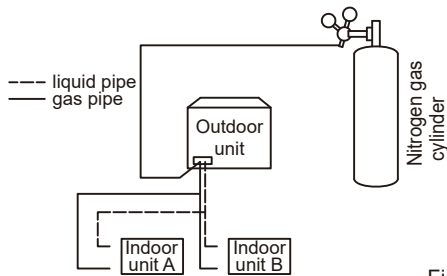

Figure 5.28

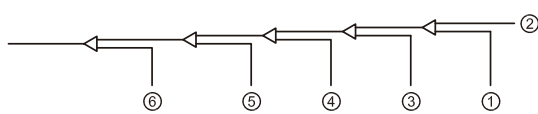

Figure 5.29

## 5.6 Gas Tightness Test

To prevent faults caused by refrigerant leakage, a gas tightness test should be performed before system commissioning.

### CAUTION

- Only dry nitrogen should be used for gas tightness testing. Oxygen, air, flammable gases and toxic gases must not be used for gas tightness testing. Use of such gases may result in fire or explosion.
- Make sure that all the outdoor unit stop valves are firmly closed.

The gas tightness test procedure is as follows:

1.Charge the indoor piping with nitrogen at 0.3Mpa through the needle valves on the liquid and gas stop valves and leave for at least 3 minutes (do not open the liquid or gas stop valves). Observe the pressure gauge to check for large leakages. If there is a large leakage, the pressure gauge will drop quickly.

2.If there are no large leakages, charge the piping with nitrogen at 1.5Mpa and leave for at least 3 minutes. Observe the pressure gauge to check for small leakages. If there is a small leakage, the pressure gauge will drop noticeably.

3.If there are no small leakages, charge the piping with nitrogen at 4.2 MPa and leave for at least 24 hours to check for micro leakages. Micro leakages are difficult to detect. To check for micro leakages, allow for any change in ambient temperature over the test period by adjusting the reference pressure by 0.01Mpa per 1°C of temperature difference. Adjusted reference pressure = Pressure at pressurization + (temperature at observation – temperature at pressurization) x 0.01Mpa. Compare the observed pressure with the adjusted reference pressure. If they are the same, the piping has passed the gas tightness test. If the observed pressure is lower than the adjusted reference pressure, the piping has a micro leak.

4.If leakage is detected, refer to the section of the manual titled “Leak detection”. Once the leak has been found and fixed, the gas tightness test should be repeated.

5.If not continuing straight to vacuum drying once the gas tightness test is complete, reduce the system pressure to 0.5-0.8MPa and leave the system pressurized until ready to carry out the vacuum drying procedure.

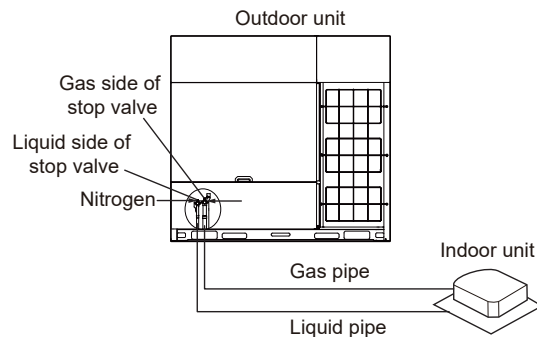

Figure 5.30

### Leak detection

The general methods for identifying the source of a leak are as follows:

1. Audio detection: relatively large leaks are audible.
2. Touch detection: place your hand at joints to feel for escaping gas.
3. Soapy water detection: small leaks can be detected by the formation of bubbles when soapy water is applied to a joint.

## 5.7 Vacuum Drying

Vacuum drying should be performed to remove moisture and non-condensable gases from the system. Removing moisture prevents ice formation and oxidization of copper piping or other internal components. The presence of ice particles in the system will cause abnormal operation, but particles of oxidized copper can cause compressor damage. The presence of non-condensable gases in the system will lead to pressure fluctuations and poor heat exchange performance.

Vacuum drying also provides additional leak detection (in addition to the gas tightness test).

### CAUTION

- Before performing vacuum drying, make sure that all the outdoor unit stop valves are firmly closed.
- Once the vacuum drying is complete and the vacuum pump is stopped, the low pressure in the piping could suck vacuum pump lubricant into the air conditioning system. The same could happen if the vacuum pump stops unexpectedly during the vacuum drying procedure. Mixing pump lubricant with compressor oil could cause the compressor to malfunction. Therefore a check valve should be used to prevent vacuum pump lubricant from seeping into the piping system.

During vacuum drying, a vacuum pump is used to lower the pressure in the piping to the extent that any moisture present evaporates. At 5 mm Hg (755 mm Hg below typical atmospheric pressure) the boiling point of water is 0°C. Therefore a vacuum pump capable of maintaining a pressure of -756 mm Hg or lower should be used. Using a vacuum pump with a discharge over 4 L/s and a precision level of 0.02 mm Hg is recommended. The vacuum drying procedure is as follows:

1. Connect the vacuum pump through a manifold with a pressure gauge to the service port of all stop valves.
2. Start the vacuum pump and then open the manifold valves to start vacuuming the system.
3. After 30 minutes, close the manifold valves.
4. After a further 5 to 10 minutes check the pressure gauge. If the gauge has returned to zero, check for leakages in the refrigerant piping.
5. Re-open the manifold valves and continue vacuum drying for at least 2 hours and until a pressure difference of 0.1 MPa or more has been achieved. Once the pressure difference of at least 0.1 MPa has been achieved, continue vacuum drying for 2 hours. Close the manifold valves and then stop the vacuum pump. After 1 hour, check the pressure gauge. If the pressure in the piping has not increased, the procedure is finished. If the pressure has increased, check for leakages.
6. After vacuum drying, keep the manifold connected to the master unit stop valves, in preparation for refrigerant charging.

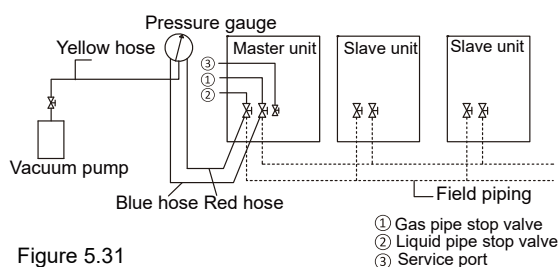

Figure 5.31

## 5.8 Piping Insulation

After the leak test and the vacuum drying are completed, the pipe must be insulated. Considerations:

- Make sure the refrigerant piping and branch joints are completely insulated.
- Make sure the liquid and gas pipes (for all units) are insulated.
- Use heat-resistant polyethylene foam for the liquid pipes (able to withstand temperature of 70°C), and polyethylene foam for the gas pipes (able to withstand temperatures of 120°C).
- Reinforce the insulation layer of the refrigerant piping based on the installation environment.

### 5.8.1 Selection of insulation material thickness

Condensed water may form on the surface of the insulation layer.

Table 5.3

Piping size	Humidity<80%RH Thickness	Humidity≥80%RH Thickness
Φ6.4~38.1 mm	≥ 15 mm	≥ 20 mm
Φ41.3~54.0 mm	≥ 20 mm	≥ 25 mm

### 5.8.2 Pipe wrapping

To avoid condensation and water leakage, the connecting pipe must be wrapped with tape to ensure isolation from the air.

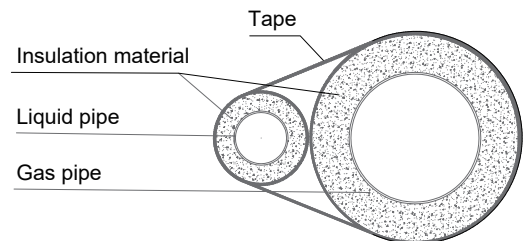

Figure 5.32

When wrapping insulation tape, each circle should press half of the previous circle of tape. Do not wrap the tape too tightly to avoid reducing the thermal insulation effect.

After completing the pipe insulation work, seal the holes in the wall with sealing material.

### 5.8.3 Protective measures for the pipeline

The refrigerant pipe will swing, expand or shrink during operations. If the pipe is not fixed, the load will be concentrated in a certain part, which may cause the refrigerant pipe to deform or rupture.

The suspended connecting pipes shall be well supported, and the distance between supports shall not exceed 1m.

The outdoor pipes shall be protected against accidental damage. If the length of the pipe exceeds 1m, a gusset plate must be added for protection.

## 5.9 Refrigerant Charging

### WARNING

- Use only R410A as the refrigerant. Other substances may cause explosions and accidents.
- R410A contains fluorinated greenhouse gases, and the GWP value is 2088. Do not discharge the gas into the atmosphere.
- When charging the refrigerant, make sure you wear protective gloves and safety glasses. Be careful when you open the refrigerant piping.

### NOTE

- If the power supply of some units is off, the charging program cannot be completed normally.
- If this is a multi-unit outdoor system, the power supply for all outdoor units should be turned on.
- Make sure the power supply is turned on 12 hours before operations so that the crankcase heater is properly energized. This is also to protect the compressor.
- Make sure all connected indoor units have been identified.
- Charge the refrigerant only after the system has not failed the gas tightness tests and vacuum drying.
- Volume of refrigerant charged must not exceed the designed amount.

### Calculating the additional refrigerant charge calculation for liquid piping (R1 kg)

The additional refrigerant charge required depends on the lengths and diameters of the outdoor and indoor liquid pipes. The table below shows the additional refrigerant charge required per meter of equivalent pipe length for different diameters of pipe. The total additional refrigerant charge is obtained by summing the additional charge requirements for each of the outdoor and indoor liquid pipes, as in the following formula, where T1 to T8 represent the equivalent lengths of the pipes of different diameters. Assume 0.5m for the equivalent pipe length of each branch joint.

Table 5.4

Liquid piping Diameter (mm OD)	Additional refrigerant charge per meter of equivalent length of liquid piping (kg)
Φ6.35	0.022
Φ9.52	0.057
Φ12.7	0.110
Φ15.9	0.170
Φ19.1	0.260
Φ22.2	0.360
Φ25.4	0.520
Φ28.6	0.680

Additional refrigerant charge R1 (kg) = (T1@Φ6.35) × 0.022 + (T2@Φ9.52) × 0.057 + (T3@Φ12.7) × 0.110 + (T4@Φ15.9) × 0.170 + (T5@Φ19.1) × 0.260 + (T6@Φ22.2) × 0.360 + (T7@Φ25.4) × 0.520 + (T8@Φ28.6) × 0.680.

### Calculating the additional refrigerant charge quantity for outdoor unit (R2 kg)

The additional refrigerant charge is required depending on the capacity of connected outdoor units. In case of a multi-outdoor-unit system, add the sum of the individual outdoor unit charge amount. Select the refrigerant quantity for each outdoor unit from the following table.

Table 5.5

HP	8	10	12	14	16	18	20	22	24	26	28	30	32
Additional refrigerant Charge (kg)	0	0	0	0	0	0	0	0	0	7	9	9	9

The additional refrigerant charge (R2 kg) = W1+W2+W3  
W1: master unit additional refrigerant charge amount;  
W2: Slave unit 1 additional refrigerant charge amount;  
W3: Slave unit 2 additional refrigerant charge amount;

The example below illustrates the piping selection procedure for a system consisting of three outdoor units (32HP+32HP+24HP). Based on the capacity of each outdoor unit, Select the refrigerant quantity from the table 5.4, W1=9kg; W2=9kg; W3=0kg. The additional refrigerant charge quantity for outdoor unit R2 =W1 +W2 +W3 =18kg.

### Calculating the total additional refrigerant charge quantity (R kg).

Total additional refrigerant charge amount (R) is equal to the sum of R1 and R2, calculate the amount of refrigerant to be charged according to the formula below:

$$R \text{ (kg)} = R1 + R2.$$

### Maximum additional refrigerant charge quantity

Ensure that the total additional charge quantity should not exceed the max. additional refrigerant charge quantity.

### NOTE

- Strictly follow the conditions shown in the above calculation method for refrigerant charging amount, and determine that the additional amount shall not exceed the maximum refrigerant additional amount shown in the table 5.6. If the calculated value of additional refrigerant exceeds the limits shown in the table 5.6, the total length of the pipeline construction scheme shall be shortened and the refrigerant charging amount shall be recalculated to meet the requirements shown in the table 5.6.
- The maximum refrigerant addition shown in the table 5.6 is based on the recommended combination.

Table 5.6

HP	Maximum additional refrigerant charge quantity (kg)	HP	Maximum additional refrigerant charge quantity (kg)
8	30.9	18	41.9
10	32.6	20	41.9
12	35.5	22	41.9
14	37.0	24	41.9
16	38.8	26	69.0



Table 5.6

HP	Maximum additional refrigerant charge quantity (kg)	HP	Maximum additional refrigerant charge quantity (kg)
28	69.3	64	74.6
30	69.6	66	74.9
32	69.9	68	92.7
34	70.2	70	93.1
36	70.5	72	93.4
38	70.8	74	93.7
40	71.1	76	93.9
42	71.4	78	94.2
44	71.6	80	94.6
46	72.0	82	94.8
48	72.3	84	95.1
50	72.5	86	95.4
52	72.8	88	95.7
54	73.1	90	96.0
56	73.4	92	96.2
58	73.7	94	114.2
60	74.0	96	114.4
62	74.3		

**NOTE**

- The refrigerant charge of the system must be less than 100 kg. This means that in case the calculated total refrigerant charge is equal to or more than 100 kg you must divide your multiple outdoor system into smaller independent systems, each containing less than 100 kg refrigerant charge. For factory charge, refer to the unit name plate.

**Refrigerant charge amount of outdoor unit before shipment (R0 kg)**

For factory charge of outdoor unit, refer to the outdoor unit name plate. In case of a multi-outdoor-unit system, calculate the total refrigerant charge before shipment of the outdoor units to be combined.

**Calculate the refrigerant charge of the system (Rt kg)**

The total refrigerant of the system (Rt) = refrigerant before shipment (R0) + additional refrigerant in the field (R). The refrigerant charge of the system must be less than 100 kg. If the calculated total refrigerant charge is equal to or more than 100 kg you must divide your multiple outdoor system into smaller independent systems, each containing less than 100 kg refrigerant charge.

The procedure for adding refrigerant is as follows:

1. Calculate additional refrigerant charge R (kg).
2. Place a tank of R410A refrigerant on a weighing scale. Turn the tank upside down to ensure the refrigerant is charged in a liquid state. (R410A is a blend of two different chemical compounds. Charging gaseous R410A into the system could mean that the refrigerant charged is not of the correct composition).
3. After vacuum drying, the blue and red pressure gauge hoses should still be connected to the pressure gauge and the master unit stop valves.
4. Connect the yellow hose from the pressure gauge to the R410A refrigerant tank.
5. Open the valve where the yellow hose meets the pressure gauge, and open the refrigerant tank slightly to let the refrigerant eliminate the air. Caution: open the tank slowly to avoid freezing your hand.
6. Set the weighing scale to zero.
7. Open the three valves on the pressure gauge to begin charging refrigerant.

8. When the amount charged reaches R (kg), close the three valves. If the amount charged has not reached R (kg) but no additional refrigerant can be charged, close the three valves on the pressure gauge, run the outdoor units in cooling mode, and then open the yellow and blue valves. Continue charging until the full R (kg) of refrigerant has been charged, then close the yellow and blue valves. Note: Before running the system, be sure to complete all the pre-commissioning checks and be sure to open all stop valves as running the system with the stop valves closed would damage the compressor.

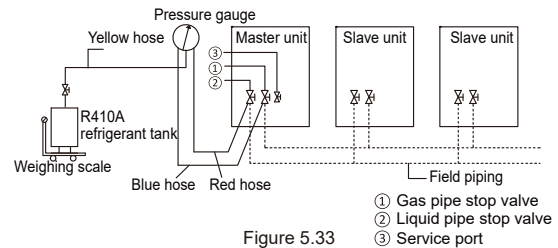

**5.10 Electrical Wiring**

**5.10.1 Electrical wiring precautions**

**WARNING**

- Take note of the risk of electrical shock during installation.
- All the electric wires and components must be installed by installation personnel with the proper electrician certification, and the installation process must comply with applicable regulations.
- Use only wires with copper cores for the connections.
- A main switch or safety device that can disconnect all polarities must be installed, and the switching device can be completely disconnected when the corresponding excessive voltage situation arises.
- Wiring must be carried out in strict accordance with what is stated in the product nameplate.
- Do not squeeze or pull the unit connection, and make sure the wiring is not in contact with the sharp edges of the sheet metal.
- Make sure the grounding connection is safe and reliable. Do not connect the earth wire to public pipes, telephone earth wires, surge absorbers and other places that are not designed for grounding. Improper grounding may cause electrical shock.
- Make sure the fuses and circuit breakers installed meet the corresponding specification requirements.
- Make sure an electric leakage protection device is installed to prevent electrical shock or fires.
- The model specifications and characteristics (anti high-frequency noise characteristics) of the electric leakage protection device are compatible with the unit to prevent frequent tripping.
- Before powering on, make sure the connections between the power cord and terminals of the components are secure, and the metallic cover of the electric control box is closed tightly.

## NOTE

- If the power supply lacks an N phase or there is an error in the N phase, the device will malfunction.
- Some power equipment may have an inverted phase or intermittent phase (such as a generator). For this type of power source, a reverse-phase protection circuit should be installed locally in the unit, as operating in the inverted phase may damage the unit.
- Do not share the same power supply line with other devices.
- The power cord may produce electromagnetic interference so you should maintain a certain distance from the equipment that may be susceptible to such interference.
- Separate the power supply for the indoor and outdoor units.
- For systems with multiple units, make sure a different address is set for each outdoor unit.

### 5.10.2 Wiring layout

The wiring layout comprises the power cords and communication wiring between the indoor and outdoor units. These include the earth lines and the shielded layer of the earth lines of the indoor units in the communication line. See below for the wiring layout of the outdoor unit.

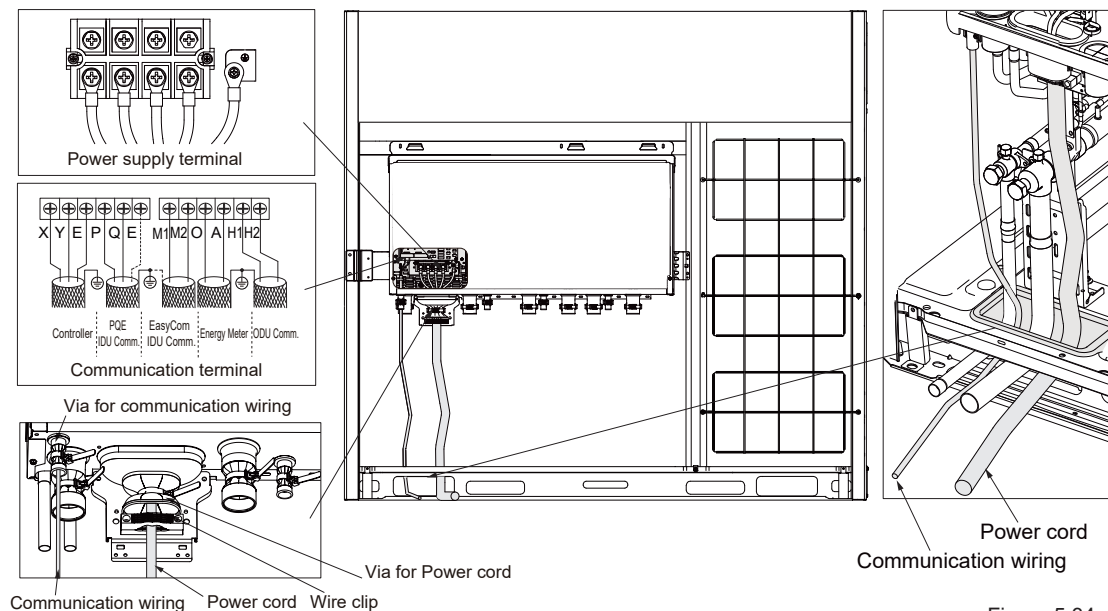

Figure 5.34

## NOTE

- Power cords and communication wiring must be laid out separately, they cannot be placed in the same conduit. Use a power supply conduit to isolate if the current of the power supply is less than 10 A. If the current is greater than 10 A but less than 50 A, the spacing must exceed 500 mm at all times. Otherwise, it may lead to electromagnetic interference.
- Arrange the refrigerant piping, power cords and communication wiring in parallel, but do not tie the communication lines together with the refrigerant piping or power cords.
- Power cords and communication wiring should not come in contact with the internal piping so as to prevent the high temperature of the piping from damaging the wires.
- Once the wiring layout is completed, close the lid tightly to prevent the wiring and terminals from being exposed when the lid is loose.

### 5.10.3 Connecting the power cord

#### NOTE

- Do not connect the power supply to the communication terminal block. Otherwise, the whole system may fail.
- You must first connect the earth line (note that you should use only the yellow-green wire to connect to the earth, and you must turn off the power supply when you are connecting the earth line) before you connect the power cord. Before you install the screws, you must first comb through the path along the wiring to prevent any part of the wiring from becoming exceptionally loose or tight because the lengths of the power cord and earth line are not consistent.
- The wire diameter must comply with specifications, and the terminal should be tightly screwed. At the same time, do not subject the terminal to any external force.

Tighten the terminal with an appropriate screwdriver. Screwdrivers that are too small may damage the terminal head, and cannot tighten it.

- Excessive tightening of the terminal may cause the screw thread to deform and slip, making it impossible to connect the components securely.

- Only use a ring terminal to connect the power cord. Non-standard cable connections will lead to poor contact which may in turn cause exceptional heating and burning. The figure below demonstrates both correct and incorrect connections.

1. Use round-type terminals of the correct specifications to connect the power cable.

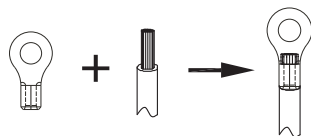

Figure 5.35

#### WARNING

- When inserting the strong-current cables and communication lines into the wiring holes, they must be equipped with wiring across rings to avoid becoming worn.

2. The external power cables are inserted into the wiring holes of the chassis and the electric control box, and the power cables "L1, L2, L3, N" and earth wire are connected to the power wiring board marked with "L1, L2, L3, N" and the grounding screw next to the power wiring board correspondingly.

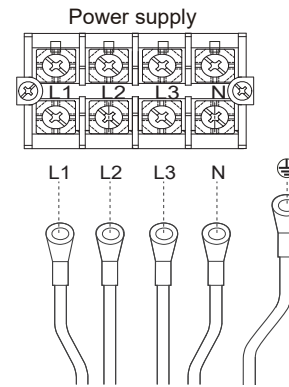

Figure 5.36

#### WARNING

- Terminals must be used for connection. Use round-type terminals of the correct specifications to connect the power cables. Do not directly connect the cable ends. Use the correct terminal, or it may cause over heating and fire.

3. Fasten and fix the cables with wire clips to avoid stress on the terminals.

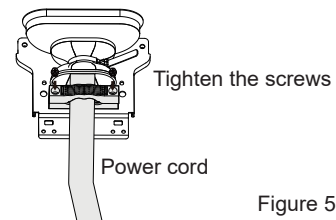

Figure 5.37

4. 8-24 HP use wire clip A with both front and reverse clip; above 24HP use wire clip B, only one type of installation for front clip.

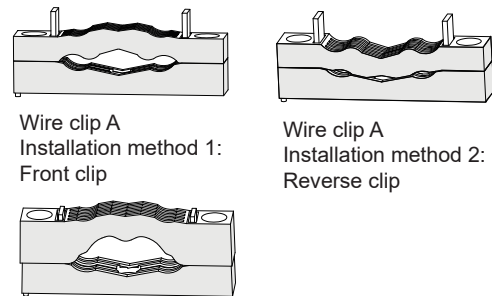

Figure 5.38

5. When installing different types and wire diameters of power cables, different clipping methods are used to ensure that the wire clips can be used to compress the power cables and prevent the terminals from being stressed when the power cables are pulled.

(Note: When using clipping method 1, ensure that each power cable is double insulated)

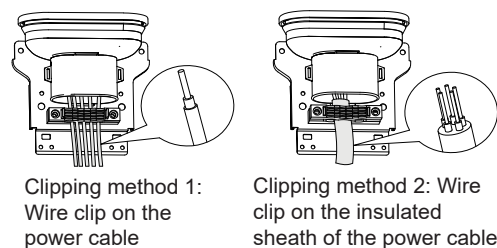

Figure 5.39

- Confirm again that the power phase sequence is correct and properly restore the protecting cover of the power cable.

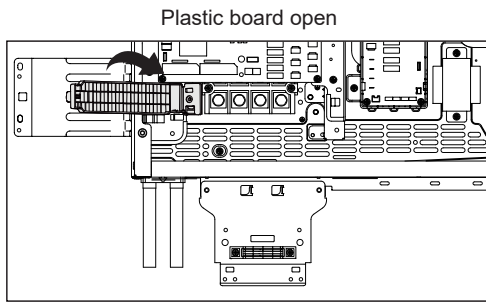

Figure 5.40

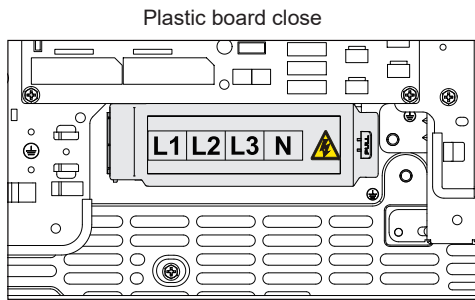

Figure 5.41

- After the communication line and power cable are connected, cover the sheet metal of the electric control box cover, and tie the wiring across the ring tightly with a tightening tape.

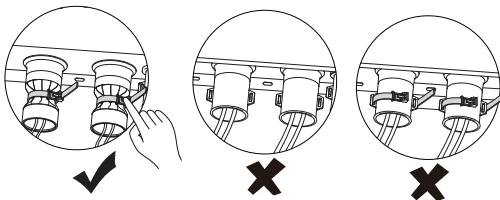

Figure 5.42

### ⚠ WARNING

- Select a proper torque according to the screw size.
- Torque which is too small may cause poor contact, resulting in heating of the terminals and fire. Torque that is too large may damage the screws and power supply terminals.

The size of the screws and recommended torque are as follows:

Table 5.7

Screw specification	Standard value (kgf.cm)/(Nm)
M4	12.2/1.2
M8	61.2/6.0

### ⚠ CAUTION

- During installation, the earth line shall be longer than the current carrying conductor to ensure that when the fixing device is loose, the earth line is still not stressed and can be reliably grounded.
- After installation, close the cover of the electric control box, tighten the screws and seal the wiring hole with a tightening tape. Otherwise, the heat dissipation of the electric control box may be affected, which could shorten the service life of the unit.
- When inserting the strong-current cables and communication lines into the wiring holes, they must be equipped with wiring across rings. Otherwise, they may become worn out by the sheet metal and cause electric leakage or short circuiting.
- The electric control box is fully enclosed. After installation, close the cover of the electric control box, tighten the screws and seal the wiring hole with a tightening tape. Otherwise, the heat dissipation of the electric control box may be affected, which could shorten the service life of the unit.

Outdoor unit wiring diagram

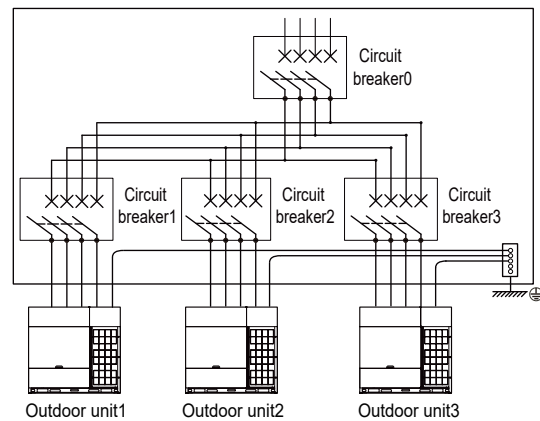

Figure 5.43

### ⚠ WARNING

- Do not connect the earth line of the lightning rod to the unit shell. The earth lines of the lightning rod and the power cable must be configured separately.
- Each unit shall be equipped with a circuit breaker for protection against short circuiting and abnormal overload. In addition, the indoor and ODUs shall be equipped with individual main circuit breakers to connect or disconnect the main power supply of the indoor and ODUs.

## 5.10.4 Connecting the communication wiring

### ⚠ WARNING

- Do not connect the communication line when the power is on.
- Connect the shielding nets at both ends of the shielded wire to the sheet metal “⊕” of the electronic control box.
- Do not connect the power cable to the terminal of the communication line, otherwise, the motherboard will be damaged.
- Do not connect a system with both EasyCom (M1 M2) communication lines and PQ communication lines.
- It is forbidden to reverse the connection of the two communication ports (to up IDU) and (to down IDU) of the repeater.

### ⚠ CAUTION

- On-site wiring must comply with the relevant regulations of the local Country/region and must be completed by professionals.
- The communication lines of the indoor and ODU can only be led out and connected from the master ODU.
- The ODU is often a parallel type of multi module, and the communication lines between the ODUs must be connected in a series.
- When a single communication line is not long enough, the joint must be crimped or soldered, and the copper wire at the joint shall not be exposed.

Before connecting the communication wiring, please select the appropriate communication mode according to the type of indoor unit and refer to the following table.

### 💡 NOTE

For the system, the EMI effect of the communication line M1M2 (or PQE) can be improved by adding a magnetic ring. The installation is shown in the figure below. The magnetic ring needs to be fixed with the communication line (it can be wound for two turns), and placed in the electric control box and secured with a wire clamp.

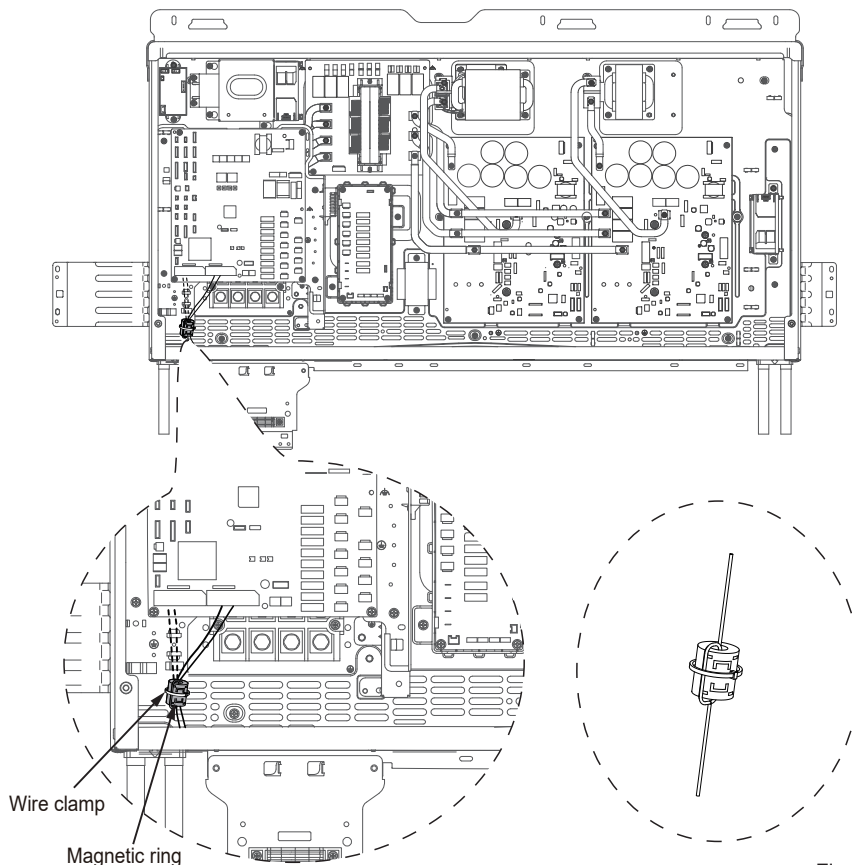

Figure 5.43

Table 5.8 Communication mode

IDU and ODU type	Communication protocol	Optional communication mode between the IDU and ODU
All IDUs and ODUs are V8 series	V8 communication protocol	EasyCom (M1 M2) communication
At least one IDU or ODU is not V8 series	Non-V8 communication protocol	RS-485 (P Q E) communication

Table 5.9 Communication wiring material

Communication mode	Type of wire	Number of cores and wire diameter (mm <sup>2</sup> )	Total length of communication line (m)
RS-485 (P Q E) communication	PVC-sheathed copper-core flexible shielded cable	3x0.75	L≤1200
EasyCom (M1 M2) communication (The IDUs in a system can be powered separately)	PVC-sheathed copper-core flexible shielded cable	2x1.5	L≤600 (2 repeaters are required)
EasyCom (M1 M2) communication (All IDUs in a system must be powered through a uniform power supply)	PVC-sheathed copper-core flexible shielded cable	2x0.75	L≤2000

- EasyCom (M1 M2) communication wiring configuration – IDUs uniform power supplied

$L1+La+Ln \leq 2000m$ . Communication wiring  $2 \times 0.75mm^2$

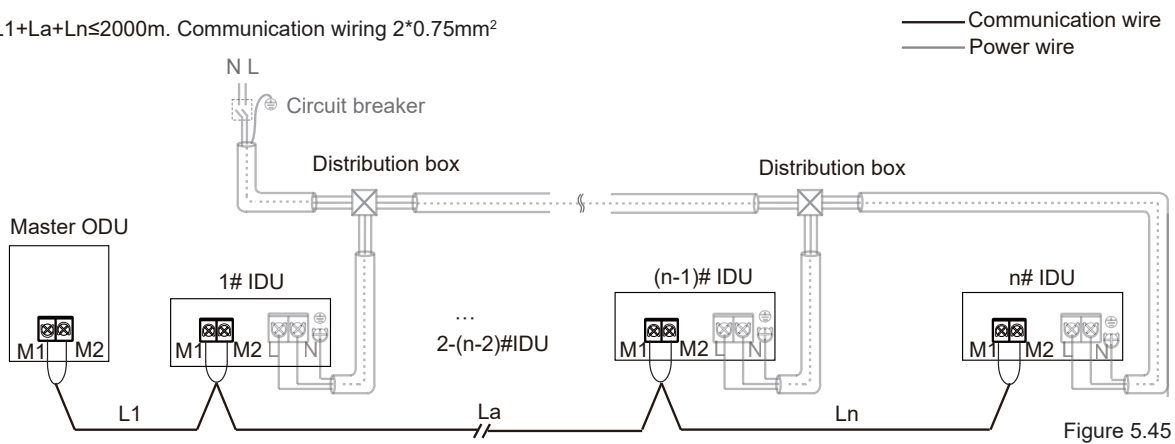

Figure 5.45

## ⚠ CAUTION

- Keep the power on/off for all IDUs.
- Do not connect the EasyCom (M1 M2) communication line to the PQ or D1D2 communication line.
- If the EasyCom (M1 M2) communication is available and is required in the system, you will need to enable the function on the master ODU. For details, refer to section 7.5.
- The communication wiring (M1 M2) must through the magnetic ring from the main board to the IDUs.
- When the system selects EasyCom (M1M2) communication, it is forbidden to connect build-out resistor to the end indoor unit, otherwise the communication will fail.

- EasyCom (M1 M2) communication wiring configuration – IDUs with separate power supply

$L1+La+Lx \leq 200m$ ,  $L11+Lb+Ly \leq 200m$ ,  $L21+Lc+L30 \leq 200mm$ . Communication wiring

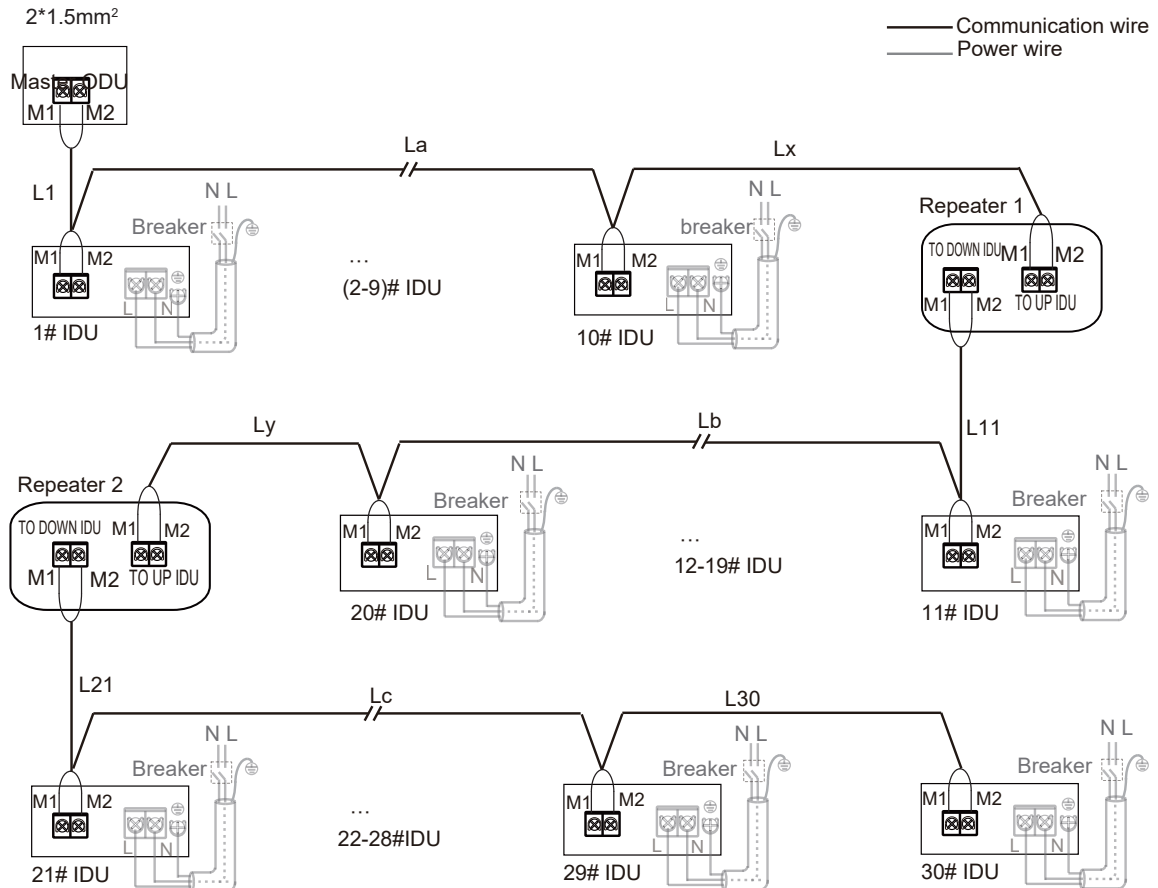

Figure 5.46

## ⚠ CAUTION

- If the total distance is less than or equal to 200m and the total number of IDUs is less than or equal to 10 sets, the valve is powered and controlled by the master ODU.
- If the total distance is longer than 200m or the total number of IDUs is more than 10 sets, a repeater is required to increase the bus voltage.
- The load capacity of the repeater is the same as that of the ODU, and it can load a bus length of 200m or 10 IDUs.
- A maximum of two repeaters can be installed in the same refrigerant system.
- The number of IDUs requiring power supply in the same refrigerant system is less than or equal to 30 sets.
- Keep the power on/off for both the repeater and the ODUs, or use an uninterruptible power supply with the repeater.
- For repeater installation, please refer to the repeater installation manual. Do not connect the upstream and downstream IDU ports of the repeater in reverse; otherwise, it will cause a communication failure.
- If the separate power supply function needs to be enabled in the system, it must be enabled on the master ODU. For details, refer to section 7.5.
- When the system selects EasyCom (M1M2) communication, it is forbidden to connect build-out resistor to the end indoor unit, otherwise the communication will fail.

- RS-485 (P Q E) communication wiring configuration  
 $L1+La+Ln \leq 1200m$ . Communication wiring  $3 \times 0.75mm^2$

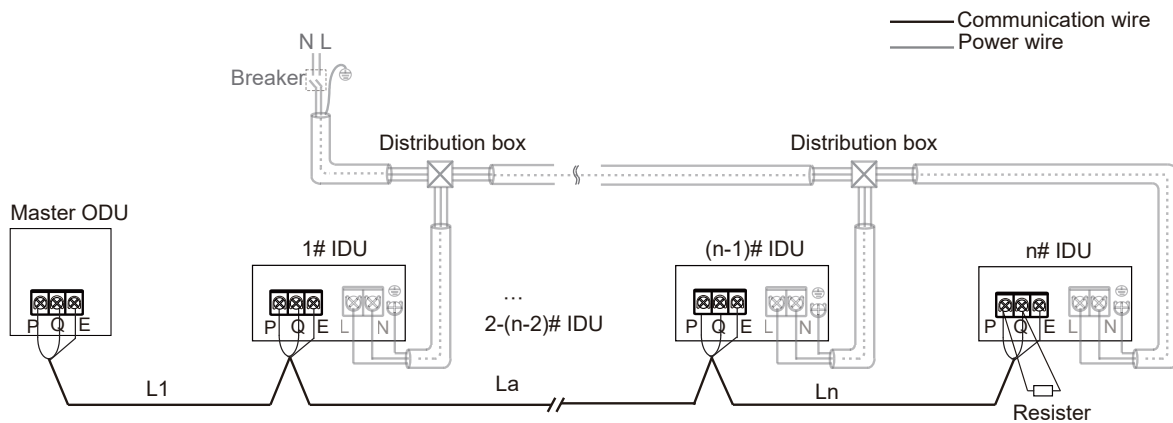

Figure 5.48

**CAUTION**

- After the last indoor unit, the communication wiring should not route back to the outdoor unit as this will form a closed loop.
- In the last indoor unit, connect a resistor of 120 ohms between the P and Q terminals.
- Do not bind the communication line, refrigerant piping and power cable together.
- When the power cable and communication line are laid in parallel, the distance between the two lines must be 5cm or more to prevent signal source interference.
- All IDUs in a system must be powered through a uniform power supply so that they can be powered on or off at the same time.
- All communication lines of the IDUs and ODUs must be connected in a series, use the shielded wire, and the shield layer must be grounded.
- The communication wiring (P, Q, E) must through the magnetic ring from the main board to the IDUs.

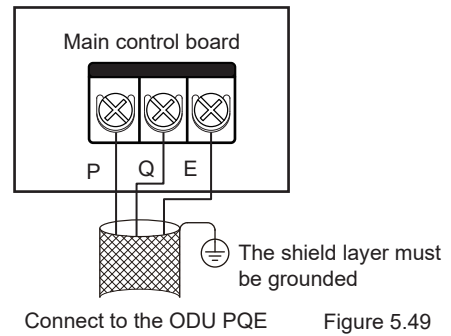

Figure 5.49



- XYE, H1H2 communication wiring

For V8 combinable series

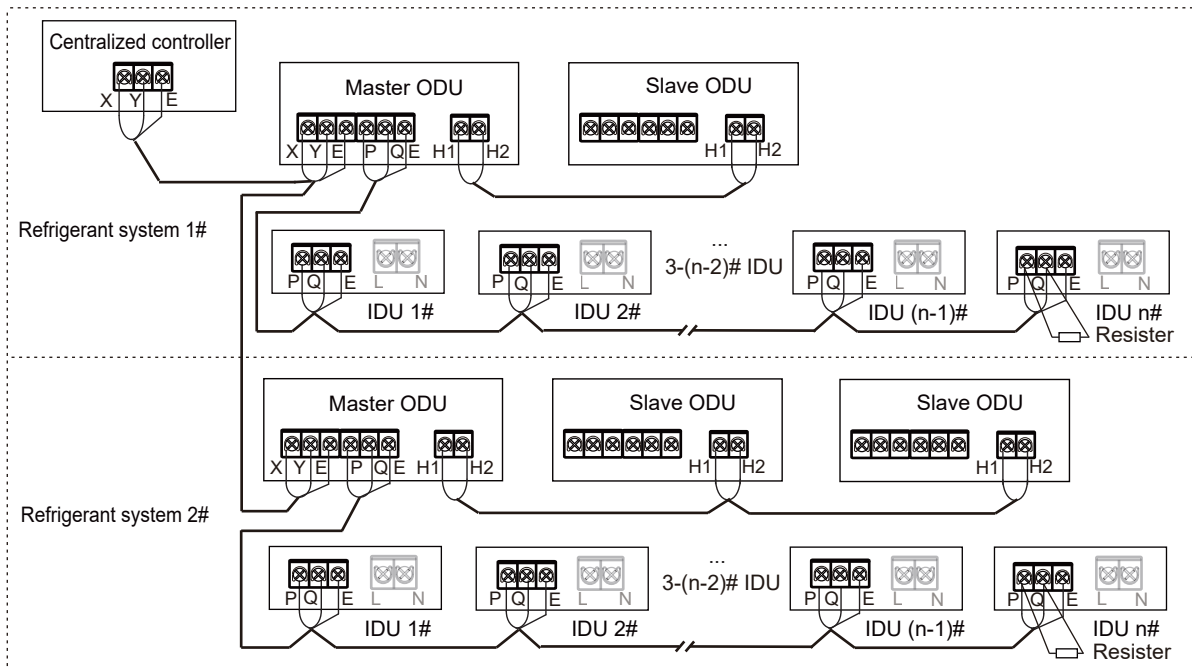

Figure 5.50

### ⚠ CAUTION

- The H1H2 communication lines of the outdoor unit should be connected in a chain starting from the master unit to the last slave unit. The XYE communication lines of the outdoor unit should be connected to the master unit.
- The cross-sectional area of each core of the communication wiring is not less than 0.75 mm<sup>2</sup>, and the length must not exceed 1200m.
- Connect the shielding nets at both ends of the shielded wire to the sheet metal "⊕" of the electronic control box.

## 6 CONFIGURATION

### 6.1 Overview

This chapter describes how the system configuration can be implemented once the installation is complete and other relevant information.

It contains the following information:

- Implement field settings
- Using the Check function

#### **i** INFORMATION

The installation personnel should read this chapter.

### 6.2 Digital Display and Button Settings

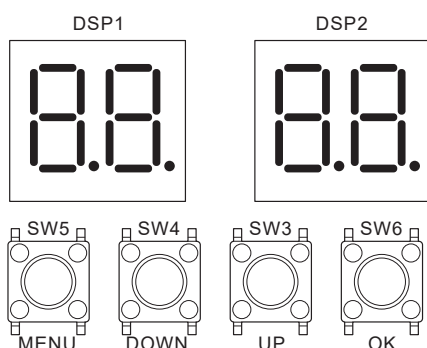

Figure 6.1

#### 6.2.1 Digital display output

Table 6.1

Outdoor unit state	Parameters displayed on DSP1	Parameters displayed on DSP2
Standby	Unit's address	The number of indoor units in communication with the outdoor units
Normal operation	Running speed of the compressor in rotations per second	
Error or protection	Placeholder and error or protection code	
In menu mode	Display menu mode code	
System check	Display system check code	

#### 6.2.2 Function of buttons SW3 to SW6

Table 6.2

Button	Function
SW3 (UP)	In menu mode: previous and next buttons for menu modes.
SW4 (DOWN)	Not in menu mode: previous and next buttons for system check information.
SW5 (MENU)	Enter / exit menu mode.
SW6 (OK)	Confirm to enter specified menu mode.

### 6.2.3 Menu mode

Only master unit has the full menu functions, slave units only have error code checking and cleaning functions.

1. Press and hold the SW5 "MENU" button for 5 seconds to enter menu mode, and the digital display displays "n1".
2. Press the SW3 / SW4 "UP / DOWN" button to select the first level menu "n1", "n2", "n3", "n4" or "nb".
3. Press the SW6 "OK" button to enter the specified first level menu, for example, enter "n4" mode.
4. Press the SW3 / SW4 "UP / DOWN" button to select the second level menu from "n41" to "n47".
5. Press the SW6 "OK" button to enter the specified second level menu, for example, enter "n43" mode.
6. Press the SW3 / SW4 "UP / DOWN" button to select the specified menu mode code.
7. Press the SW6 "OK" button to enter the specified menu mode.

#### **⚠** CAUTION

- Operate the switches and push buttons with an insulated stick (such as a closed ball-point pen) to avoid touching live parts.

Menu mode selection flowchart:

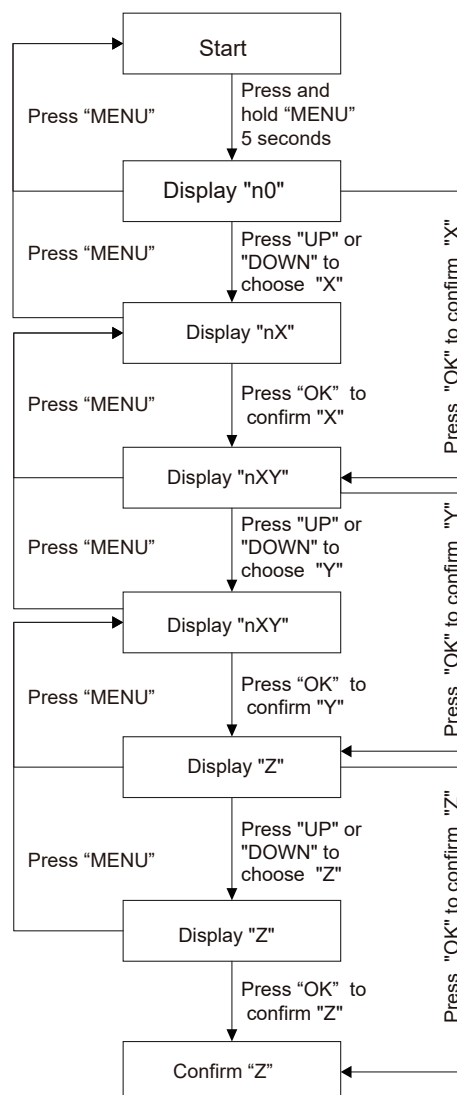

Table 6.3

First level menu	Second level menu	Specified menu mode	Description	Default	
n0	0	0	Query history error	-	
		1	Cleaning history error		
	1	0	Query Indoor unit's address		
		2	Query the address of Indoor unit in power-off condition		
		1	Driver's version (compressor and fan displayed in turn)		
4	-	Accumulated running time of compressor			
n1	0	-	Shield C26 and C28 error in 3 hours	-	
	1	0	Cooling Test		
		1	Heating Test		
		2	Test running		
		4	System refrigerant quantity detection		
	2	0	Refrigerant recovery to outdoor unit		
		1	Refrigerant recovery to indoor unit		
		2	Balance system refrigerant		
	3	0	Manual refrigerant charge		
		1	Auto refrigerant charge (Customized)		
4	-	Exit special mode			
5	-	Vacuum mode			
6	-	Set VIP indoor unit address			
n2	0	0	Automatic priority mode	√	
		1	Cooling priority mode	-	
		2	VIP indoor unit voting priority mode		
		3	In response to heating mode only		
		4	In response to cooling mode only		
		5	Heating priority mode		
		6	Change over		
		7	Voting priority mode		
		8	First on priority mode		
		9	Capability requirements priority mode		
	1	0	Non silent mode		√
		1	Silent mode 1	-	
		2	Silent mode 2		
		3	Silent mode 3		
		4	Silent mode 4		
		5	Silent mode 5		
		6	Silent mode 6		
		7	Silent mode 7		
		8	Silent mode 8		
		9	Silent mode 9		
	2	A	Silent mode 10		-
		b	Silent mode 11		
		C	Silent mode 12		
		d	Silent mode 13		
		E	Silent mode 14		
		0	0Pa static pressure	√	
		1	20Pa static pressure	-	
2	40Pa static pressure (Customized)				
3	60Pa static pressure (Customized)				
4	80Pa static pressure (Customized)				
5	100Pa static pressure (Customized)				
6	120Pa static pressure (Customized)				

First level menu	Second level menu	Specified menu mode	Description	Default
n2	3	40	Power limitation mode, Maximum current =MCA * setting value	-
		41		
		42		
		~		
		98		
		99		
		100		
	4	0	EMS function unavailable	-
		1	EMS function available	√
	5	0	Celsius unit	√
		1	Fahrenheit unit	-
	6	0	Anti-auto snow-blowing mode	√
		1	Auto snow-blowing mode 1	-
		2	Auto snow-blowing mode 2	-
	7	0	Auto dust-clean function unavailable	√
		1	Auto dust-clean function unavailable	-
	8	0	Dry contact closing effective	√
		1	Dry contact opening effective	-
	9	0	Mode Switching temperature: 10°C	√
		1	Mode Switching temperature: 16°C	-
		2	Mode Switching temperature: 21°C	-
n3	2	0	0m level difference between indoor unit and outdoor unit	√
		1	20m level difference between indoor unit and outdoor unit	-
		2	40m level difference between indoor unit and outdoor unit	
		3	60m level difference between indoor unit and outdoor unit	
		4	80m level difference between indoor unit and outdoor unit	
		5	100m level difference between indoor unit and outdoor unit	
		6	110m level difference between indoor unit and outdoor unit	
	E	0	PTC heating function unavailable	
1	PTC heating function available(Customized)	√		
n4	0	-	Set address of outdoor unit	-
	1	-	Set Network address of outdoor unit	0
	2	-	Set number of indoor units	1
	4	0	Auto addressing	-
		1	Clear address	-
	5	0	V8 communication protocol (RS-485 (P Q) communication)	√
		1	Non-V8 communication protocol (RS-485 (P Q E) communication)	-
		2	EasyCom (M1 M2) communication-IDUs uniform power supplied	-
3	EasyCom (M1 M2) communication-IDUs separate power supplied	-		
n5	0	0	Compressor and fan backup running unavailable	-
		1	Compressor and fan backup running available	√
	1	0	Sensors backup running unavailable	-
		1	Sensors backup running available (Manual)	√
		2	Sensors backup running available (Automatic)	-
	2	0	Backup operation time setting (1 day	-
		1	Backup operation time setting (2 days)	
		2	Backup operation time setting (3 days)	
		3	Backup operation time setting (4 days)	

First level menu	Second level menu	Specified menu mode	Description	Default
n5	2	4	Backup operation time setting(5 days)	-
		5	Backup operation time setting(6 days)	-
		6	Backup operation time setting(7 days)	√
n8	7	0	Low noise defrosting mode unavailable	√
		1	Low noise defrosting mode available	-
n9	1	0	Rotation function unavailable	-
		1	Compressor Rotation function available	-
		2	Outdoor unit Rotation function available	√
		3	Compressor + Outdoor unit Rotation function available	-
	5	-	Release central controller emergency stop	-
	7	0	Digital electricity meter	√
		1	Pulse electricity meter	-
nc			<b>Dry contact number:</b>	
	0	0	1 - CN28 Input 1 - Cooling only	-
		1	1 - CN28 Input 1 - Heating only	-
		2	1 - CN28 Input 1 - Outdoor unit test mode	-
		3	1 - CN28 Input 1 - Force stop	√
	1	0	2 - CN28 Input 2 - Cooling only	-
		1	2 - CN28 Input 2 - Heating only	-
		2	2 - CN28 Input 2 - Outdoor unit test mode	-
		3	2 - CN28 Input 2 - Force stop	√
	2	0	3 - CN93 Input 3 - Operation signal	-
		1	3 - CN93 Input 3 - Alarm signal	√
		2	3 - CN93 Input 3 - Compressor running signal	-
		3	3 - CN93 Input 3 - Defrosting signal	-
4		3 - CN93 Input 3 - Refrigerant leakage signal	-	

## 6.2.4 UP / DOWN system check button

Before pressing the UP or DOWN button, allow the system to operate steadily for more than an hour. Every time you press the UP or DOWN button, the parameters listed in the following table will be displayed in sequence

Table 6.4

DISP.	CONTENT	DESCRIPTION
--	"Standby (ODU address+ IDU quantity)/frequency/special status"	
0	ODU address	0-3, 255 represents invalid address
1	ODU capacity	Unit: HP
2	Quantity of ODUs	1-4 (1)
3	Quantity of IDUs	1-64 (1)
4	Total capacity of ODU system	Displayed on master ODU only (2)
5	Target frequency of this ODU	Displacement frequency (3)
6	Target frequency of ODU system	Displacement frequency=DISP. ×10
7	Actual frequency of compressor A	Actual frequency
8	Actual frequency of compressor B	Actual frequency
9	Operating mode	<b>【0】</b> OFF
		<b>【2】</b> Cooling
		<b>【3】</b> Heating
		<b>【5】</b> Main cooling
		<b>【6】</b> Main heating
10	Fan speed 1	Unit: RPM
11	Fan speed 2	Unit: RPM
12	T2 Average	Actual temperature=DISP. Unit: C
13	T2B Average	Actual temperature=DISP. Unit: C
14	T3	Actual temperature=DISP. Unit: C
15	T4	Actual temperature=DISP. Unit: C
16	T5	Actual temperature=DISP. Unit: C
17	T6A	Actual temperature=DISP. Unit: C
18	T6B	Actual temperature=DISP. Unit: C
19	T7C1	Actual temperature=DISP. Unit: C
20	T7C2	Actual temperature=DISP. Unit: C
21	T71	Actual temperature=DISP. Unit: C
22	T72	Actual temperature=DISP. Unit: C
23	T8	Actual temperature=DISP. Unit: C
24	Ntc_max	Actual temperature=DISP. Unit: C
25	T9 (Reserved)	Actual temperature=DISP. Unit: C
26	TL	Actual temperature=DISP. Unit: C
27	Discharge superheat degree	Actual temperature=DISP. Unit: C
28	Primary current	Actual current=DISP./10 Unit: A
29	Inverter compressor A current (A)	Actual current=DISP./10 Unit: A
30	Inverter compressor B current (A)	Actual current=DISP./10 Unit: A
31	EEVA position	Actual Value=DISP. *24
32	EEVB position	Actual Value=DISP. *24
33	EEVC position	Actual Value=DISP. *4
34	EEVD position	Actual Value=DISP. *4
35	High pressure of unit	Actual Pressure=DISP. /100 Unit: MPa
36	Low pressure of unit	Actual Pressure=DISP. /100 Unit: MPa
37	Quantity of online IDUs	Actual quantity
38	Quantity of running IDUs	Actual quantity

39	Heat exchanger status	<b>【0】</b> OFF		
		<b>【1】</b> C1: Condenser. Running		
		<b>【2】</b> D1: Condenser. Not running		
		<b>【3】</b> D2: Reserved		
		<b>【4】</b> E1: Evaporator. Running		
		<b>【5】</b> F1: Reserved		
40	Special mode	<b>【6】</b> F2: Evaporator. Not running		
		<b>【0】</b> Not in special mode		
		<b>【1】</b> Oil return		
		<b>【2】</b> Defrost		
		<b>【3】</b> Startup		
		<b>【4】</b> Stop		
41	Silent mode setting	<b>【5】</b> Quick check		
		<b>【6】</b> Self cleaning		
		0~14, 14 represents the most silent		
		<b>【0】</b> 0Pa		
		<b>【1】</b> 20Pa		
		<b>【2】</b> 40Pa		
42	Static pressure mode	<b>【3】</b> 60Pa		
		<b>【4】</b> 80Pa		
		<b>【5】</b> 100Pa		
		<b>【6】</b> 120Pa		
		43	Tes (Target evaporating temperature)	Actual temperature=DISP. Unit: °C
		44	Tcs (Target condensing temperature)	Actual temperature=DISP. Unit: °C
45	DC Voltage	Actual voltage Unit: V		
46	AC Voltage	Actual voltage Unit: V		
47	Quantity of cooling mode IDUs			
48	Quantity of heating mode IDUs			
49	Capacity of cooling mode IDUs			
50	Capacity of heating mode IDUs			
51	Refrigerant volume	<b>【0】</b> No result		
		<b>【1】</b> Critically insufficient		
		<b>【2】</b> Significantly insufficient		
		<b>【3】</b> Normal		
		<b>【4】</b> Slightly excessive		
51	Refrigerant volume	<b>【5】</b> Significantly excessive		
		52	Dirty blockage rate	0~10, 10 represents the worst
		53	Fan error	
		54	Software version	
		55	Last error code	
56	Reserved			
57	Reserved			
58	Reserved			

(1) Available for master unit.

(2) Only available for master unit, displayed on slave units has no sense.

(3) Need to convert to current compressor output volume, example: compressor output volume is 98, Target frequency = Actual frequency \* 98 / 60.

## 7 COMMISSIONING

### 7.1 Overview

After installation, and once the field settings have been defined, the installation personnel must verify the correctness of the operations. Follow the steps below to perform the test run.

This chapter describes how the test run can be carried out once the installation is complete, and other relevant information.

The test run usually includes the following stages:

1. Review the section titled "Checklist Before Test Run".
2. Implement the test run.
3. If necessary, correct the errors before the test run completes with exceptions.
4. Run the system

### 7.2 Things to Note During Test Run

#### ⚠ WARNING

During the test run, the outdoor unit operates at the same time as the MS boxes and indoor units connected to it. It is very dangerous to debug the MS boxes or indoor units during the test run.

Do not insert fingers, sticks, or other items into the air inlet or outlet. Do not remove the fan mesh cover. When the fan rotation is set at a high speed, it may cause bodily injury.

#### 💡 NOTE

Note that the required input power may be higher when this unit is run for the first time. This phenomenon is due to the compressor which needs to run for 50 hours before it can achieve a stable operating and power consumption state. Make sure the power supply is turned on 12 hours before operations so that the crankcase heater is properly energized. This is also to protect the compressor.

#### i INFORMATION

The test run can be carried out when the ambient temperature is within the required range as in Figure 7-1.

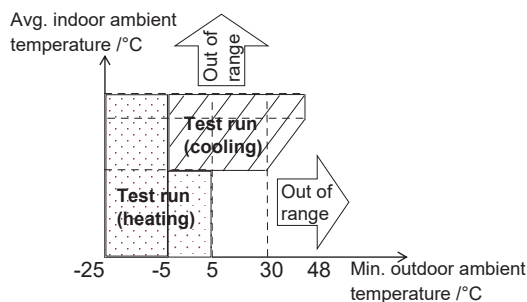

Figure 7.1

During the test run, the outdoor units, MS boxes and indoor units will start at the same time. Make sure all the preparations for the outdoor units, MS boxes and indoor units have been completed.

### 7.3 Checklist Before Test Run

Once this unit is installed, check the following items first. After all the following checks have been completed, you must shut down the unit. This is the only way to start the unit again.

<input type="checkbox"/>	<b>Installation</b> Check if the unit is installed correctly to prevent strange noises and vibrations when the unit starts.
<input type="checkbox"/>	<b>Field wiring</b> Based on the wiring schematic and the relevant regulations, make sure the field wiring is based on the instructions described in section 5.10 on connecting wires.
<input type="checkbox"/>	<b>Earth line</b> Make sure the earth line is connected correctly, and the grounding terminal is tight.
<input type="checkbox"/>	<b>Insulation test of the main circuit</b> Use the megameter of 500V, apply a voltage of 500V DC between the power terminal and the earth terminal. Check that the insulation resistance is above 2 MΩ. Do not use the megameter on the transmission line.
<input type="checkbox"/>	<b>Fuses, circuit breakers, or protection devices</b> Check that the fuses, circuit breakers, or locally installed protection devices comply with the size and type specified in section 4.4.2 on the requirements for safety devices. Make sure you use fuses and protection devices.
<input type="checkbox"/>	<b>Internal wiring</b> Visually inspect if the connections between the electrical component box and the interior of the unit is loose, or if the electrical components are damaged.
<input type="checkbox"/>	<b>Piping dimensions and insulation</b> Make sure the installation piping dimensions are correct, and that insulation work can be carried out normally.
<input type="checkbox"/>	<b>Stop valve</b> Make sure the stop valve is open on both the liquid, low pressure and high pressure gas sides.
<input type="checkbox"/>	<b>Equipment damage</b> Check for damaged components and extruded piping inside the unit.
<input type="checkbox"/>	<b>Refrigerant leak</b> Check for refrigerant leaks inside the unit. If there is a refrigerant leak, try to repair the leak. If the repair is not successful, please call the local agent. Do not come into contact with the refrigerant leaking from the refrigerant piping connections. It may cause frostbite.
<input type="checkbox"/>	<b>Oil leak</b> Check if there is oil leaking from the compressor. If there is an oil leak, try to repair the leak. If the repair is not successful, please call the local agent.
<input type="checkbox"/>	<b>Air inlet/outlet</b> Check for paper, cardboard or any other material that may obstruct the air inlet and outlet of the equipment.
<input type="checkbox"/>	<b>Add additional refrigerant</b> The amount of refrigerant to be added to this unit should be marked on the "Confirmation Table" which is located on the front cover of the electrical control box.
<input type="checkbox"/>	<b>Installation date and field settings</b> Make sure the installation date is recorded on the label of the electric control box cover, and the field settings are recorded as well.



## 7.4 About Test Run

The following procedures describe the test run of the whole system. This operation checks and determines the following items:

- Check if there is a wiring error (with the communication check of the indoor unit).
- Check if the stop valve is open.
- Determine the length of the pipe.

### **i** INFORMATION

- Before you start the compressor, it may take 10 minutes to achieve a uniform cooling state.
- During the test run, the sound of the cooling mode in operation or the solenoid valve may become louder, and there may be changes in the displayed indicators. This is not a malfunction.

## 7.5 Test Run Implementation

1. Make sure all the settings you need to configure are completed. See section 6.2 on the implementation of the field settings.
2. Turn on the power supply of the outdoor unit and the indoor units.

### **i** INFORMATION

Make sure the power supply is turned on 12 hours before operations so that the crankcase heater is properly energized. This is also to protect the compressor.

**Specific procedures for the test run are as follows:**

#### **Step 1: Power on**

Cover the lower panel of the ODU, and power on all IDUs and ODUs.

#### **Step 2: Enter commissioning mode**

When the ODU is first powered on, it displays "-.-.-.-", which means the unit is not commissioned.

Long press the "DOWN" and "UP" buttons simultaneously for 5s on the master ODU to enter commissioning mode.

#### **Step 3: Set the number of IDUs in a system**

The digital display of the master ODU displays "01 01", where 1st and 2nd digits always on, 3rd and 4th digits flashing. The 3rd and 4th digits represent the number of IDUs, the initial value is 1, short press the "DOWN" or "UP" button to change the number.

Once the number of IDUs has been set, short press the "OK" button to confirm and automatically proceed to the next step.

#### **Step 4: Select the system communication protocol**

Enter the communication protocol setting interface, the digital display of master ODU displays "02 0", where the 1st and 2nd digits always on, the 3rd digit off, the 4th digit flashing. The 4th digit of the digital display represents the communication protocol type, the initial value is 0. Short press the "DOWN" or "UP" button to change the communication protocol.

If the system is all V8 IDUs, and the IDUs and ODUs are connected by PQ communication, please select V8 protocol RS-485 (P Q) communication, and set the 4th digit of the master ODU digital display to 0; ODU factory default V8 protocol RS-485 (P Q) communication.

If the system has a non-V8 IDUs, and the IDUs and ODUs are connected by PQE communication, please select the non-V8 protocol RS-485 (P Q E) communication and set the 4th digit of the master ODU digital display to 1.

If the system is all V8 IDUs, the IDUS and ODUs are connected by M1M2 communication, and all IDUs are powered uniformly, please select the EasyCom (M1M2) communication + indoor unit uniform power supply, and set the 4th digit of the master ODU digital display to 2.

If the system is all V8 IDUs, the IDUS and ODUs are connected by M1M2 communication, and there is separate power supply for IDUS, please select the EasyCom (M1M2) communication + indoor unit separate power supply, and set the 4th digit of the master ODU digital display to 3.

Once the communication protocol has been set, short press the "OK" button to confirm and automatically proceed to the next step.

#### **Step 5: IDUs and ODUs address setting**

Enter the auto addressing function, the digital display of master ODU flashes "AU Ad" and "X YZ" in rotation. "AU Ad" means the auto addressing is in progress, "X" represents the address of the ODU, "YZ" represents the number of detected IDUs; the auto addressing takes about 5-7 minutes, and automatically proceed to the next step after completion.

#### **Step 6: System initialization**

Entering system initialization, the digital display of master ODU flashes "INIt" and "X YZ" in rotation. "INIt" means initialization is in progress, "X" represents the address of the ODU, "YZ" represents the number of detected IDUs; the system initialization takes about 3-5 minutes, and automatically proceed to the next step after completion.

#### **Step 7: End**

After system initialization, if there is no fault in the system, all ODUs will enter standby mode and the digital display will display "X YZ" ("X" represents the address of the ODUs, "YZ" represents the number of detected IDUs), and the unit can be turned on normally.

After system initialization, if the ODU detects a fault, the digital display of master ODU will display "X YZ" ("X" represents the address of the ODU, "YZ" represents the number of detected IDUs) and the error code in rotation. Please refer to the Error Code Table for troubleshooting, and the unit can be turned on normally after the fault is cleared.

commissioning flow chart

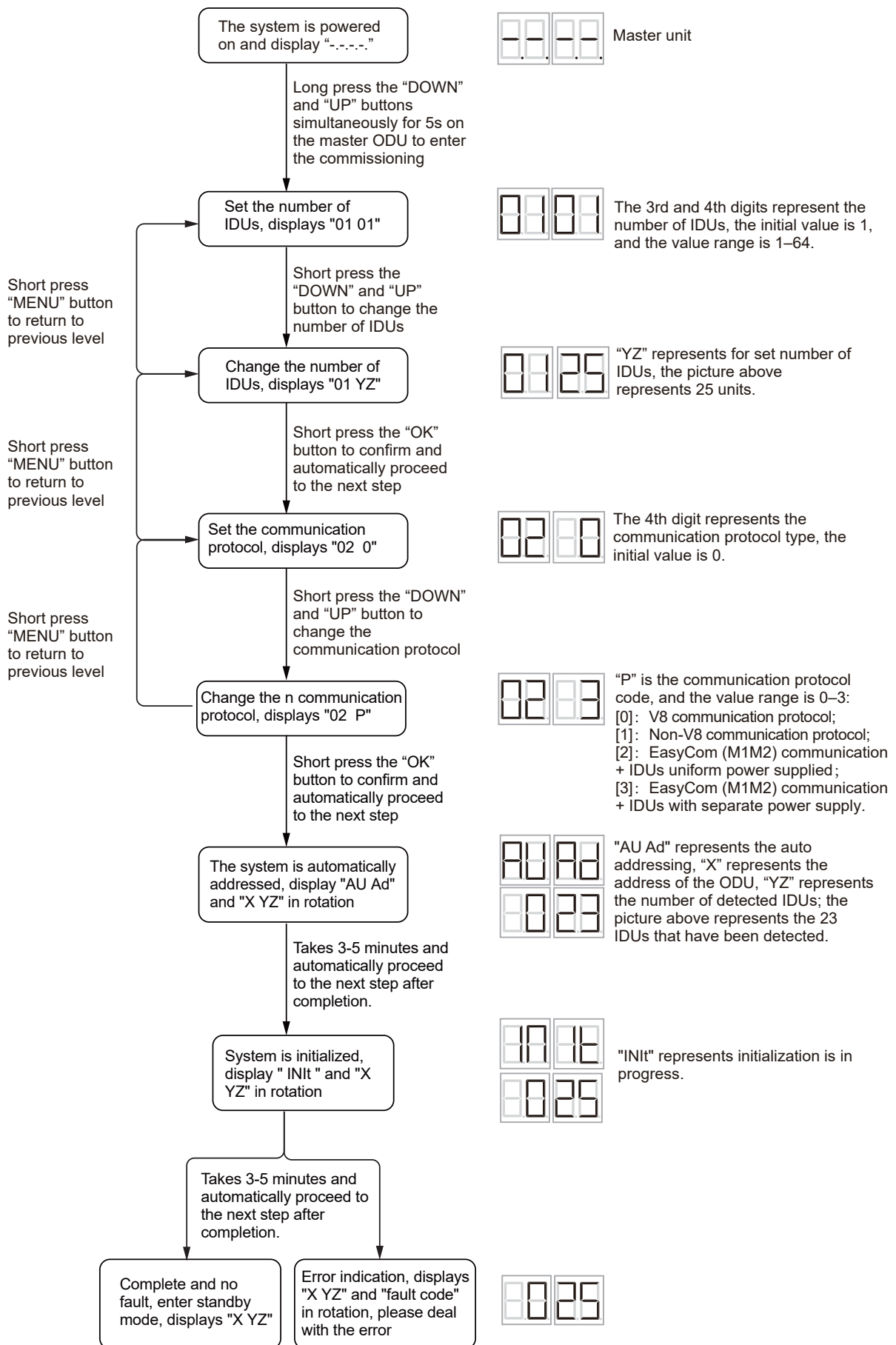

## 7.6 Rectifications after Test Run is Completed with Exceptions

The test run is considered complete when there is no error code on the user interface or the outdoor unit display. When an error code is displayed, rectify the operation based on the description in the error code table. Try to conduct the test run again to check that the exception has been corrected.

### **i** INFORMATION

Refer to the installation manual of the indoor unit for details on other error codes related to the indoor unit.

## 7.7 Operating This Unit

Once the installation of this unit is completed, and the test run of the outdoor and indoor units is done, you can start to run the system.

The indoor unit user interface should be connected to facilitate the operations of the indoor unit. Please refer to the installation manual of the indoor unit for more details.

## 8 MAINTENANCE AND REPAIR

### **i** INFORMATION

Arrange for the installation personnel or service agent to carry out maintenance once every year.

### 8.1 Overview

This chapter contains the following information:

- Take electrical hazards preventive measures during system maintenance and repair.
- Recovery operation for refrigerant.

### 8.2 Safety Precautions for Maintenance

#### **NOTE**

Before you carry out any maintenance or repair work, touch the metal parts of the unit to dissipate static electricity and protect the PCB.

#### 8.2.1 Prevent electrical hazards

When maintaining and repairing the inverter:

1. Do not open the cover of the electrical component box within 5 minutes after the power is switched off.
2. Verify that the power supply is switched off before you use the measuring instrument to measure the voltage between the main capacitor and the main terminal to ensure that the capacitor voltage in the main circuit is less than 36 VDC. The position of the main terminal has been shown in the Wiring nameplate (The port of CN38 on the compressor drive board).
3. Before you come in any contact with the circuit board or components (including the terminals), make sure that static electricity in your own body is eliminated. You can touch the sheet metal of the outdoor unit to achieve this. If conditions permit, please wear an anti-static bracelet.
4. During maintenance, pull out the plug connecting to the power cord of the fan to prevent the fan from rotating when it is windy outside. Strong winds will cause the fan to rotate and generate electricity which can charge the capacitor or terminals, leading to an electric shock. At the same time, do take note of any mechanical damage. The blades of a fan rotating at high speed are very dangerous and cannot be operated by one person alone.

5. Once the maintenance is completed, remember to reconnect the plug to the terminal; otherwise, a fault will be reported for the main control board.

6. When the unit is power on, the fan of the unit with auto snow-blowing function will run periodically, so make sure the power supply is off before touching the unit.

Please refer to the wiring schematic on the back of the box cover of the electrical component box for the relevant details.

## 9 TECHNICAL DATA

### 9.1 Dimensions

#### **NOTE**

- Product dimensions may vary slightly due to different panels and the tolerance is  $\pm 30\text{mm}$ . The actual product shall prevail.
- Product pictures in this manual are for reference only.

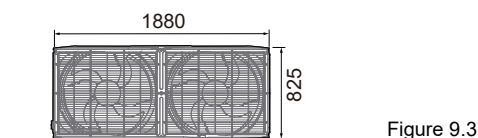
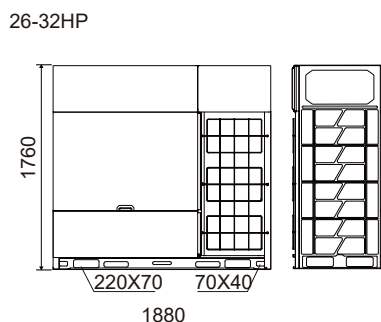
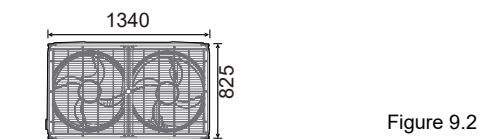
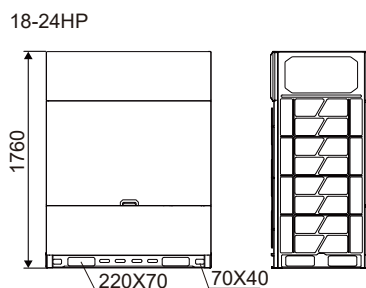
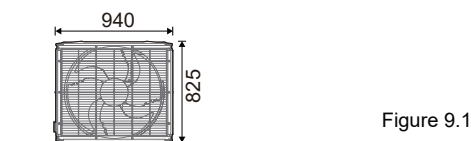
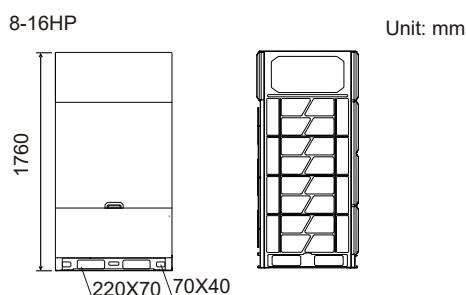

## 9.2 Component Layout and Refrigerant Circuits

8-16 HP

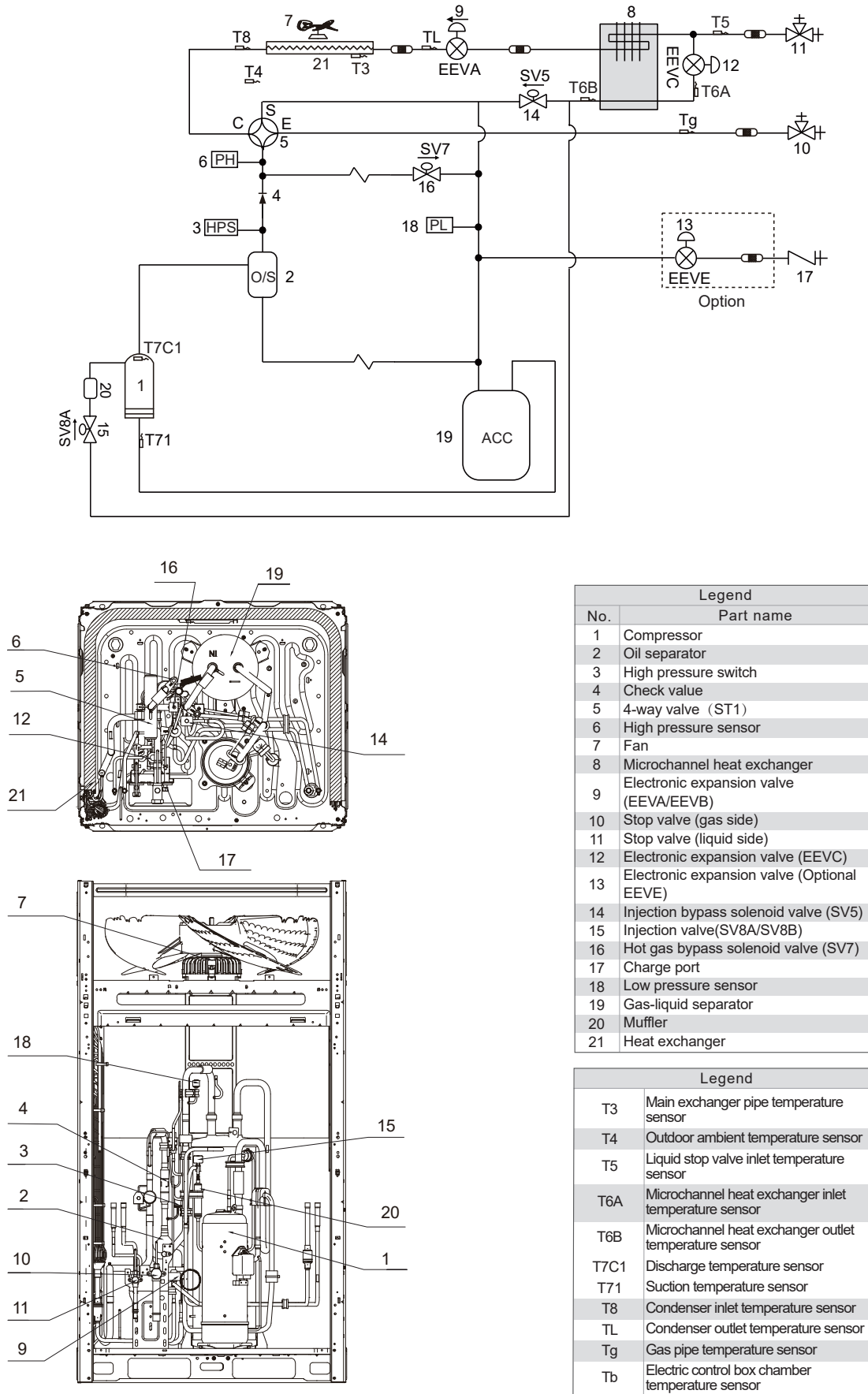

Figure 9.4

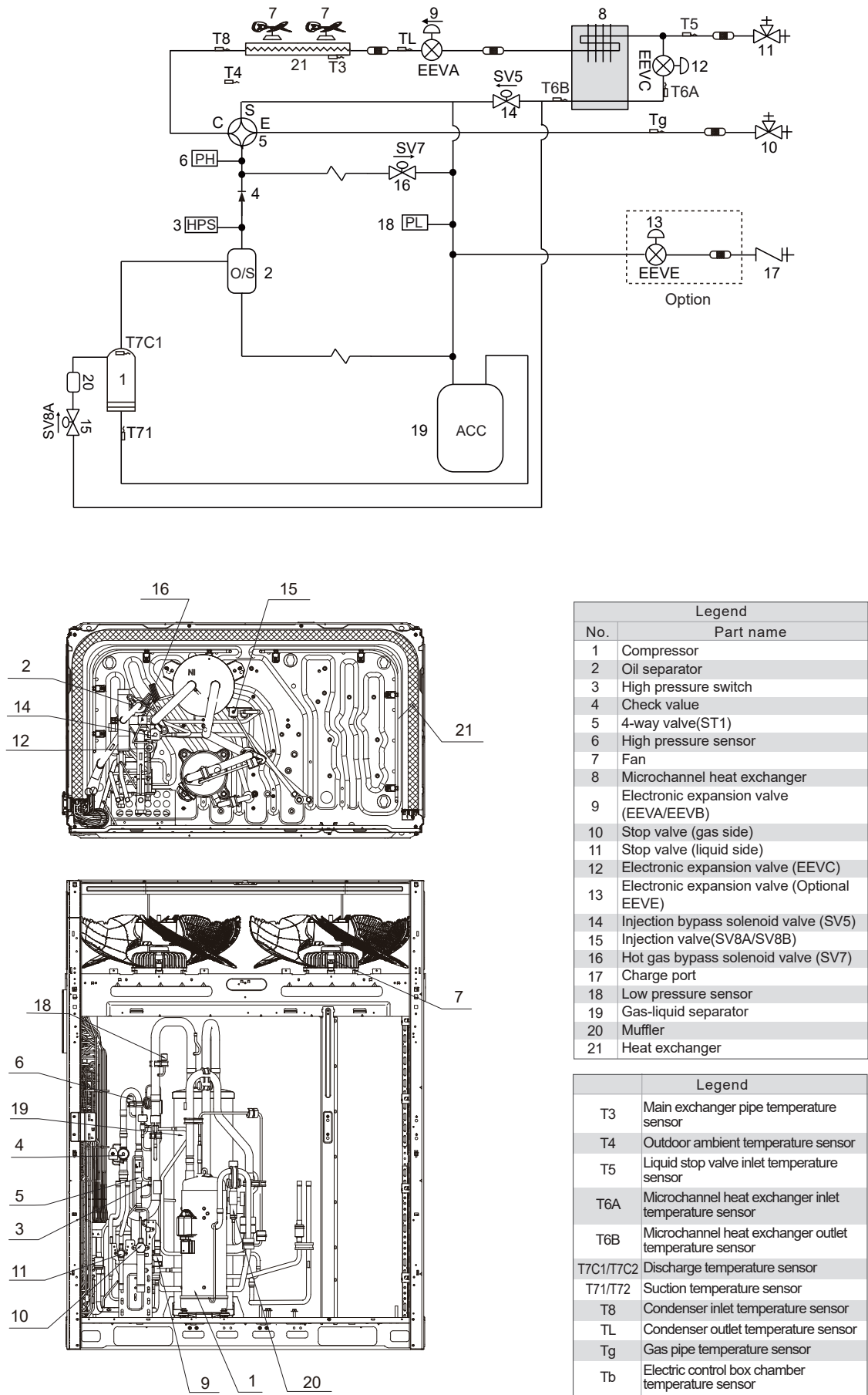
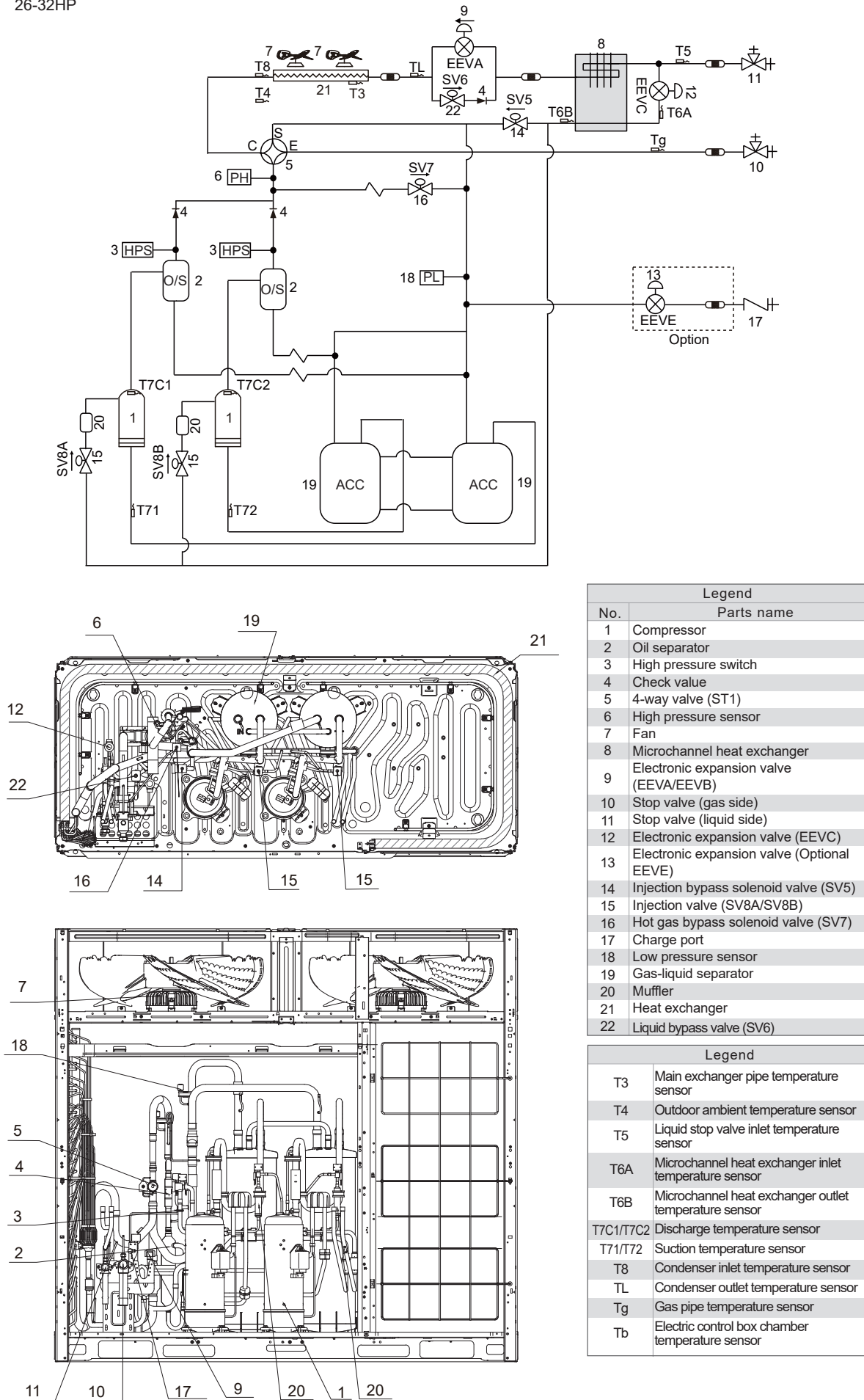

Figure 9.5



Legend	
No.	Parts name
1	Compressor
2	Oil separator
3	High pressure switch
4	Check valve
5	4-way valve (ST1)
6	High pressure sensor
7	Fan
8	Microchannel heat exchanger
9	Electronic expansion valve (EEVA/EEVB)
10	Stop valve (gas side)
11	Stop valve (liquid side)
12	Electronic expansion valve (EEVC)
13	Electronic expansion valve (Optional EEVE)
14	Injection bypass solenoid valve (SV5)
15	Injection valve (SV8A/SV8B)
16	Hot gas bypass solenoid valve (SV7)
17	Charge port
18	Low pressure sensor
19	Gas-liquid separator
20	Muffler
21	Heat exchanger
22	Liquid bypass valve (SV6)

Legend	
T3	Main exchanger pipe temperature sensor
T4	Outdoor ambient temperature sensor
T5	Liquid stop valve inlet temperature sensor
T6A	Microchannel heat exchanger inlet temperature sensor
T6B	Microchannel heat exchanger outlet temperature sensor
T7C1/T7C2	Discharge temperature sensor
T71/T72	Suction temperature sensor
T8	Condenser inlet temperature sensor
TL	Condenser outlet temperature sensor
Tg	Gas pipe temperature sensor
Tb	Electric control box chamber temperature sensor

Figure 9.6

### 9.3 Outdoor Unit Ducting

The following principles shall be followed when installing the air guide device:

- Before installing outdoor unit ducting, be sure to remove the unit's steel mesh cover; otherwise, airflow will be adversely affected.
- Each duct should contain no more than one bend.
- Vibration isolation should be added to the connection between the unit and the ducting to avoid vibration/noise.

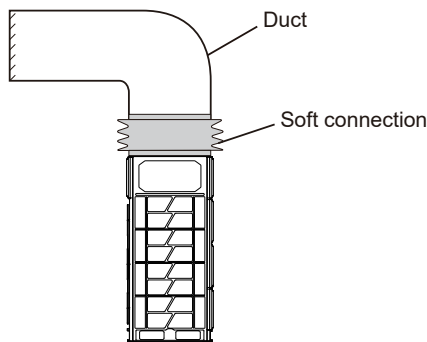
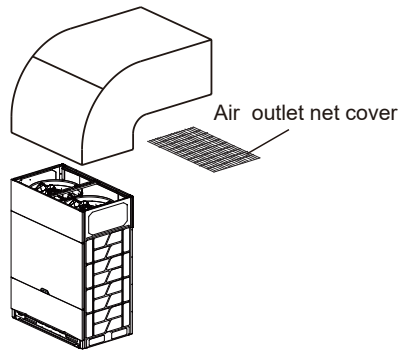

Figure 9.7

- The addition of louvers will affect the air output of the unit, so the use of louvers is not recommended. If you want to use a louver, please keep the shutter angle below 15 ° and ensure that the effective opening rate of the shutter is more than 90%.
- If more than one outdoor unit needs ducting, each outdoor unit should have independent ducting. A single ducting cannot be shared by multiple outdoor units.
- According to the actual static pressure of the outdoor unit ducting, select an appropriate static pressure mode. Refer to section 6.2.

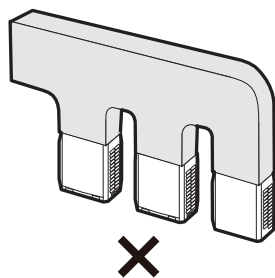

Figure 9.8

Option A: Transverse ducting

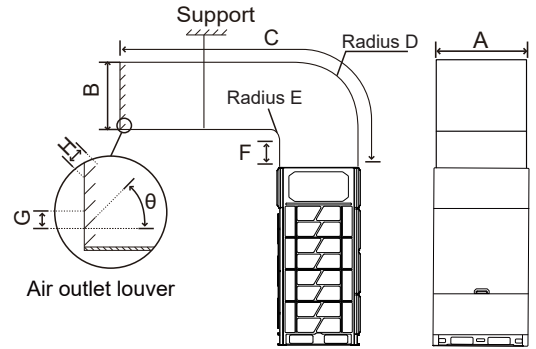

Figure 9.10

Table 9.1

Unit: mm

HP	8-16HP	18-24HP	26-32HP
A	800	1290	1680
B	770 ≤ B ≤ 800	770 ≤ B ≤ 800	770 ≤ B ≤ 800
C	≤ 3000	≤ 3000	≤ 3000
D	E + 770	E + 770	E + 770
E	≥ 300	≥ 300	≥ 300
F	≥ 250	≥ 250	≥ 250
θ	≤ 15°	≤ 15°	≤ 15°
G	≥ 100	≥ 100	≥ 100
H	≤ 90	≤ 90	≤ 90

Option B: Longitudinal ducting

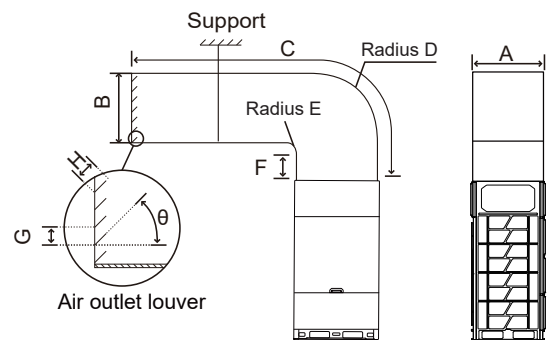

Figure 9.11

Table 9.2

Unit: mm

HP	8-16HP	18-24HP	26-32HP
A	770	770	770
B	820	1310	1700
C	≤ 3000	≤ 3000	≤ 3000
D	E + 800	E + 1290	E + 1680
E	≥ 300	≥ 300	≥ 300
F	≥ 250	≥ 250	≥ 250
θ	≤ 15°	≤ 15°	≤ 15°
G	≥ 100	≥ 100	≥ 100
H	≤ 90	≤ 90	≤ 90

## 9.4 Fan Performance

8-12HP unit fan performance

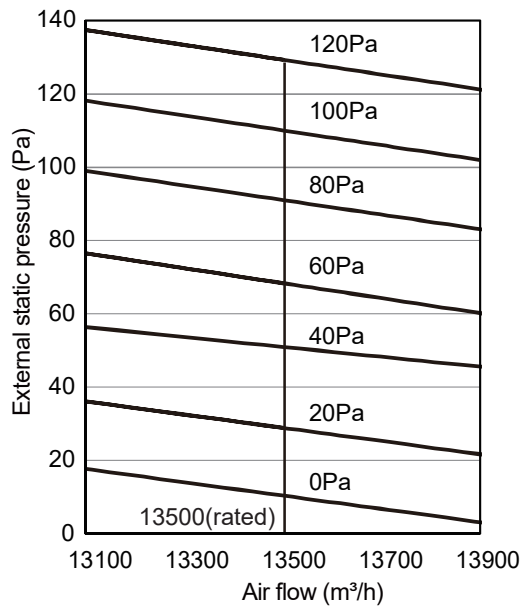

18-24HP unit fan performance

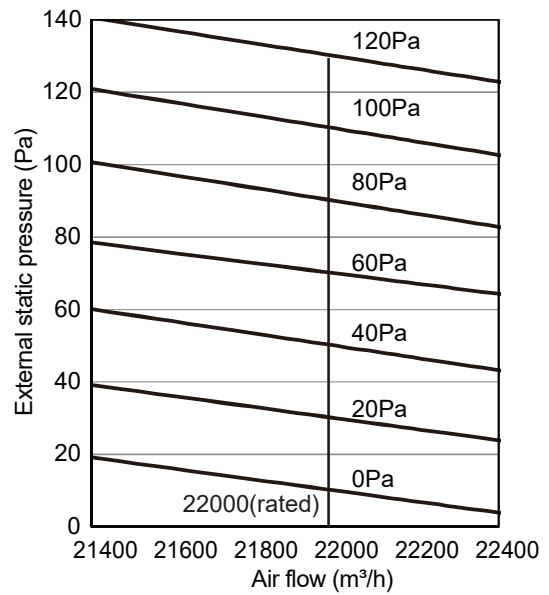

14-16HP unit fan performance

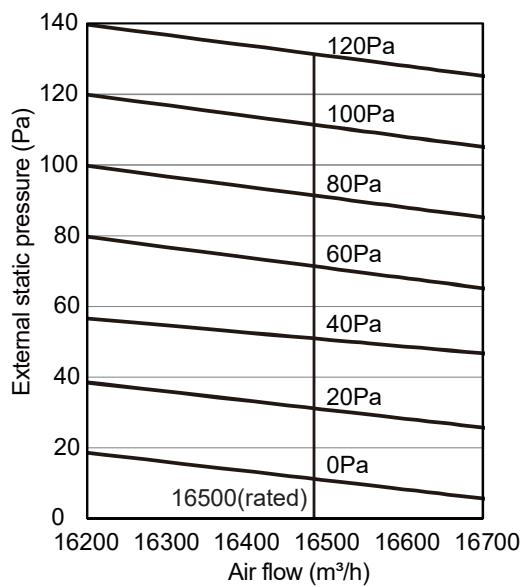

26-32HP unit fan performance

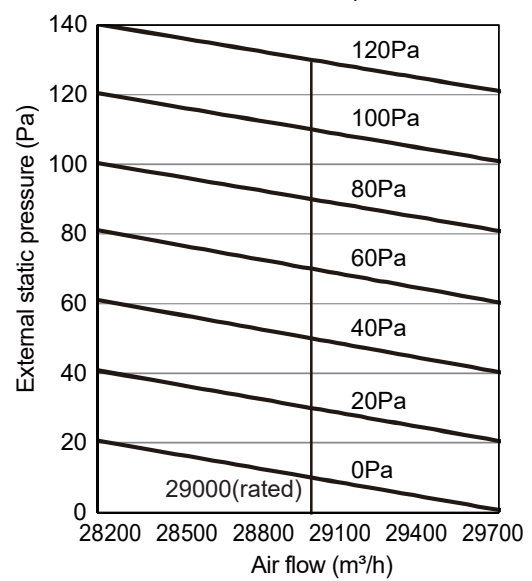

### NOTE

Static pressure exceeds 20Pa needs to be customized.



FOR 30 YEARS WE HAVE BEEN OFFERING  
SOLUTIONS FOR SUSTAINABLE  
COMFORT AND THE WELL-BEING OF  
PEOPLE AND THE ENVIRONMENT

[www.clivet.com](http://www.clivet.com)

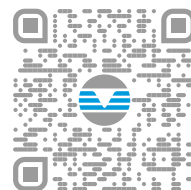

sales and service



**CLIVET SPA**

Via Camp Lonc 25, Z.I. Villapaiera  
32032 Feltre (BL) - Italy  
Tel. +39 0439 3131 - Fax +39 0439 313300  
[info@clivet.it](mailto:info@clivet.it)

**MideaGroup**  
*humanizing technology*