



WiSAT-YEE1 FC

45.4 - 90.4

Manual
for installation
use and maintenance



Dear Customer,

We congratulate you on choosing these product

Clivet has been working for years to offer systems able to assure the maximum comfort for a long time with highly-reliable, efficient, high-quality and safe solutions.

The target of the company is to offer advanced systems, that assure the best comfort and reduce energy consumption as well as the installation and maintenance costs for the entire life-cycle of the system.

With this manual, we want to give you information that are useful for all phases: from reception, installation and use to disposal - so that such an advanced system can provide the best performances during installation and use.

Best regards and have a good read.

CLIVET Spa

The data contained in this manual is not binding and may be changed by the manufacturer without prior notice. Reproduction, even is part, is FORBIDDEN

© Copyright - CLIVET S.p.A. - Feltre (BL) - Italy

Summary

1.	Safety considerations	7
1.1	Safety	7
1.2	Manual	7
1.3	Risk situations	7
1.4	Intended use	7
1.5	Installation	7
1.6	Maintenance	7
1.7	Modification	7
1.8	Breakdown/Malfuction	7
1.9	User training	7
1.10	Data update	7
1.11	Original instructions	7
2.	Indications for the User	8
2.1	Breakdown/Malfuction	8
2.2	The installer must train the user, particularly on:	8
2.3	Unit indentification	8
2.4	Serial number	8
3.	Information on refrigerant gas	9
4.	Before installation	10
4.1	Reception	10
4.2	Storage	10
4.3	Packaging removing	10
4.4	Handling	10
5.	Selecting the installation site	11
5.1	General	11
5.2	Maximum altitude of the installation	11
5.3	Electromagnetic compatibility (EMC)	11
5.4	Functional spaces	11
5.5	Positioning	11
5.6	Air flow-rate on the coils	11
5.7	Saftey valve gas side	12
6.	Water connections	13
6.1	Hydraulic system	13
6.2	Water quality	13
6.3	Cleanliness	13
6.4	New systems	13
6.5	Existing systems	13
6.6	Risk of freezing	14
6.7	Anti-freeze solution	14
6.8	Water flow-rate	14
6.9	Minimum system water content	14
6.10	Flow Switch	14
6.11	Water filter	15
6.12	Non-return valve	15
6.13	Operation sequence	15
6.14	Hydronic units and connection diagrams recommended	15
6.15	Standard unit	16
6.16	Unit + pump	16

6.17	Unit + water tank.....	17
6.18	Unit in modular configuration.....	17
7.	Electrical connections.....	18
7.1	Electrical data.....	18
7.2	Connections.....	18
7.3	Power supply network requirements.....	18
7.4	Signals / data lines.....	18
7.5	Power line inlet.....	19
7.6	Controller wiring sections.....	19
7.7	Remote ON-OFF.....	19
7.8	Connections performed by Customer.....	20
7.9	Remote control of the unit.....	21
7.10	Remote control of the unit.....	21
7.11	Position of REMAU board.....	21
7.12	Connections performed by customer - unit with REMAU.....	22
7.13	TW probe.....	23
7.14	Taf1 probe.....	23
7.15	T5 probe.....	23
7.16	Alarm signal.....	23
7.17	Compressor running signal.....	23
7.18	External pump control.....	23
7.19	Use remote keypad control.....	24
7.21	Double keypad.....	24
8.	Start-up.....	25
8.1	Start-up sequence.....	26
8.2	Start-up sequence.....	27
8.3	Refrigeration circuit.....	28
8.4	Electric Circuit.....	28
8.5	Options.....	28
8.6	Start-up report.....	28
8.7	2014/68/UE PED directive.....	28
8.8	Free cooling.....	29
9.	Control.....	30
9.1	Panel.....	30
9.2	Buttons.....	30
9.3	Lock/Unlock keys.....	30
9.4	Switch-On/Off.....	30
9.5	Unit in modular configuration.....	30
9.6	Display.....	31
9.7	Set Date, Time, Language.....	32
9.8	Set MODE and TEMPERATURE.....	32
9.9	Double setpoint.....	32
9.10	Snow protection function.....	32
9.11	Silent mode.....	33
9.12	Querying variables.....	33
9.13	Timer.....	34
9.15	Alarms.....	37
10.	R32 gas safety warnings.....	39
10.1	Area checks.....	39
10.2	Work procedures.....	39
10.3	General work area.....	39

10.4	Check the presence of refrigerant.....	39
10.5	Presence of the fire extinguisher	39
10.6	No ignition source	39
10.7	Ventilated area	39
10.8	Cooling equipment checks	39
10.9	Electrical device checks	39
10.10	Repairing sealed components	39
10.11	Reparation of intrinsically safe components	40
10.12	Wires	40
10.13	Leak detection methods	40
10.14	Removal and evacuation	40
10.15	Charging operations	40
10.16	Dismantling.....	41
10.17	Labelling.....	41
10.18	Recovery	41
10.19	Transport, mark and storage	41
11.	Maintenance.....	42
11.1	Safety	42
11.2	General.....	42
11.3	Inspections frequency	42
11.4	Unit booklet.....	42
11.5	Standby mode	42
11.7	System drain	44
11.8	Compressor crankcase heater.....	44
11.9	Water side exchanger.....	44
11.10	Water filter	44
11.11	Flow Switch	44
11.12	Circulation pumps.....	44
11.13	Insulations.....	44
11.14	Pressure relief valve	44
11.15	Structure.....	44
11.16	Air side exchanger.....	44
11.17	Electric fans.....	45
11.18	Refrigerant leak detector.....	45
12.	Anti-vibration mounts	46
12.1	Anti-vibration mount support.....	46
12.2	Anti-seismic anti-vibration mounts.....	48
13.	Decommissioning	50
13.1	Disconnection.....	50
13.2	WEEE INFORMATION	50
14.	Residual risks	51
14.1	General.....	51
14.2	Handling.....	51
14.3	Installation	51
14.4	General risks	51
14.5	Electric parts	51
14.6	Moving parts	52
14.7	Refrigerant.....	52
14.8	Hydraulic parts	52
15.	Unit in modular configuration.....	53
15.1	Control logic.....	53

15.2	Tw control probe.....	53
15.3	Electrical connections	53
15.4	System with reversed return connection	53
15.7	Remote ON-OFF	55
15.8	Start-up.....	55
15.9	Alarms.....	55
16.	Modbus	56
16.1	Communication specifications: RS - 485.....	56
17.	Technical information	65

1. Safety considerations

1.1 Safety

Operate in compliance with safety regulations in force.

To carry out the operations use protection devices:

gloves, goggles, helmet, headphones, protective knee pads.

All operations must be carried out by personnel trained on possible risks of a general nature, electrical and deriving from operating with equipment under pressure.

Only qualified personnel can operate on the unit, as required by the regulation in force.

1.2 Manual

The manual provides correct unit installation, use and maintenance.

It is advisable to read it carefully so you will save time during operations.

Follow the written indications so you will not cause damages to things and injuries people.

The manual must be delivered to the User.

1.3 Risk situations

The unit has been designed and created to prevent injuries to people.

During designing it is not possible to plane and operate on all risk situation.

Read carefully "Residual risk" section where all situation which may cause damages to things and injuries to people are reported.

Installation, starting, maintenance and repair required specific knowledge; if they are carried out by inexperienced personnel, they may cause damages to things and injuries people.

1.4 Intended use

Use the unit only:

- for cooling/heating water or a water and glycol mix
- keep to the limits foreseen in the technical schedule and in this manual

The manufacturer accepts no responsibility if the equipment is used for any purpose other than the intended use.

1.5 Installation

► Outdoor installation

The positioning, hydraulic system, refrigerating, electrics and the ducting of the air must be determined by the system designer in accordance with local regulations in force.

Follow local safety regulations.

Verify that the electrical line characteristics are in compliance with data quotes on the unit serial number label.

1.6 Maintenance

Plan periodic inspection and maintenance in order to avoid or reduce repairing costs.

Turn the unit off before any operation.

1.7 Modification

All unit modifications will end the warranty coverage and the manufacturer responsibility.

1.8 Breakdown/Malfuction

Disable the unit immediately in case of breakdown or malfunction.

Contact a certified service agent.

1.9 User training

The installer has to train the user on:

- Start-up/shutdown
- Set points change
- Standby mode
- Maintenance
- What to do / what not to do in case of breakdown

1.10 Data update

Continual product improvements may imply manual data changes.

Visit manufacturer web site for updated data.

1.11 Original instructions

The original instructions are written in Italian.

All other languages are translations of the original instructions.

2. Indications for the User

Keep this manual with the wiring diagram in an accessible place for the operator.

Note the unit data label so you can provide them to the assistance centre in case of intervention (see “Unit identification” section).

Provide a unit notebook that allows any interventions carried out on the unit to be noted and tracked making it easier to suitably note the various interventions and aids the search for any breakdowns.

2.1 Breakdown/Malfuction

Disable the unit immediately in case of breakdown or malfunction.

Contact a certified service agent.

Use original spares parts only.

Using the unit in case of breakdown or malfunction:

- voids the warranty
- it may compromise the safety of the unit
- may increase time and repair costs

2.2 The installer must train the user, particularly on:

- Start-up/shutdown
- Set points change
- Standby mode
- Maintenance
- What to do / what not to do in case of breakdown

2.3 Unit identification

The serial number label is positioned on the unit and allows to identify all the unit features.

The matriculation plate shows the indications foreseen by the standards, in particular:

- unit type
- serial number (12 characters)
- year of manufacture
- wiring diagram number
- electrical data
- type of refrigerant
- refrigerant charge
- manufacturer logo and address

The matriculation plate must never be removed.

2.4 Serial number

It identifies uniquely each unit.

Must be quoted when ordering spare parts.

2.5 Assistance request

Note data from the serial number label and write them in the chart on side, so you will find them easily when needed.

Range
Size
Serial number
Year of production
Wiring diagram number

3. Information on refrigerant gas

WARNING

- ▶ This product contains fluorinated greenhouse gases covered by the Kyoto protocol.
- ▶ Do not discharge gas into air.

Refrigerant characteristics

Type of refrigerant	R32
Safety class (ISO 817)	A2L
GWP	675

NOTE

- ▶ The refrigerant quantity is indicated on the unit plate

4. Before installation

4.1 Reception

You have to check before accepting the delivery:

- That the unit hasn't been damaged during transport
- That the materials delivered correspond with that indicated on the transport document comparing the data with the identification label positioned on the packaging.

In case of damage or anomaly:

- Write down on the transport document the damage you found and quote this sentence: "Conditional acceptance clear evidence of deficiencies/damages during transport"
- Contact by fax and registered mail with advice of receipt to supplier and the carrier.

WARNING

- ▶ **Any disputes must be made within 8 days from the date of the delivery. Complaints after this period are invalid.**

4.2 Storage

Observe external packaging instructions.

In particular:

minimum ambient temperature	(A)	-20°C
maximum ambient temperature	(B)	+49,5°C
maximum relative humidity	(C)	95%

Failure to comply with the above conditions can lead to:

- A possible components damages
- B possible safety valve opening
- C possible damages to electrical components

WARNING

- ▶ **The unit may not be tilted more than 15° during transport.**

4.3 Packaging removing

Be careful not to damage the unit.

Recycle and dispose of the packaging material in conformity with local regulations.

4.4 Handling

ATTENTION

- ▶ **Check that all handling equipment complies with local safety regulations (cran, forklifts, ropes, hooks, etc.).**
- ▶ **Provide personnel with personal protective equipment suitable for the situation, such as helmet, gloves, accident-prevention shoes, etc.**

- ▶ **Observe all safety procedures in order to guarantee the safety of the personnel present and the of material.**

- ▶ **Verify unit weight and handling equipment lifting capacity.**

- 1 Identify critical points during handling (disconnected routes, flights, steps, doors)
- 2 Protect the unit properly to prevent damage
- 3 Lifting with balance
- 4 Lifting with spacer bar
- 5 Align the barycenter to the lifting point
 - Gradually bring the lifting belts under tension, making sure they are positioned correctly
 - Before starting the handling, make sure that the unit is stable.

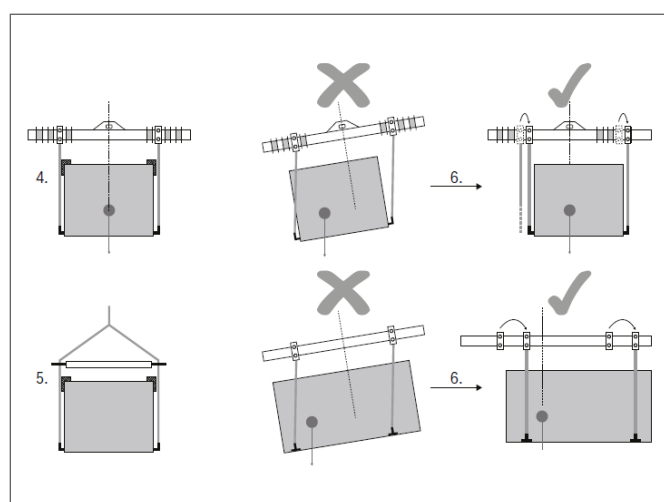

5. Selecting the installation site

5.1 General

Installation must be in accordance with local regulations. If they do not exist, follow EN378 .

During positioning consider these elements:

- customer approval
- unit weight and bearing point capacity
- safe accessible position
- functional spaces
- spaces for the air intake/exhaust
- Electrical connections
- max. distance allowed by the electrical connections
- Water connections

5.2 Maximum altitude of the installation

ATTENTION

- ▶ **Altitude: above 1000 m, reduce the maximum ambient temperature by 1°C every 200 m.**
- ▶ **Highest possible altitude 2000 m.**

5.3 Electromagnetic compatibility (EMC)

The units fulfil the emission and immunity requirements of the harmonised generic standards EN 61000-6-4:2007/ A11:2007 and EN 61000-6-2:2005/AC:2005 for industrial environments.

An industrial environment is defined as a site powered by a dedicated MV/LV transformer in compliance with the scope of the regulations applied.

5.4 Functional spaces

Functional spaces are designed to:

- guarantee good unit operation
- carry out maintenance operations
- protect authorized operators and exposed people

ATTENTION

- ▶ **Respect all functional spaces indicated in the DIMENSIONS section.**
- ▶ **Do not smoke or use open flames within this area**

5.5 Positioning

ATTENTION

- ▶ **Do not go up to the surface**
- ▶ **Do not place heavy loads.**

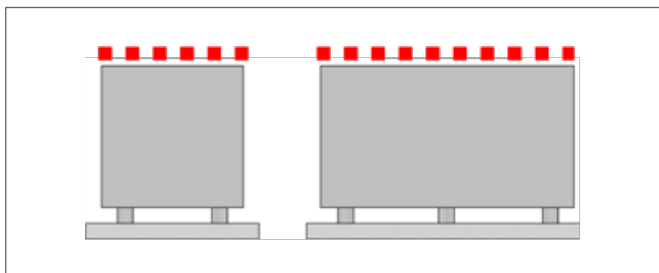

Units are designed to be installed:

- in fixed positions
- level

Put the unit in a position where any leaking gas cannot enter buildings or stagnate in closed areas. In the latter case, observe the rules for machinery rooms (ventilation, leak detection, etc.).

Choose the installation place according to the following criteria:

- avoid installations in places subject to flooding
- install the unit raised from the ground
- bearing points aligned and leveled
- discharged condensation water must not cause harm/ danger to people and property
- the accumulation of snow must not cause clogging of the coils

Limit vibration transmission:

- use anti-vibration devices or neoprene strips on the unit support points
- install flexible joints on the hydraulic and aeraulic connections

Protect the unit with suitable fence in order to avoid access to unauthorised personnel (children, vandals, etc.)

5.6 Air flow-rate on the coils

ATTENTION

- ▶ **The air flow must not be obstructed**

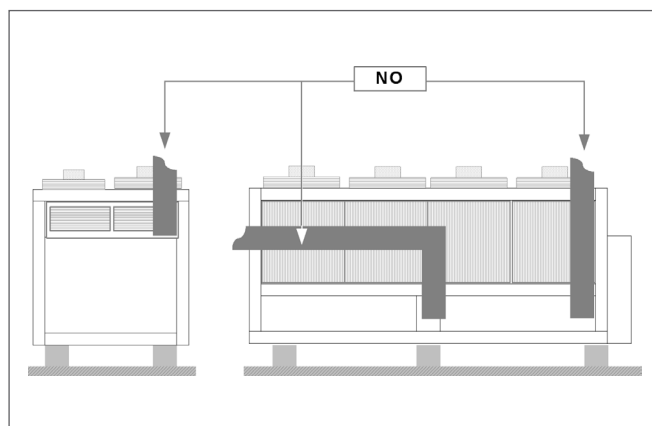

A correct circulation of the air is mandatory to guarantee the good unit operating.

Avoid therefore:

- obstacles to the airflow
- difficulty of exchange
- leaves or other foreign bodies that can obstruct the air coil
- winds that hinder or favour the airflow
- heat or pollution sources close to the unit (chimneys,

extractors etc.)

- stratification (cold air that stagnates at the bottom)
- recirculation (expelled air that is sucked in again)
- incorrect positioning, close to very high walls, attics or in angles that could give rise to stratification or recirculation phenomena

Ignoring the previous indications could:

- reduce energy efficiency
- alarm lockout due to HIGH PRESSURE (in summer) or LOW PRESSURE (in winter)

5.7 Safety valve gas side

The installer is responsible for evaluating the opportunity of installing drain tubes, in conformity with the local regulations in force (EN 378).

If ducted, the valves must be sized according to EN13136.

6. Water connections

6.1 Hydraulic system

The pipes must be designed and manufactured to limit pressure drops as much as possible, i.e. optimise performance of the system.

Keep the following parameters to a minimum:

- overall length
- number of bends
- number of vertical changes of direction

6.2 Water quality

The water quality must be checked by qualified personnel.

Water with inadequate characteristics can cause:

- pressure drop increase
- reduces energy efficiency
- increased corrosion potential

Water features:

- within the limits indicated by table

Provide a water treatment system if values fall outside the limits.

6.3 Cleanliness

Before connecting the water to the unit, clean the system thoroughly with specific products effective to remove residues or impurities that may affect functioning. Existing systems must be free from sludge and contaminants and protected against build-ups.

6.4 New systems

In case of new installations, it is essential to wash the entire installation (with the circulator uninstalled) before commissioning the central installation. This removes residues of the installation process (welding, waste, joint products...).

The system must then be filled with clean high-quality tap water.

6.5 Existing systems

If a new unit is installed on an existing system, the system must be rinsed to avoid the presence of particles, sludge and waste.

The system must be drained before installing the new unit.

Dirt can be removed only with a suitable water flow.

Particular attention must also be paid to “blind spots” where a lot of dirt can accumulate due to the reduced water flow.

If, after rinsing, the quality of the water is still unsuitable, a few measures must be taken to avoid problems.

An option to remove pollutants is to install a filter.

- ▶ **The warranty does not cover damages caused by limestone formations, deposits and impurities from the water supply and/or from failure to clean the systems.**

Water component for corrosion limit on Copper	
PH (25°C)	7,5 ÷ 9,0
SO4--	< 100
HCO3- / SO4--	> 1
Total Hardness	8 ÷ 15 °f
Cl-	< 50 ppm
PO4 3-	< 2,0 ppm
NH3	< 0,5 ppm
Free Chlorine	< 0,5 ppm
Fe3 +	< 0,5 ppm
Mn++	< 0,05 ppm
CO2	< 50
H2S	< 50 ppb
Oxygen content	< 0,1 ppm
Sand	10 mg/L
Ferrite hydroxide Fe3O4 (black)	Dose < 7.5 mg/L 50% of mass diameter < 10 µm
Iron oxide Fe2O3 (red)	Dose < 7.5mg/L Diameter < 1 µm
Electrical conductivity (µS/cm)	<500
Sodium nitrate (mgNaNo3/l)	<100
Alkalinity(mgCaCo3/l)	<100
Copper (mgCu/l)	<1.0
Sulphide ion (S-/l)	None
Ammonium ion (mgNH4+/L)	<1.0
Silica (mgSiO2/l)	50
Max Ethylene, Propylene glycol	50%
Nitrates	<100
Free&aggressive Carbonic Acid	<5

ATTENTION

6.6 Risk of freezing

If the unit or the relative water connections are subject to temperatures close to 0°C:

- mix water with glycol, or
- safeguard the pipes with heating cables placed under the insulation, or
- empty the system in cases of long non-use

6.7 Anti-freeze solution

The use of an anti-freeze solution results in an increase in pressure drop.

Make sure that the glycol type utilized is inhibited (not corrosive) and compatible with the water circuit components.

Do not use different glycol mixture (i.e. ethylene with propylene).

ATTENTION

- ▶ **The unit must always be protected from freeze. Otherwise irreversible damage may occur.**

% GLYCOL ETHYLENE / PROPYLENE BY WEIGHT		5%	10%	15%	20%	25%	30%	35%	40%	45%	50%
Freezing temperature	°C	-2	-3.9	-6.5	-8.9	-11.8	-15.6	-19.0	-23.4	-27.8	-32.7
Safety temperature	°C	3	1	-1	-4	-6	-10	-14	-19	-23.8	-29.4

6.8 Water flow-rate

The project water-flow must be:

- inside the exchanger operating limits (see the TECHNICAL INFORMATION section)
- guarantee, also with variable system conditions (for example in systems where some circuits are bypassed in particular situations).

If the system capacity is below the minimum flow, bypass the system as indicated in the diagram.

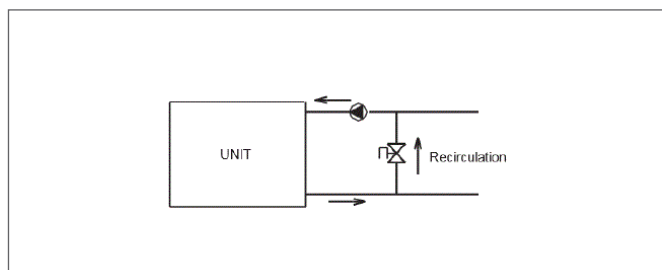

If the system capacity exceeds the minimum flow, bypass the system as indicated in the diagram.

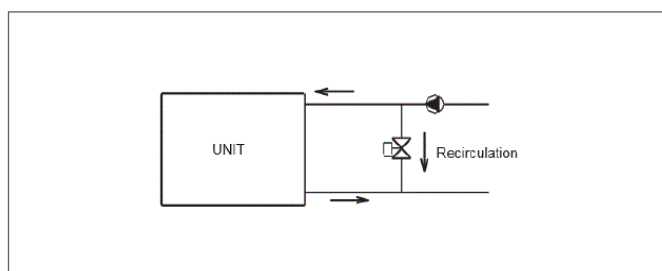

6.9 Minimum system water content

Minimum system water volumes are described within chapter TECHNICAL DATA and they have to be satisfied for a proper functioning of the unit.

6.10 Flow Switch

The flow switch must be present to ensure shutdown of the unit if water is not circulating.

It has to be installed in a duct rectilinear part, not in proximity of curves that cause turbulences.

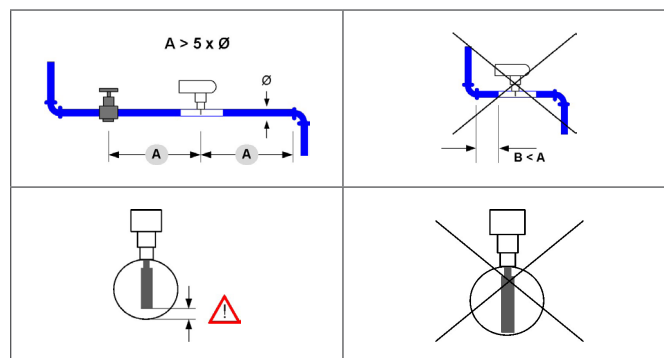

6.11 Water filter

Must be installed immediately in the water input of the unit, in a position that is easily accessible for cleaning.

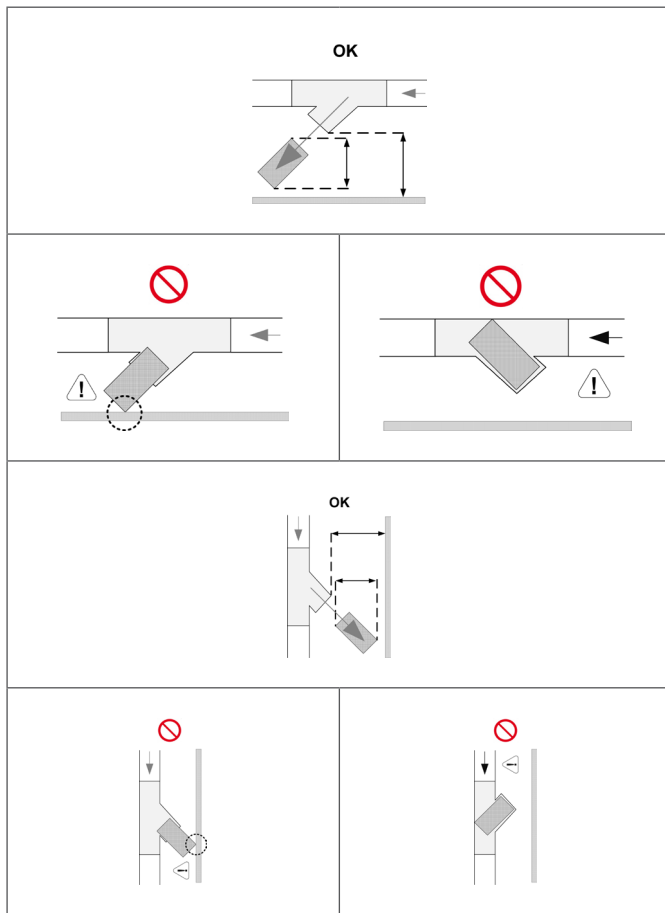

The filter must have an adequate mesh to prevent the entry of particles greater than:

plate exchanger (mm)	0,9
----------------------	-----

ATTENTION

- ▶ The filter never should be removed, this operation invalidates the guaranty.

6.12 Non-return valve

Provide for the installation of non-return valves (A) in the case of several units connected in parallel.

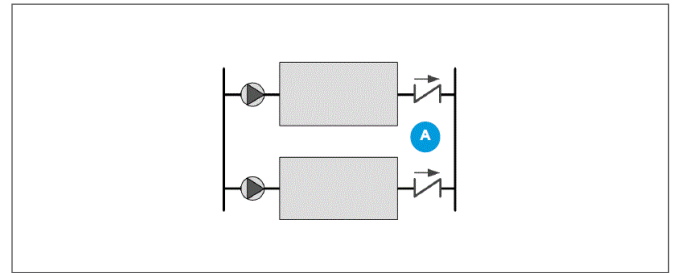

6.13 Operation sequence

Before starting the unit pump:

- 1 Close all vent valves in the high points of the unit hydraulic circuit
- 2 Close all drain shut-off valves in the low points of the unit's water circuit
exchangers
pumps
collectors
storage tanks
- 3 Carefully wash the system with clean water: fill and drain the system several times.
- 4 use the bypass to exclude the exchanger from the flow (diagram on the previous page)
- 5 fill and empty the system multiple times.
- 6 Apply additives to prevent corrosion, fouling, formation of mud and algae.
- 7 Fill the plant
- 8 do not use the unit pump.
- 9 Execute leakage test.
- 10 Isolate the pipes to avoid heat dispersions and formation of condensate.
Leave various service points free (wells, vents, etc).

ATTENTION

- ▶ Neglecting the washing will lead to several filter cleaning interventions and at worst cases can cause damages to the exchangers and the other parts.

6.14 Hydronic units and connection diagrams recommended

The installer must define:

- type of components
- position in the system

See diagrams on the next pages.

6.15 Standard unit

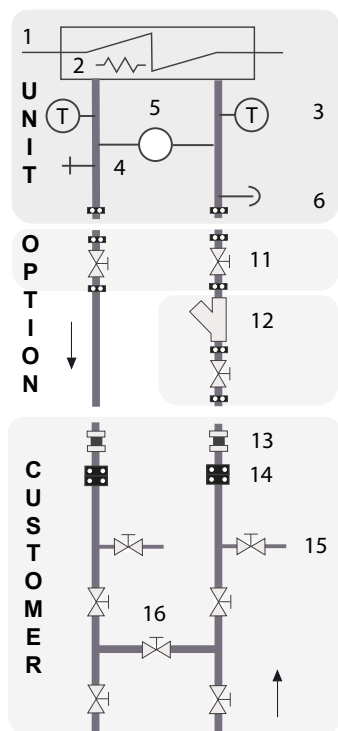

6.16 Unit + pump

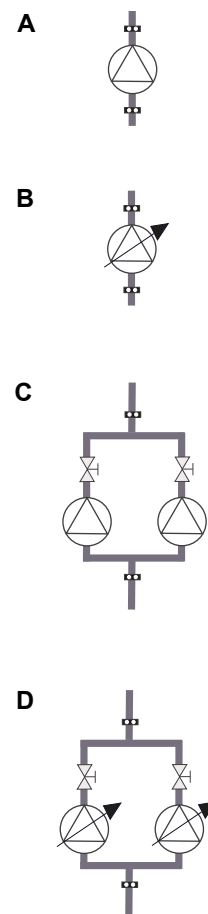
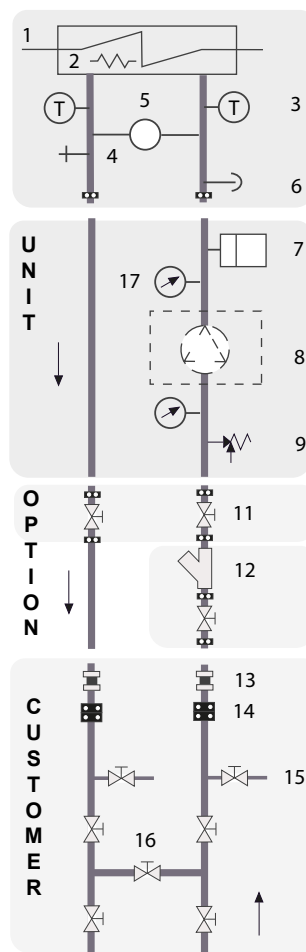

- | | |
|--|--|
| <ul style="list-style-type: none"> 1 Exchanger 2 Antifreeze heater 3 Water temperature probe 4 Drain 5 differential pressure switch 6 vent 7 system load safety pressure switch 8 pump 9 safety valve 10 inertial tank | <ul style="list-style-type: none"> 11 shut-off valves 12 filter 13 flexible couplings 14 piping supports 15 Exchanger chemical cleaning bypass 16 system washing bypass (interlock closed during operation) 17 pressure gauge |
|--|--|

7, 9, 17

Components on board the unit only if the unit is equipped with pumps; otherwise the supply of these is the responsibility of the Customer.

6.17 Unit + water tank

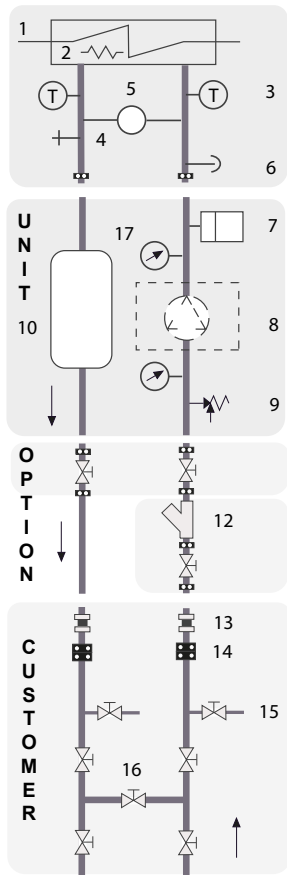

- | | |
|--|--|
| <ul style="list-style-type: none"> 1 Exchanger 2 Antifreeze heater 3 Water temperature probe 4 Drain 5 differential pressure switch 6 vent 7 system load safety pressure switch 8 pump 9 safety valve 10 inertial tank | <ul style="list-style-type: none"> 11 shut-off valves 12 filter 13 flexible couplings 14 piping supports 15 Exchanger chemical cleaning bypass 16 System washing bypass (interlock closed during operation) 17 pressure gauge |
|--|--|

7, 9, 17	Components on board the unit only if the unit is equipped with pumps; otherwise the supply of these is the responsibility of the Customer.
-----------------	--

6.18 Unit in modular configuration

See specific chapter at the end of the manual.

7. Electrical connections

The characteristics of the electrical lines must be determined by qualified electrical personnel able to design electrical installations; moreover, the lines must be in conformity with regulations in force.

The protection devices of the unit power line must be able to stop all short circuit current, the value must be determined in accordance with system features.

The power cables and the protection cable section must be defined in accordance with the characteristics of the protections adopted.

All electrical operations should be performed by trained personnel having the necessary qualifications required by the regulations in force and being informed about the risks relevant to these activities.

Operate in compliance with safety regulations in force.

7.1 Electrical data

The serial number label reports the unit specific electrical data, included any electrical accessories.

The electrical data indicated in the technical bulletin and in the manual refer to the standard unit, accessories excluded.

The matriculation plate shows the indications foreseen by the standards, in particular:

Voltage

F.L.A.: full load ampere, absorbed current at maximum admitted conditions

F.L.I.: full load input, full load power input at max. admissible condition

Electrical wiring diagram Nr.

7.2 Connections

- 1 Refer to the unit electrical diagram (the number of the diagram is shown on the serial number label).
- 2 Verify that the electrical supply has characteristics conforming to the data shown on the serial number label.
- 3 Before starting work, ensure the unit is isolated, unable to be turned on and a safety sign used.
- 4 Ensure correct earth connection.
- 5 Ensure cables are suitably protected.
- 6 Prevent dust, insects or rodents from entering the electrical panel as they can damage components and cables.
- 7 Use the special holes on the bottom of the frame for the power line inlet. Seal any residual openings to prevent noise from escaping the compressors compartment.
- 8 Fix the cables: if vacated, they may be subject to tearing.
- 9 The cables must not touch the compressor and the refrigerant piping (they reach high temperatures).
- 10 Do not drill holes in the electrical panel.

- 11 Alternatively, restore the IP rating with watertight systems.
- 12 Before power the unit, make sure that all the protections that were removed during the electrical connection work have been restored.

7.3 Power supply network requirements

- 1 The short circuit capacity of the line must be less than 10 kA
- 2 The units can only be connected to TN, TT distribution systems
- 3 Voltage 400-3-50 +/-10%
- 4 Phase unbalance < 2%
- 5 Harmonic distortion less than 12% (THDv<12%)
- 6 Voltage interruptions lasting no longer than 3ms and with at least 1 s between each one
- 7 Voltage dips not exceeding 20% of the RMS value, lasting no longer than a single period (50Hz) and with at least 1 s between each dip.
- 8 Leakage current exceeding 10 mA and installation in accordance with Section 8.2.6 of the standard.
- 9 Earth cable as specified in the table:

Cross-section of the line conductors (mm ²)	Minimum cross-section of the protective conductor (PE) (mm ²)
S ≤ 16	S
16 < S ≤ 35	16
S > 35	S/2

7.4 Signals / data lines

Do not exceed the maximum power allowed, which varies, according to the type of signal.

Lay the cables far from power cables or cables having a different tension and that are able to emit electromagnetic disturbances.

Do not lay the cable near devices which can generate electromagnetic interferences.

Do not lay the cables parallel to other cables, cable crossings are possible, only if laid at 90°.

The type of cable must be suitable for RS-485 serial data communication.

A 3-pole shielded bus cable is required.

The data transmission bus cable must be verified according to the type of installation in which it will be placed and must comply with local standards.

The bus cable must comply with non-prescribed local electrical standards (e.g. insulation, voltages, flame

propagation, etc.).

The cable shield must be grounded at a single point free from disturbances.

In order to ensure correct communication, the earth connection of the shield can also be configured differently depending on the area and the types of

interference.

Allowed topology: daisy-chain (enter and exit).

Other types such as "ring" or "star" are not allowed.

Do not use cable lugs on the communication bus.

7.5 Power line inlet.

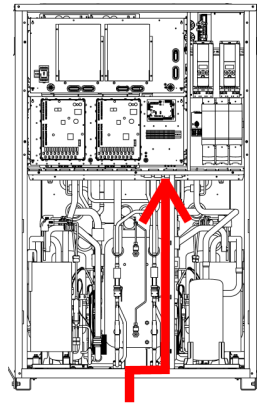

7.6 Controller wiring sections

	45.4	50.4	55.4	60.4	65.4
Cu cable cross-section (mm ²)	35 - 90	35 - 90	35 - 90	95 - 240	95 - 240
Tightening torque (Nm)	9	9	9	20	20
	70.4	75.4	80.4	85.4	90.4
Min. cable section Cu (mm ²)	95 - 240	185 - 240	185 - 240	185 - 240	185 - 240
Tightening torque (Nm)	20	20	20	20	20

7.7 Remote ON-OFF

Do not perform short On-Off cycles.

Do not use the remote On-Off with a thermoregulation function.

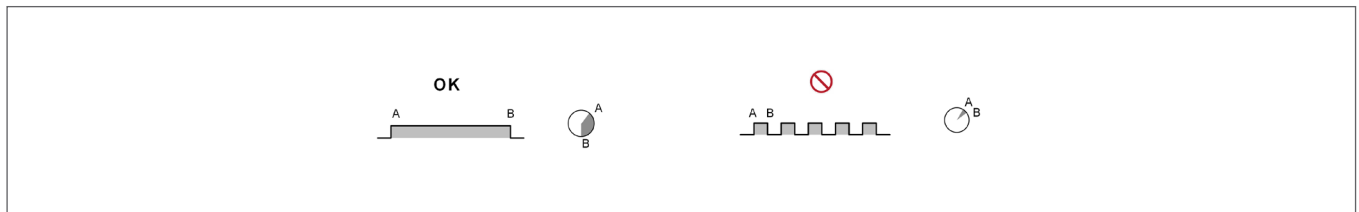

7.8 Connections performed by Customer

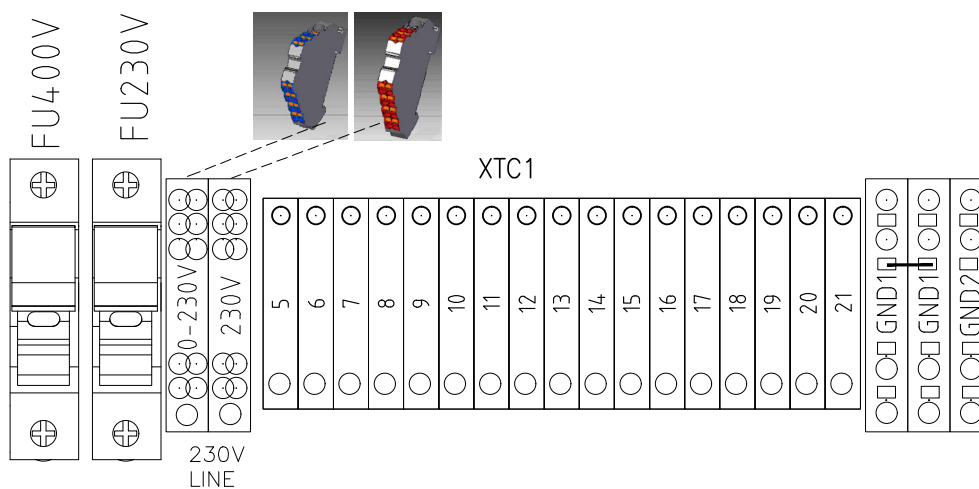

Function		Terminal block Connector	Terminals	Type of contact
System load pressure switch Connect only if standard unit without pumps on board	WP.-SW	XTC1	13 gnd	
Cooling Heating	COOL/HEAT	XTC1	14 gnd	
On - Off	ON/OFF	XTC1	15 gnd	
2nd setpoint	TEMP-SW	XTC1	20 gnd	
Connection bus for units in multiple configuration / double keypad	MideaBus	XTC1	5 - X 6 - E 7 - Y	
Signalling alarm	Alarm	CN85		max 240V AC 5A
Heating elements	KM1	CN26	Heat1 Com	max 240V AC 5A
Heating elements	KM2	CN26	Heat2 Com	max 240V AC 5A
Compressor status	HL1	CN33		max 240V AC 5A
Compressor status	HL2	CN33 slave board		max 240V AC 5A

7.9 Remote control of the unit

With S5_3 ON, the unit is controlled remotely.

The wired controller is disabled.

ON/OFF status controlled by the On/Off input:

- input ON = unit ON

Heat/Cool mode controlled by the Heat/Cool input:

- On = heating, Off = Cooling

Double setpoint controlled by the TEMP-SW contact:

- input ON = 2nd setpoint

With the units in modular configuration, remote control must be applied to the master unit, which transmits it to

the slave units.

After setting S5_3, disconnect and reconnect the power supply to confirm the change.

7.10 Remote control of the unit

With the additional board option for advanced REMAU function management

See the diagram on the next page.

With S5_3 OFF, see the instructions of the separately supplied accessory for operation.

The ON/OFF or Heat/Cool enabling function cannot be wired on the customer's terminal block and enabled on the REMAU at the same time. This can create conflicts.

7.11 Position of REMAU board

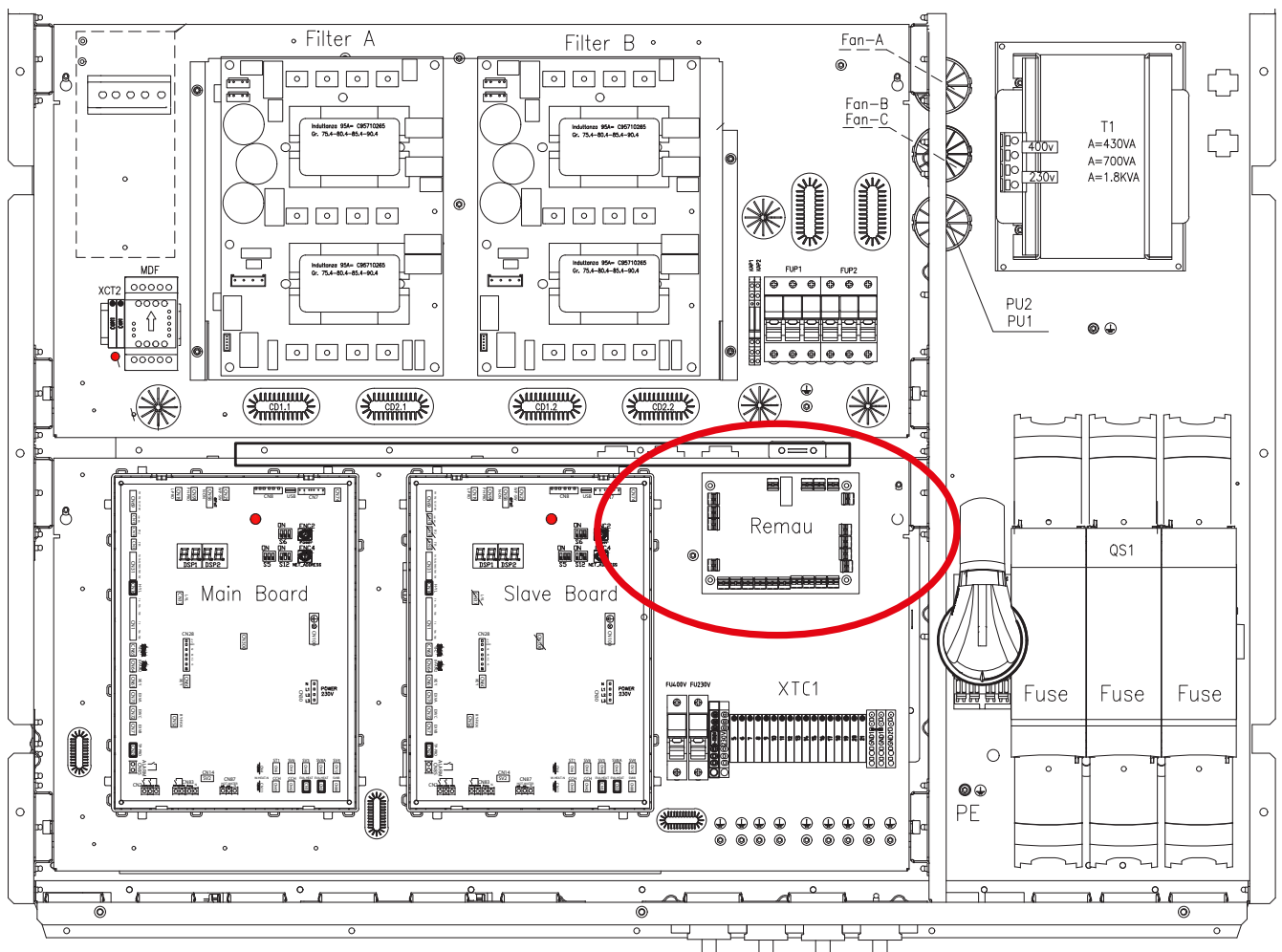

7.12 Connections performed by customer - unit with REMAU

SA4	Selettore on/off remoto Remote on/off selector Sélecteur ON/OFF déporté Fernwahlschalter Ein/Aus Selector on/off remoto	SA7	Selettore abilitazione secondo set-point Second set-point enabling switch Sélecteur validation deuxième consigne Wahlschalter 2.Sollwert Selector habilitación segundo set-point	SA22	Selettore abilitazione Smart Grid Smart Grid enabling selector Sélecteur d'activation Smart Grid Smart Grid aktivierender Selektor Selector de habilitación Smart Grid
SA5	Selettore remoto "heating/cooling" Remote "heating/cooling" selector Sélecteur déporté "heating/cooling" Fernwahlschalter "heating/cooling" Selector remoto "heating/cooling"	SA8	Selettore abilitazione modo silenzioso Silent mode enabling selector Sélecteur d'activation du mode silencieux Selektor zur Aktivierung des Silent-Modus Selector de habilitación del modo silencioso	REMAU BMS	Sistema di comunicazione BMS / Modbus RTU BMS / Modbus RTU communication system Système de communication BMS / Modbus RTU BMS / Modbus RTU-Kommunikationssystem Sistema de comunicación BMS / Modbus RTU
SA6	Selettore richiesta acqua sanitaria Sanitary water cycle selector Sélecteur demande eau sanitaire Wahlschalter der Brauchwasser Selector solicitud agua sanitaria	SA21	Selettore abilitazione EVU EVU enabling selector Sélecteur d'activation EVU EVU-Aktivierungsselektor Selector de habilitación de EVU		

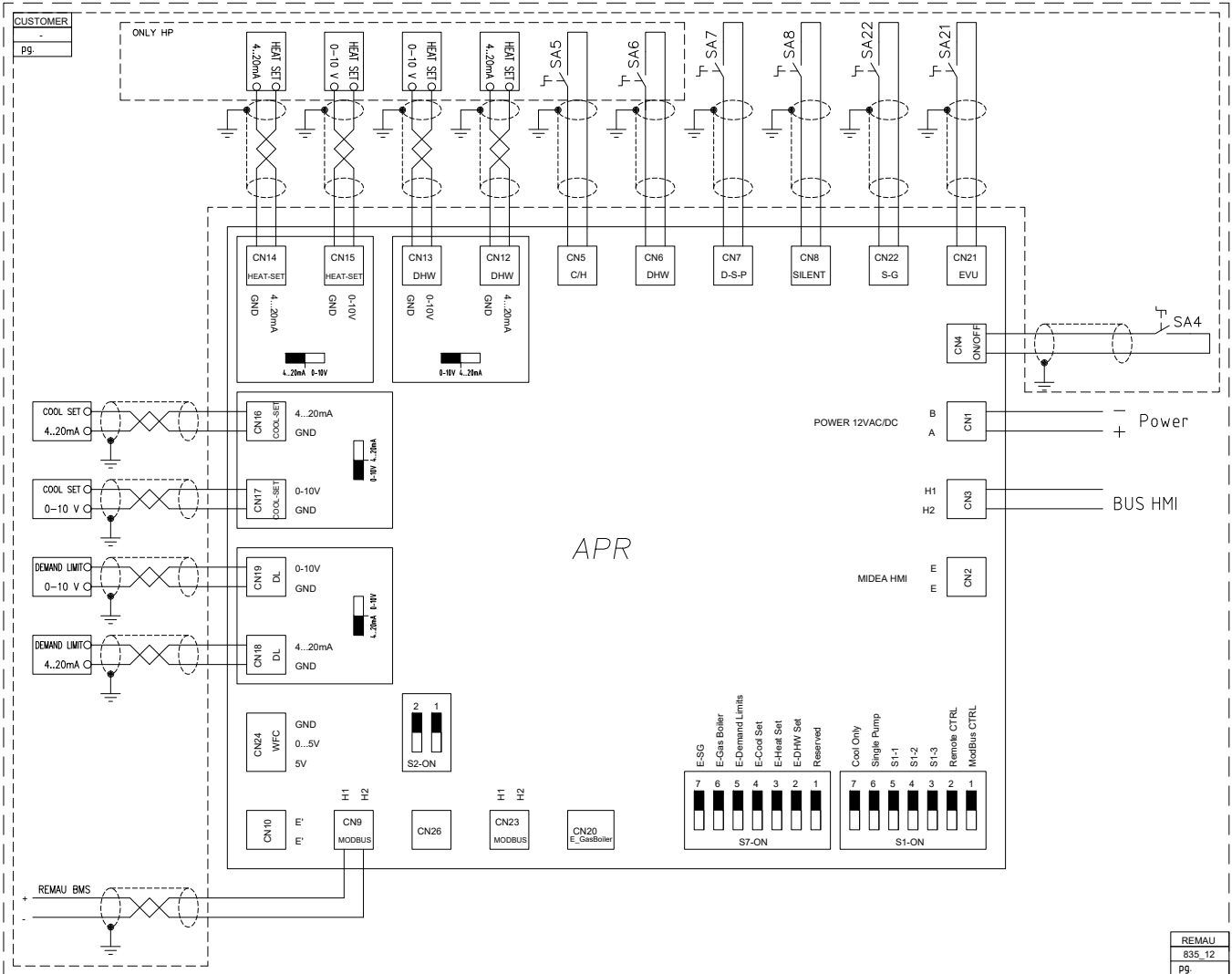

REMAU
835_12
P9

7.13 TW probe

- The total system supply water flow control probe is installed on the supply pipe in the fan compartment.
- With the unit in modular configuration, the TW probe of the master unit must be re-installed as far away as possible on the common supply line of the system. Use the additional probe support in the electrical panel. Maintain the connection to the electrical panel, only remove the sensor fitted in the support inside the water supply pipe. The probe is secured by a sealing gland.
- Contact on XT2 board: 1-2.

7.14 Taf1 probe

- The domestic hot water antifreeze protection probe is in a plastic bag with a 10 m long cable inside the electrical panel.
- To control the Taf1 probe remotely, electrically disconnect the cable in the electrical panel (only 3 m long) and connect the cable in the bag marked Taf1 to the same connector. Install the probe on the discharge pipe from the hot water inertial tank.
- Contact on APC board: 7-8.

7.15 T5 probe

- The temperature probe that switches from the system to domestic hot water is in a plastic bag with a 10 m long cable inside the electrical panel. Connect it to the free connector marked "T5" in the electrical panel.
- Contact on XT2 board: 3-4.

7.16 Alarm signal

ALARM

- Closed contact with the unit in alarm.
- Contact on APC board: CN24_1-2.

7.17 Compressor running signal

HL1

- Connect the warning light as shown in the diagram.
- Contact on APC board: CN33_COMP-STATE.

7.18 External pump control

PUMP-N

- If a unit is supplied without a circulation pump, control the external pump as shown in the diagram. Use an auxiliary relay.
- Contact on APC board: CN25_PUMP-N.

7.19 Use remote keypad control

The keypad is wired on the unit

It can be disassembled and installed remotely.

Connection up to 40 m.

Power supply provided by the unit.

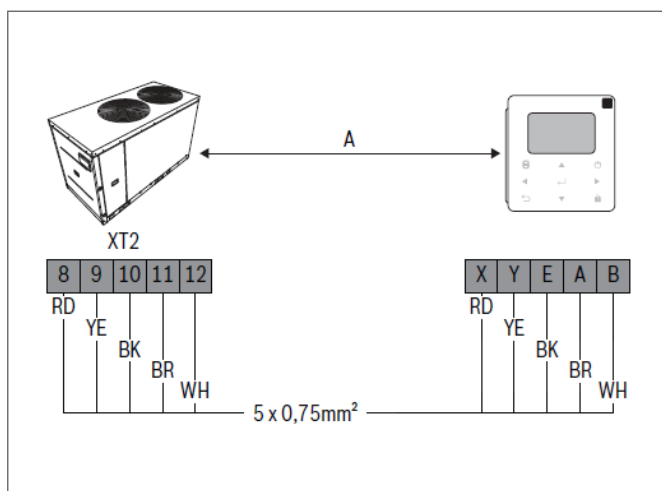

Connection up to 300 m.

Separate power supply.

Power output provided with the unit.

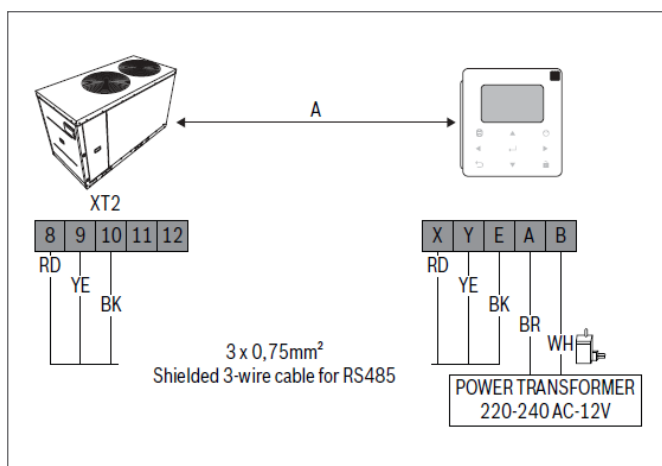

7.20 Modbus

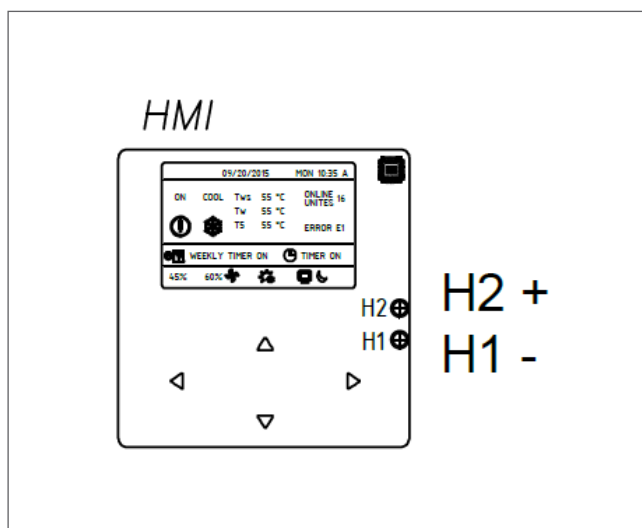

7.21 Double keypad

If the double keypad option has been selected:

- possibility of having a keypad on the unit and a remote keypad. One will be for display only.
- ▶ **External power output required for remote keypad (included in the option).**
- ▶ **Refer to the service manual for configuration.**
- ▶ **Refer to the “Use remote keypad control” chapter for the maximum distance.**

8. Start-up

The operations indicated should be performed by qualified technicians with specific training on the product.

Upon request, the service centres can perform the start-up.

The electric, hydraulic connections and the other work of the system are the responsibility of the installer.

Please agree upon the start-up data with the service centre with sufficient advance.

Before checking, please verify the following:

- the unit should be installed properly and in compliance with this manual
- the electrical power supply line should be isolated at the beginning
- the unit isolator is open, locked and equipped with the suitable warning
- make sure no tension is present

Attention

- ▶ **After turning off the power, wait at least 5 minutes before accessing to the electrical panel or any other electrical component.**
- ▶ **Before accessing check with a multimeter that there are no residual stresses.**

8.1 Start-up sequence

For details refer to the different manual sections.

Unit OFF power supply

		✓
1	safety access	
2	suitable frame to withstand unit weight + people weight	
3	functional spaces	
4	air flow: correct return and supply (no bypass, no stratification)	
5	considered level to be reachable by snow	
6	considered main winds: there are deflectors, windbreaks, suitable anchor system	
7	lack of chimneys / corrosive atmospheres / pollutants	
8	structure integrity	
9	fans run freely	
10	unit on vibration isolators	
11	unit on level ground	
12	there is condensate drainage (only for heat pump units)	
13	unit input water filter + shut-off valves for cleaning	
14	hydraulic connections as per recommended diagram	
15	expansion tank (indicative volume = 5% system content)	
16	minimum system water content	
17	cleaned system	
18	loaded system + possible glycol solution + corrosion inhibitor	
19	antifreeze protections: glycol solution + possible heating cable	
20	system under pressure + vented	
21	refrigerant circuit visual check	
22	earthing connection	
23	power supply features	
24	Customer care connections: electrically connected, configured	

8.2 Start-up sequence

For details refer to the different manual sections.

Unit ON power supply

		✓
1	compressor crankcase heaters operating at least since 8 hours	
2	off-load voltage measure	
3	phase sequence check	
4	pump manual start-up and flow check	
5	shut-off valve refrigerant circuit open	
6	unit ON	
7	load voltage measure	
8	verify the lack of bubbles in the liquid light (if applicable)	
9	check of all fan operating: no abnormal noises or vibrations	
10	measure return and supply water temperature	
11	measure super-heating and sub-cooling	
12	run tests in both heat and cool mode (only for heat pump units)	
13	check no anomalous vibrations are present	
14	climatic curve personalization	
15	scheduling customisation	
16	check that all panels are closed and fastened properly	
17	complete and available unit documentation	

8.3 Refrigeration circuit

- 1 Check carefully the refrigerating circuit: the presence of oil stains can mean leakage caused by transportation, movements or other).
- 2 Verify that the refrigerating circuit is in pressure: Using the unit manometers, if present, or service manometers.
- 3 Make sure that all the service outlets are closed with proper caps; if caps are not present a leak of refrigerant can be possible.
- 4 Open the valves of the refrigerant circuit, if there are any.

8.4 Electric Circuit

- 1 Verify that the unit is connected to the ground plant.
- 2 Check the conductors are tightened as: the vibrations caused by handling and transport might cause these to come loose.
- 3 Connect the unit by closing the sectioning device, but leave it on OFF.
- 4 Check the voltage and line frequency values which must be within the limits: 400/3/50 +/- 10%
- 5 Check and adjust the phase balance as necessary: it must be lower than 2%

Attention

- ▶ **Working outside of these limits can cause irreversible damages and voids the warranty.**

8.5 Options

Menu accessible only after having entered the password.

Access reserved only to specifically trained personnel.

Changing the parameters can cause irreversible damage.

8.6 Start-up report

Identifying the operating objective conditions is useful to control the unit over time.

With unit at steady state, i.e. in stable and close-to-work conditions, identify the following data:

- total voltages and absorptions with unit at full load
- absorptions of the different electric loads (compressors, fans, pumps etc)
- temperatures and flows of the different fluids (water, air) both in input and in output from the unit
- temperature and pressures on the characteristic points of the refrigerating circuit (compressor discharge, liquid, intake)

The measurements must be kept and made available during maintenance interventions.

8.7 2014/68/UE PED directive

DIRECTIVE 2014/68/UE PED gives instructions for installers, users and maintenance technicians as well.

Refer to local regulations; briefly and as an example, see the following:

Compulsory verification of the first installation:

- only for units assembled on the installer's building site (for ex. Condensing circuit + direct expansion unit)

Certification of setting in service:

- for all the units

Periodical verifications:

- to be executed with the frequency indicated by the Manufacturer (see the "maintenance inspections" paragraph)

8.8 Free cooling

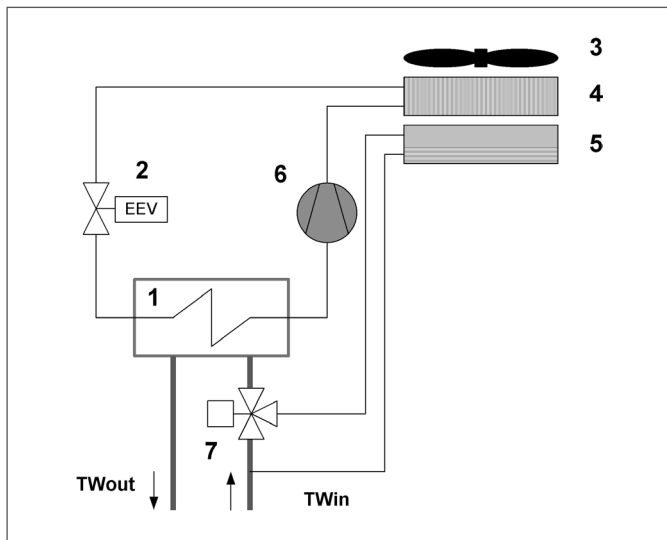

- 1 Exchanger
- 2 Thermostatic valve
- 3 Fan
- 4 Coil
- 5 Free cooling coil
- 6 Compressor
- 7 3-way valves

Mode: compressor only

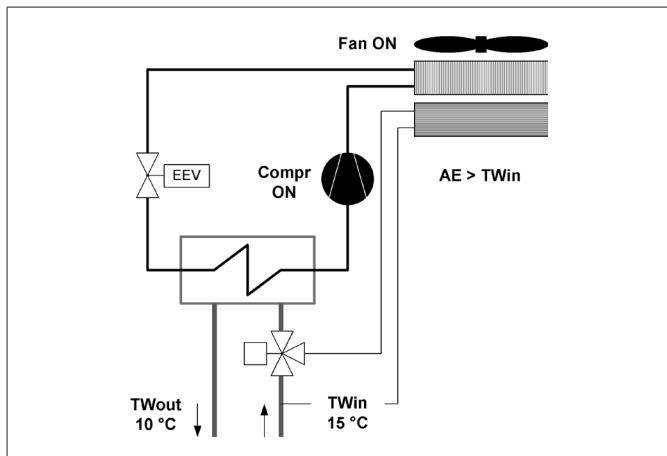

Mode: compressor + free cooling

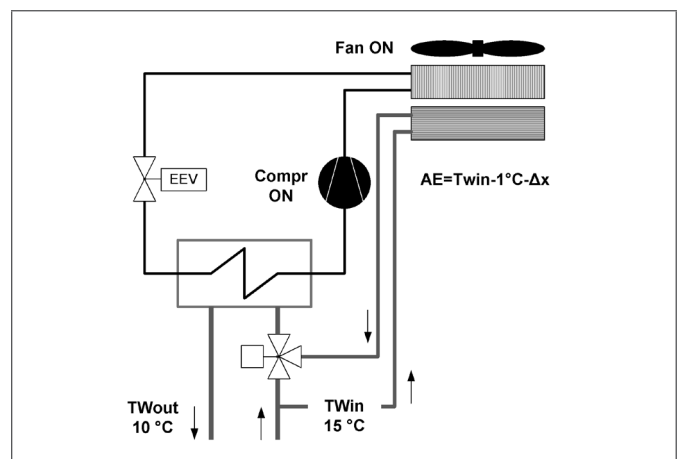

Mode: Free cooling

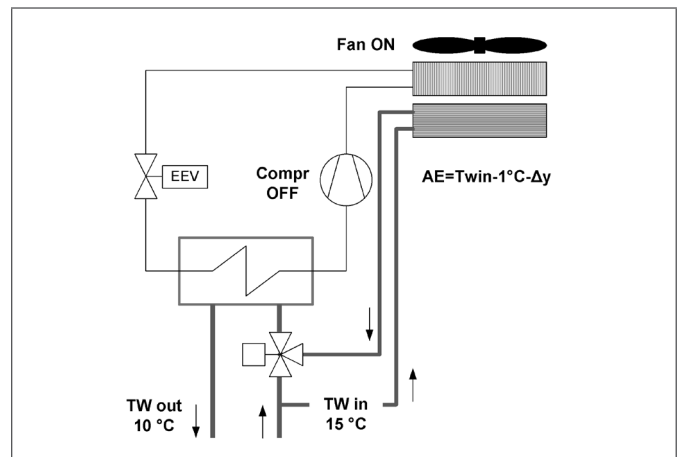

Mode: Compressor off + Free cooling off

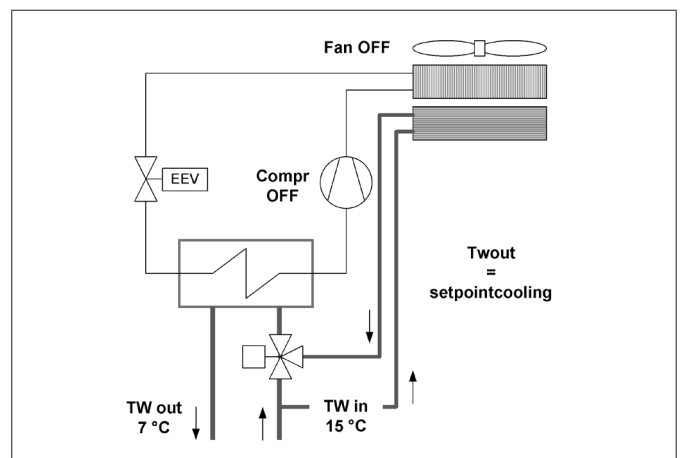







9. Control

9.1 Panel



9.2 Buttons

Button	Name	Function
	UNLOCK	Locks/unlocks the buttons
	UP DOWN	Changes the current setpoint
	MENU	Opens the various menus from the HOME screen
	UP DOWN LEFT RIGHT	Moves the cursor, changes the selection, changes the set value.
	ENTER	Confirms an operation.
	ON OFF	Switches on/off.
	BACK	Returns to the previous level/page.

9.3 Lock/Unlock keys

Press for 3 seconds.	
----------------------	---

9.4 Switch-On/Off















Press	
-------	---

9.5 Unit in modular configuration

The information displayed on ALL controllers refers to the MASTER unit.

On the slave controllers, only the password-protected SERVICE menu can be opened.

9.6 Display

Icon	Meaning
 Comp	COMP mode (compressors only)
 Mix	Heating
 FC	FC mode (Free Cooling)
OFF	Controller off
	Weekly timer active
	Compressor in operation
	Fan in operation
	Pump in operation
	Backup electric heater in operation
	Manual antifreeze or defrosting in operation
	Remote control: the unit is set from the keypad to be controlled by a remote terminal or by a remote selector switch.
	SILENT MODE
	Button lock
	Timer active
	Alarm: indicator on when there is a fault or a protection is tripped.

9.7 Set Date, Time, Language

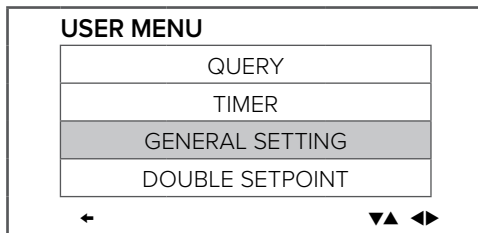
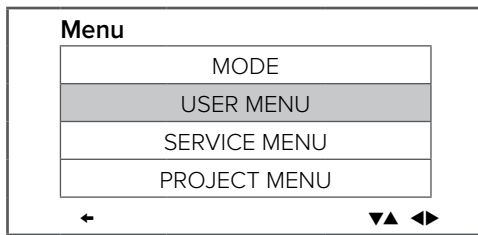

GENERAL SETTING	
YEAR	◀ 2022 ▶
MONTH	◀ 7 ▶
Day	◀ 6 ▶
12-24HOUR	◀ 12 ▶
Time	◀ 10 ▶
← 1/2 ▼▲▶◀▶	

GENERAL SETTING	
MINUTE	◀ 55 ▶
AM/PM	◀ AM ▶
LANGUAGE	◀ ▶
BACKLIGHT OFF DELAY(s)	◀ 60 ▶
← 2/2 ▼▲▶◀▶	

9.8 Set MODE and TEMPERATURE

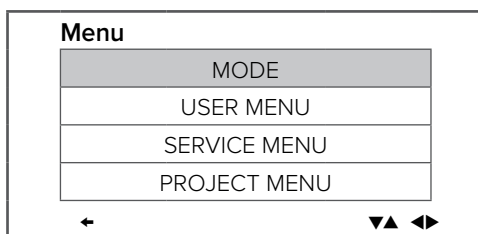

Press	⊞
Select Mode	▲▼
Confirm	↵
Select the mode or the temperature	◀▶

Control the mode or the temperature	▲▼
Confirm	↵

If no operations are performed for more than 60 seconds, the system automatically saves the mode setting and returns to the home page.

9.9 Double setpoint

The unit is capable of handling two different setpoints, in both heating and cooling modes.

The value can be set with the user interface.

Activation is via a dry contact on the specific terminal block.

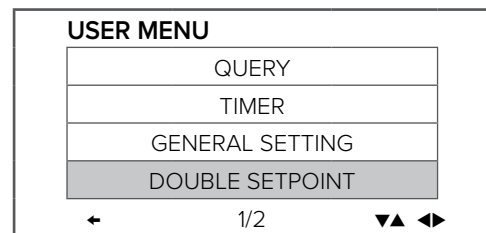
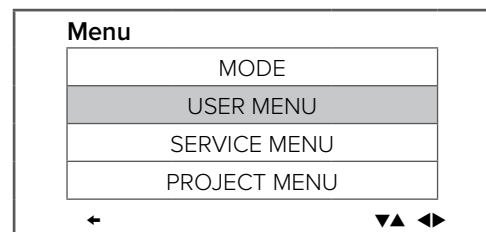

DOUBLE SETPOINT	
DOUBLE SETPOINT	◀ DISABLE ▶
SETPOINT COOL_1	◀ 7 ▶ °C
SETPOINT COOL_2	◀ 10 ▶ °C
SETPOINT HEAT_1	◀ 35 ▶ °C
SETPOINT HEAT_2	◀ 30 ▶ °C
← ▼▲▶◀▶	

9.10 Snow protection function

If enabled, the function activates the fans in order to prevent a build-up of snow.

The fans start for 2 minutes every 30 minutes when the air temperature is below 3°C and the unit is stopped.

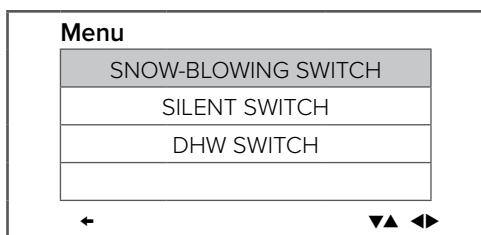
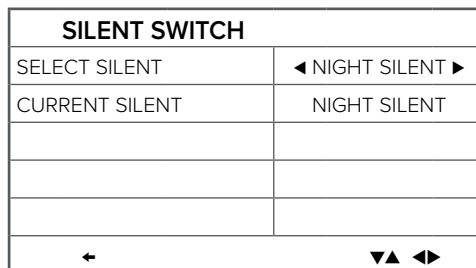
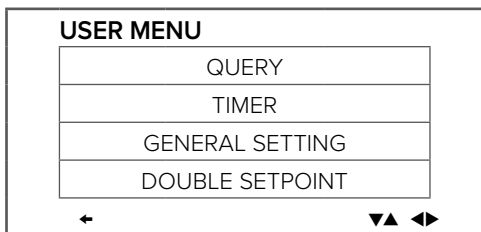
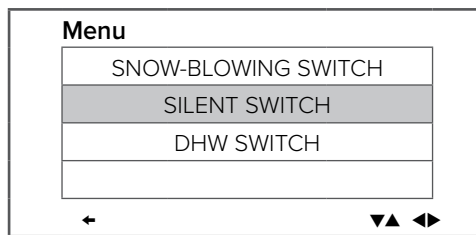
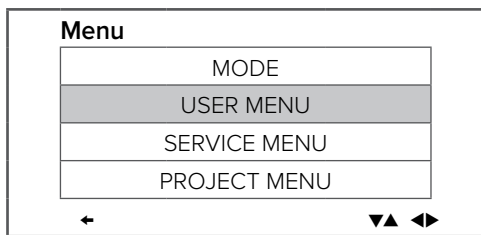

9.12 Querying variables

The function displays some unit variables: operation status, temperatures, alarm history.

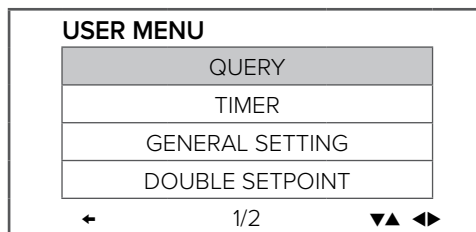
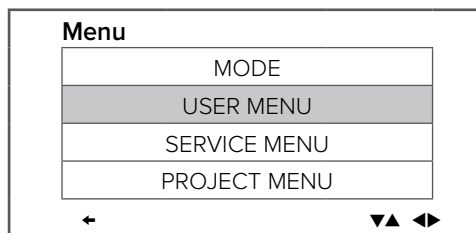
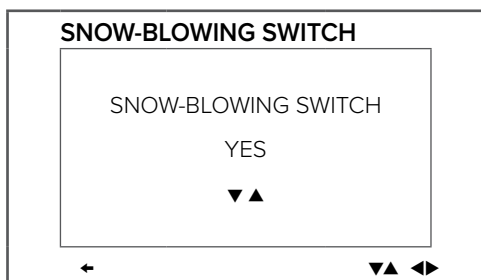

9.11 Silent mode

The SILENT MODE function lowers the sound emission level, which is especially useful at night.

The compressor and fan speed is reduced.

There are three silence levels available: Standard, Silent, Super silent.

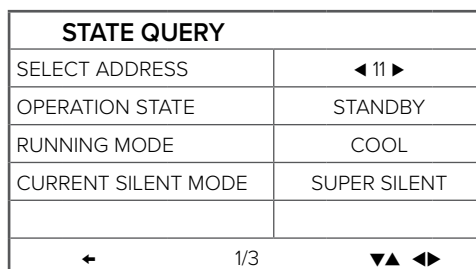
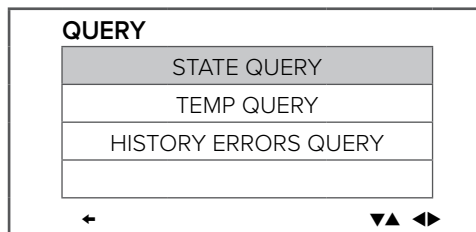
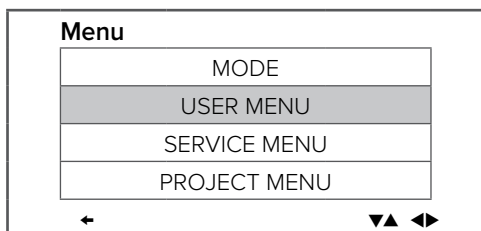

STATE QUERY	
CURRENT CAPACITY	100 KW
CURRENT POWER	50 KW
CURRENT EFFICIENCY	2
TOTAL CAPACITY	100 MW
TOTAL POWER	50 MW
← 2/3 ▼▲▶	

QUERY
STATE QUERY
TEMP QUERY
HISTORY ERRORS QUERY
← ▼▲▶

STATE QUERY	
TOTAL POWER	50 MW
← 3/3 ▼▲▶	

HISTORY ERRORS QUERY	
SELECT ADDRESS	◀ 11 ▶
1 2 3 4 5 6 7 8	
EU: 11/03/2020 15:05	
Tz sensor error	
← ▼▲▶	

QUERY
STATE QUERY
TEMP QUERY
HISTORY ERRORS QUERY
← ▼▲▶

QUERY
8:04 02-02-2022 Wed
E2 Main control and wired control transmission error
← ▼▲▶

TEMP QUERY	
SELECT ADDRESS	◀ 11 ▶
INLET WATER TEMP	25 °C
OUTLET WATER TEMP	25 °C
TOTAL OUTWATER TEMP	25 °C
AMBIENT TEMP	25 °C
← 1/2 ▼▲▶	

9.13 Timer

A daily or weekly schedule can be set.

If the unit is controlled via remote ON-OFF or via Modbus, the timers are disabled.

TEMP QUERY	
INLET BPHE TEMP	25 °C
← 2/2 ▼▲▶	

Menu
MODE
USER MENU
SERVICE MENU
PROJECT MENU
← ▼▲▶

USER MENU
QUERY
TIMER
GENERAL SETTING
DOUBLE SETPOINT
← ▼▲▶

TIMER	
DAILY TIMER	
WEEKLY SCHEDULE	
←	▼▲▶

MONDAY TIMER	
TIMER	◀1▶
ACT	◀OFF▶
TIME ON	◀10:00▶
TIME OFF	◀12:00▶
MODE	◀HEAT▶
←	1/2 ▼▲▶

TIMER	
DAILY TIMER(DISALBE)	
WEEKLY SCHEDULE(DISALBE)	
←	▼▲▶

MONDAY TIMER	
TWS	◀ 40 ▶ °C
SILENT MODE	◀ NIGHT SILENT1 ▶
←	2/2 ▼▲▶

DAILY TIMER	
TIMER	◀1▶
ACT	◀OFF▶
TIME ON	◀10:00▶
TIME OFF	◀12:00▶
MODE	◀HEAT▶
←	1/2 ▼▲▶

DAILY TIMER	
TWS	◀ 40 ▶ °C
SILENT MODE	◀ NIGHT SILENT1 ▶
←	2/2 ▼▲▶

DAILY TIMER	
Timer1 is useless. The start time is same to the end time	
←	▼▲▶

WEEKLY SCHEDULE	
WEEKLY SCHEDULE	◀ MON ▶
WEEKLY SWITCH	◀ ON ▶
←	▼▲▶

9.14 Unit statuses

Code	Description
0.xx	unit address
1.xx	high pressure
2.xx	number of units
3.xx	T4 correction
4.xx	Mode (8: Off; 0: Standby; 1: Cooling; 2: Heating)
5.xx	fan speed 1
6.xx	fan speed 2
7.xx	T3: coil temperature
8.xx	T4: outdoor temperature
9.xx	T5: DHW temperature
10.xx	Taf1: exchanger outlet temperature, antifreeze protection
11.xx	Taf2: exchanger outlet temperature, antifreeze protection
12.xx	Tw: common outlet water temperature, after the last unit
t.xx	Twi water inlet
14.xx	Two outlet water
15.xx	Tz total outlet water
16.xx	THeatR recovery
17.xx	supply 1
18.xx	supply 2
19.xx	Radiation fin temperature 1
20.xx	Radiation fin temperature 2
21.xx	saturated drain temperature (+25)
22.xx	Compressor current A
23.xx	Compressor current B
24.xx	Pump current
25.xx	electronic expansion valve opening A (/20)
26.xx	electronic expansion valve opening B (/20)
27.xx	electronic expansion valve opening C (/4)
28.xx	high pressure
L.xx	low pressure

Code	Description
30.xx	overheating
31.xx	suction temperature
32.xx	silent
33.xx	static pressure
34.xx	DC voltage A (reserved)
35.xx	DC voltage B (reserved)
36.xx	frequency limit (0 = None; 1 = T4; 2 = pressure; 3 = discharge; 4 = low pressure ratio; 5 = Real-time; 6 = Current frequency; 7 = voltage; 8 = Adjustment of energy requirement of pressure ratio; 9 = low pressure in cooling mode)
37.xx	defrosting status (1st digit: T4 selection solution; 2nd digit: at intervals; 3rd and 4th digits: defrosting on timer)
38.xx	EPROM error: 1: Error; 0: No error
39.xx	defrosting
40.xx	initial frequency
41.xx	Tc: Saturation temperature corresponding to high pressure in heating mode
42.xx	Te: Saturation temperature corresponding to low pressure in cooling mode
43.xx	T6a: exchanger inlet temperature
44.xx	T6b: exchanger outlet temperature
45.xx	software version
46.xx	last error
47.xx	----

9.15 Alarms

Code	Description
E2	communication error between main board and keypad
E3	“total” water outlet temperature probe Tw failure - (only for master unit)
E4	water outlet temperature probe Two failure
1E5	condenser temperature probe T3A failure
2E5	condenser temperature probe T3B failure
E6	tank temperature probe T5 failure
E7	environment temperature probe T4 failure
E8	phase sequence / refrigerant leak sensor (if present*)
E9	no flow (manual reset)
2E9	outlet water system
1Eb	antifreeze probe Taf1 failure
2Eb	antifreeze probe Taf2 failure
EC	reduced number of Slave units
Ed	compressor discharge temperature probe failure
1EE	refrigerant temperature probe T6A failure
2EE	refrigerant temperature probe T6B failure
EF	water inlet temperature probe Twi failure
EP	high discharge temperature
EU	total condenser temperature probe Tz failure
P0	high pressure / discharge temperature
P1	low pressure
P2	total condenser output high temperature Tz
P3	over-temperature T4 protection in cooling mode
P4	compressor A in protection
P5	compressor B in protection
P7	condenser high temperature
P9	inlet/outlet water temperature difference
PA	Reserved
Pb	antifreeze protection
1Pb	electric heating antifreeze protection insufficient
2Pb	electric heating antifreeze protection severely insufficient
PC	evaporator low pressure in cooling mode
PE	antifreeze protection evaporator low temperature in cooling mode
PH	over-temperature T4 protection in heating mode
PL	Tfin module, high temperature
1PU	fan A module

Code	Description
2PU	fan B module
H5	High / low voltage
1H9	driver compressor A - configuration error
2H9	driver compressor B - configuration error
1HE	valve A error
2HE	valve B error
3HE	valve C error
1F0	IPM module A communication error
2F0	IPM module B communication error
F2	insufficient overheating
1F4	module A protection L0 or L1 intervention 3 times in 60 minutes
2F4	module B protection L0 or L1 intervention 3 times in 60 minutes
1F6	compressor A bus voltage (PTC)
2F6	compressor B bus voltage (PTC)
Fb	pressure sensor failure
Fd	suction temperature sensor failure
FE	backup pump master-slave DIP switch configuration error
1FF	fan A failure
2FF	fan B failure
3FF	fan C failure
FP	DIP switch for modular unit configuration error
C0	circuit model configuration error
C1	X2Y2E communication error
C2	type of units in cascade not matching
C7	3 times PL
dF	unit in defrost mode
1L0	module A protection
2L0	module B protection
1L1	module A low voltage
2L1	module B low voltage
1L2	module A high voltage
2L2	module B high voltage
1L3	module A hardware error
2L3	module B hardware error
1L4	module A MCE error
2L4	module B MCE error
1L5	module A speed 0

Code	Description
2L5	module B speed 0
1L7	module A no phase
2L7	module B no phase
1L8	module A variation of frequency higher than 15Hz
2L8	module B variation of frequency higher than 15Hz
1L9	module A difference of phase frequency higher than 15Hz
2L9	module B difference of phase frequency higher than 15Hz
1LA	module A high pressure
2LA	module B high pressure
1Ln	module A PFC error
2Ln	module B PFC error
1Lb	Reserved
2Lb	Reserved

* See chapter:

11.18 Refrigerant leak detector

10. R32 gas safety warnings

10.1 Area checks

Before working on systems containing flammable refrigerants, perform safety checks to reduce the risk of combustion to the minimum. Before performing any reparation operations on the cooling system, comply with the following warnings.

10.2 Work procedures

Operations must be performed following a controlled procedure so as to reduce the risk of flammable gases or vapours developing.

10.3 General work area

All the personnel in charge with maintenance operations and other operators working in the local area must be instructed and monitored as regards the nature of the intervention.

Avoid working in tight spaces. The area surrounding the working space must be cordoned off. Make sure the area is secured by monitoring the flammable material.

10.4 Check the presence of refrigerant

Both before and during operations, the area must be monitored with a dedicated refrigerant detector to make sure the technician is aware of the presence of potentially-flammable environments.

Make sure the leak detection equipment is suitable for use with flammable refrigerants and therefore without sparks, suitably sealed or intrinsically safe.

10.5 Presence of the fire extinguisher

If hot interventions are not performed on cooling equipment or connected components, suitable fire fighting equipment must be kept at hand.

Keep a dry-powder or CO₂ extinguisher near the loading area.

10.6 No ignition source

It is absolutely forbidden to use ignition sources that may lead to fire or explosion during operations on the cooling system or on pipes that contain or have contained flammable refrigerant.

All possible ignition sources, including cigarettes, must be kept sufficiently away from the installation, reparation, removal and disposal site as flammable refrigerant may be released in the surrounding area.

Before starting operations, the area surrounding the equipment must be inspected to guarantee the absence of flammables or combustion risks. "SMOKING IS FORBIDDEN" signs must be affixed.

10.7 Ventilated area

Before intervening on the system or performing any hot intervention, make sure to be in an outdoor or suitably ventilated area.

Ventilation must be maintained during operations. Ventilation must disperse the released refrigerant safely,

preferably outdoors in the atmosphere.

10.8 Cooling equipment checks

Should a replacement be necessary, the new components installed must be suitable for the purpose envisaged and compliant with specifications.

Always follow the manufacturer guidelines on maintenance and assistance. In case of doubt, contact the manufacturer technical office for assistance.

The following checks must be performed on systems containing flammable refrigerants:

- the quantity of the charge must comply with the size of the room where the parts containing refrigerant are installed;
- the machine and ventilation intake function correctly and are not obstructed;
- If an indirect cooling circuit is used, the secondary circuits must be checked to verify the presence of refrigerants; the marking on the equipment remains visible and readable;
- Make sure markings and symbols are always readable; cooling pipes or components must be installed in a position that makes improbable their exposure to substances that may corrode the components containing refrigerant, unless they are manufactured with material intrinsically resistant to corrosion or suitably protected against corrosion.

10.9 Electrical device checks

The reparation and maintenance of electric components must include initial safety checks and component inspection procedures.

In case of a fault that compromises safety, do not perform any electrical connection to the circuit until said fault is suitably resolved.

If it is not possible to repair the fault immediately and electrical components need to remain functioning, a temporary solution must be adopted. This must be reported to the owner of the equipment so as to keep all parties informed.

Initial safety checks must include:

- that condensers are emptied. This operation must be performed safely to avoid any sparks;
- that electrical components and wiring are not exposed during the charging, recovering or venting phases;
- That the earth conductor is continuous

10.10 Repairing sealed components

- During the reparation operations of sealed components, disconnect all the equipment before removing sealed casings etc. If, during operations, it is absolutely necessary for the equipment to remain connected, a leak detection device must be placed in the most critical point so as to report any potentially-dangerous situation.
- Pay particular attention to what follows to guarantee

that, while intervening on electrical components, the housing is not altered in a way so as to affect the level of protection. This includes damage to cables, an excessive number of connections, terminals not compliance with the original specifications, damage to gaskets, an unsuitable installation of gaskets, etc.

- Make sure the device is installed safely.
- Check that the seals or sealing materials are not altered in such a way that they no longer impede the entry of flammable environments. Spare parts must comply with manufacturer specifications.

Warning

- ▶ **Using silicone sealants may inhibit the effectiveness of a few types of leak detection equipment. It is not necessary to isolate intrinsically safe components before performing operations on them.**

10.11 Reparation of intrinsically safe components

Do not apply permanent inductive or capacitive loads to the circuit without making sure that they do not exceed the admissible voltage and current allowed for equipment in use.

Intrinsically safe components are the only component type on which operations can be performed in a flammable atmosphere. The testing device must show a correct value. Replace components only with the parts specified by the manufacturer.

Following a leak, other parts could lead to the combustion of the refrigerant in the atmosphere.

10.12 Wires

Make sure wires are not subjected to wear, corrosion, excessive pressure or vibration, that there are no sharp edges and that they do not produce other negative effects on the environment. The inspection must also keep into consideration the effects of time or the continuous vibration caused e.g. by compressors or fans.

Detection of flammable refrigerants

Under no circumstance is it possible to use potential ignition sources to search or detect refrigerant leaks.

Do not use halide lights (or any other open flame detectors).

10.13 Leak detection methods

The following leak detection methods are considered acceptable for systems containing flammable refrigerants. Electric leak detectors must always be used to identify flammable refrigerants, although they do not present a suitable sensitivity level or require recalibration (detection equipment must be calibrated in an area free from refrigerants).

Check that the detector is not a possible source of ignition and that it is suitable for the refrigerant. Leak detection equipment must always be set to an LFL percentage and calibrated depending on the refrigerant used, so the correct gas percentage (25% max) must be verified.

Leak detection fluids are suitable for most refrigerants, although using detergents containing chlorine should be

avoided as this substance may react with the refrigerant and corrode copper pipes.

If a leak is suspected, all open flames must be removed or switched off.

If a leak is identified that requires brazing, all the refrigerant must be recovered from the system or isolated (using interception valves) in a section of the system far away from the leak. Oxygen-Free-Nitrogen (OFN) is then purged through the system both before and during the brazing procedure.

10.14 Removal and evacuation

When intervening on the cooling circuit to perform repair work or any other type of work, always follow the normal procedure. However, considering the risk of flammability, we recommend following the best practices. Comply with the following procedure:

- remove the refrigerant;
- purge the circuit with inert gas;
- evacuate;
- Purge again with inert gas;
- Interrupt the circuit with interruption or brazing.

The refrigerant charge must be collected in suitable recovery tanks. To make the unit safe, flushing with Oxygen-free-Nitrogen must be performed. This procedure may have to be repeated multiple times. Do not use compressed air or oxygen for this operation.

Flushing is obtained interrupting the system vacuum with OFN and filling until the operating pressure is obtained, then releasing into the atmosphere and restoring the vacuum. This process must be repeated until there is no trace of refrigerant in the system.

When using the final OFN charge, the system must be vented to the atmospheric pressure to allow the intervention. This step is essential to perform brazing operations on the pipes.

Make sure that the vacuum pump intake is not near ignition sources and that there is suitable ventilation.

10.15 Charging operations

In addition to conventional charging operations, the following requirements must be complied with:

- When using charging equipment, make sure that the various refrigerants are not contaminated. Flexible tubes or conduits must be as short as possible to reduce to the minimum the quantity of refrigerant contained.
- Tanks must be kept in a vertical position.
- Before loading the system with refrigerant, check that the cooling system is earthed.
- Label the system when fully charged (unless already labelled).
- Make sure not to fill the cooling system excessively.
- Before recharging the system, the pressure must be tested with OFN. A leak test must be performed after the charging operations but before commissioning. Before leaving the site, perform an additional leak test.

10.16 Dismantling

Before performing this procedure, it is essential that the technician has become familiar with the equipment and the relative details.

We recommend employing good practices for a safe recovery of the refrigerants.

Before performing the operation, take a sample of oil and refrigerant should an analysis be necessary before reusing the regenerated refrigerant. Before performing the operation, check the availability of electricity.

- Become familiar with the equipment and how it functions.
- Electrically isolate the system.

Before attempting the procedure, check that:

- The mechanical manipulation equipment is available, if necessary, to handle refrigerant tanks;
- All the personal protection equipment is available and employed correctly;
- The recovery procedure is monitored at all times by skilled personnel;
- The recovery equipment and tanks comply with suitable standards.
- If possible, pump the cooling system.
- If it is not possible to obtain a vacuum, make sure that a collector removes the refrigerant from various parts of the system.
- Before proceeding with the recovery, check that the tank is located on the scales.
- Start up the recovery machine and use it following the instructions by the manufacturer.
- Do not fill the tanks excessively. (Do not exceed 80% of the liquid volume).
- Do not exceed the tank's maximum operating pressure, not even momentarily.
- Once the tanks are filled correctly and the process is over, make sure that the tanks and equipment are immediately removed from the site and that all insulation valves on the equipment are closed.
- The refrigerant recovered must not be loaded into another cooling system unless it has been cleaned and checked.

10.17 Labelling

Equipment must be labelled reporting the dismantling and emptying of the refrigerant.

Labels must be dated and signed.

Make sure all the equipment is labelled and reporting the presence of flammable refrigerant.

10.18 Recovery

When removing the refrigerant from the system, please adopt good practices to remove all refrigerants safely in case of both assistance or decommissioning operations.

When transferring the refrigerant into the tanks, make sure only suitable tanks are used to recover the refrigerant.

Make sure enough tanks are used.

All the tanks to be used are designated for the recovered refrigerant and are labelled for that specific refrigerant (e.g. special tanks for refrigerant collection).

Tanks must be equipped with a perfectly-functioning safety valve and relative interception valves.

Empty recovery tanks are evacuated and, if possible, cooled before recovery.

Recovery equipment must be perfectly functioning with the respective instruction booklets at hand and they must be suitable to recover flammable refrigerants. A series of perfectly-functioning calibrated scales must also be available.

Flexible tubes must be equipped with leak-proof disconnection fittings in good condition. Before using the recovery machine, make sure it is in good condition, maintained and that all associated electrical components are sealed to avoid combustion in case of a refrigerant leak. Please contact the manufacturer in case of doubt.

The refrigerant recovered must be taken to the supplier in suitable recovery tanks and with the relative waste transfer note suitably filled in.

Do not mix the refrigerants in the recovery units nor in the tanks.

If it is necessary to remove compressors or compressor oils, make sure they are evacuated to an acceptable level to make sure no trace is left of the flammable refrigerant inside the lubricant. The evacuation process must be performed before taking the compressors back to the suppliers.

The electric resistance must be used with the compressor body only to accelerate this process.

Operations to discharge the oil from the system must be performed in full safety.

10.19 Transport, mark and storage

- 1 Transport of equipment containing flammable refrigerants.
 - Compliance with transport regulations
- 2 Marking of equipment with symbols.
 - Compliance with local regulations
- 3 Disposal of equipment employing flammable refrigerants.
 - Compliance with national regulations
- 4 Storage of equipment/devices.
 - The equipment must be stored in compliance with the instructions provided by the manufacturer.
- 5 Storing packed (unsold) equipment.
 - Packing must be performed in such a way that mechanical damage to the equipment inside it does not cause refrigerant leaks. The maximum number of elements that can be stored together is determined by local regulations.

11. Maintenance

11.1 Safety

Operate in compliance with safety regulations in force.

To carry out the operations use protection devices:

gloves, goggles, helmet, headphones, protective knee pads.



All operations must be carried out by personnel trained on possible risks of a general nature, electrical and deriving from operating with equipment under pressure.

Only qualified personnel can operate on the unit, as required by the regulation in force.

11.2 General

Maintenance must be done by authorized centres or by qualified personnel.

The maintenance allows to:

- maintain the unit efficiency
- increase the life span of the equipment
- assemble information and data to understand the state of the unit efficiency and avoid possible damages

Warning

- ▶ **before checking, please verify the following:**
- ▶ **the electrical power supply line should be isolated at the beginning**
- ▶ **the unit isolator is open, locked and equipped with the suitable warning**
- ▶ **make sure no tension is present**
- ▶ **After turning off the power, wait at least 5 minutes before accessing to the electrical panel or any other electrical component.**
- ▶ **Before accessing check with a multimeter that there are no residual stresses.**

11.3 Inspections frequency

Perform an inspection every 6 months minimum.

The frequency, however, depends on the use.

In the event of frequent use it is recommended to plan inspections at shorter intervals:

- frequent use (continuous or very intermittent use, near the operating limits, etc)
- critical use (service necessary)

Warning

- ▶ **Before performing any work, please read carefully: SAFETY WARNINGS FOR OPERATIONS ON UNITS CONTAINING R32**

ATTENTION

- ▶ **Do not go up to the surface**
- ▶ **Do not place heavy objects.**

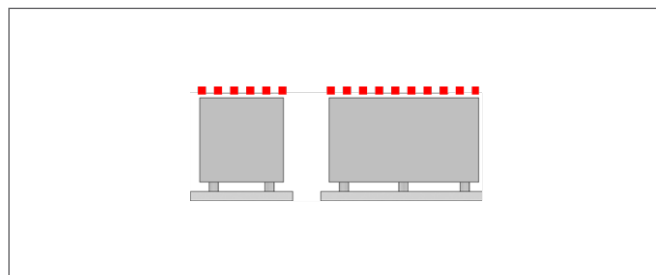

11.4 Unit booklet

It's advisable to create a unit booklet to take notes of the unit interventions.

In this way it will be easier to adequately note the various interventions and aid any troubleshooting.

Report on the booklet:

- date
- intervention description
- carried out measures etc.

11.5 Standby mode

If a long period of inactivity is foreseen:

- turn off the power
- avoid the risk of frost (empty the system or add glycol)
- Turn off the power to avoid electrical risks or damages by lightning strikes.
- With lower temperatures keep heaters turned on in of the electrical panel (option).

It's recommended that the re-start after the stopping period is performed by a qualified technician, especially after seasonal stops or seasonal switching.

When restarting, refer to what is indicated in the "start-up" section.

Schedule technical assistance in advance to avoid hitches and to guarantee that the system can be used when required.

11.6 Recommended periodical checks

intervention frequency (months)		1	6	12
1	presence corrosion			X
2	panel fixing			X
3	fan fixing		X	
4	coil cleaning		X	
5	water filter cleaning		X	
6	water: quality, ph, weight of glycol (%)		X	
7	check the exchanger efficiency	X		
8	circulating pumps			X
9	check of the fixing and the insulation of the power lead			X
10	check of the earthing cable			X
11	electric panel cleaning			X
12	capacity contactor status			X
13	terminals closing, cable insulation integrity			X
14	voltage and phase unbalancing (no load and on-load)			X
15	absorptions of the single electrical loads		X	
16	test of the compressor crankcase heaters		X	
17	Checking for leaks		X	
18	survey of the refrigerant circuit operating parameters			*
19	safety valve		X	
20	protective device test: pressure switches, thermostats, flow switches etc..			*
21	control system test: setpoint, climatic compensations, capacity stepping, water / air flow-rate variations		X	
22	control device test: alarm signalling, thermometers, probes, pressure gauges etc..		X	

Warning

- ***Refer to the local regulations. Companies and technicians performing installation, maintenance/ repair, leak control and recovery operations must be CERTIFIED as set out by the local regulations.**

11.7 System drain

The system must be drained only if necessary.

Do not drain the system periodically; this can lead to corrosion.

- 1 empty the system
- 2 empty the exchanger, use all of the shut-off valves and grub screws present
- 3 blow the exchanger with compressed air
- 4 dry the exchanger with hot air; for greater safety, fill the exchanger with glycol solution
- 5 protect the exchanger from air by filling it with nitrogen
- 6 take the drain caps off the pumps

Any antifreeze liquid contained in the system should not be discharged freely as it is a pollutant. It must be collected and reused.

Before start-up, wash the system.

It's recommended that the re-start after the stopping period is performed by a qualified technician, especially after seasonal stops or seasonal switching.

When restarting, refer to what is indicated in the "start-up" section.

Schedule technical assistance in advance to avoid hitches and to guarantee that the system can be used when required.

11.8 Compressor crankcase heater

Check:

- closing
- Operation

11.9 Water side exchanger

The exchanger must be able to provide the maximum thermal exchange, therefore its inner surfaces must be cleaned from dirt and incrustations.

Check the difference between the outlet water temperature and the evaporation temperature: if the difference is greater than 8°C–10°C, it is advisable to clean the exchanger.

It must be cleaned:

- with circulation opposite to the usual one
- at least 1.5 times faster than the nominal one
- with an appropriate moderately acid product (95% water + 5% phosphoric acid)
- after washing, rinse with water to remove detergent residues

11.10 Water filter

Check that no impurities prevent the correct passage of water.

11.11 Flow Switch

- check operation
- remove incrustations from the blade

11.12 Circulation pumps

Check:

- there are no leaks
- status of the bearings (anomalies are indicated by abnormal noises and vibrations)
- the terminal protection covers are closed and the cable holders are properly positioned

11.13 Insulations

Check the status of the insulations: if necessary, apply glue and renew the seals.

11.14 Pressure relief valve

The pressure relief valve must be replaced:

- if it is activated
- if there is oxidation
- based on the date of manufacture, in accordance with local regulations.

11.15 Structure

- Wash it at least once or twice a year, depending on exposure (pollution, salt deposits, dirt).

Clean with neutral detergent and cold or warm water (max 30°C).

Do not use solvents or acid, alkaline, abrasive products.

- Check the condition of the parts making up the structure.

Treat those parts of the unit subject to oxidation, with paints act at eliminating or reducing the oxidation phenomena.

- Check fastening of the unit external panelling.

Bad fastening give rise to anomalous noises and vibrations.

11.16 Air side exchanger

- ▶ **Accidental contact with the exchanger fins can cause cutting injuries: use protective gloves.**

The coil must give the maximum thermal exchange, therefore its surface must be cleaned from dirt and incrustations.

Clean at least every three months.

The cleaning frequency must be increased according to the build-up of dirt/dust and the environment (e.g. coastal areas with chlorides and salts or industrial areas with aggressive substances).

Clean the air inlet side.

Keep the direction parallel to the fins to avoid damage.

Check that the aluminium fins are not bent or damaged, in the event of damages contact the authorised service centre which will "comb" the coil to restore optimal air flow

Shut down periods

During periods when the unit is not used for more than a

week, the coil must be completely cleaned following the cleaning procedure.

Cleaning procedure

Compared to tube and fin heat exchangers, these coils tend to accumulate more dirt on the outer surface and less on the inside, making them easier to clean.

Follow the steps below for proper cleaning.

Remove surface debris

Remove surface dirt, leaves, fibres, etc. with a vacuum dirt exhaustor (preferably using a brush or other soft accessory rather than a metal hose), compressed air blown from the inside and/or a soft bristle brush. Do not bump or scrape the coil.

Rinse

Rinse with water only. Do not use chemicals to clean heat exchangers with microchannels as they may cause corrosion.

Wash gently, preferably from the inside out and from the top down, running water through each fin passage until it comes out clean. Microchannel fins are more resistant than traditional coils, but they must still be handled with care.

Do not use a steam cleaner as it could cause damage. Warranty claims relating to cleaning damages, particularly from steam cleaners or corrosion from chemical coil detergents, will NOT be accepted

Blow dry

Microchannel exchangers could retain more water than traditional coils. Drain or vacuum residual water to speed up drying and prevent clogging.

ATTENTION

- ▶ **Field applied coatings are not recommended for brazed aluminum MicroChannel heat exchangers.**

11.17 Electric fans

Check:

- ensure that the fan and its protection grilles are fixed properly
- the fan bearings (anomalies are indicated by abnormal noise and vibrations)
- the terminal protection covers are closed and the cable holders are properly positioned

11.18 Refrigerant leak detector

Option

When leak detector is present it is in series to the phase sequence detector.

- ▶ **The E8 alarm referred to the leak detector is detected if there is a refrigerant leakage.**

However, anytime there is the leak detector installed in the unit, at startup the unit detects E8 in the first 4 minutes to initialize.

After 4 minutes the alarm disappears automatically.

Refer to the component manufacturer's manual for

specific information.

11.18.1 Maintenance

The inspection must be carried out by qualified servicing personnel.

- Check correct operation of the LEDs.
- Check correct operation of the buzzer and relay.
- Check signal transmission to the BMS / central controller, if connected.
- Calibrate the sensor or contact the manufacturer to exchange the sensor with a factory-calibrated one.

Sensors have an average life of 2 to 5 years, depending on the type, after which they must be replaced.

- ▶ **Sensors must be checked after exposure to significant gas concentrations, which can reduce the duration of the sensor and/or reduce its sensitivity.**

12. Anti-vibration mounts

12.1 Anti-vibration mount support

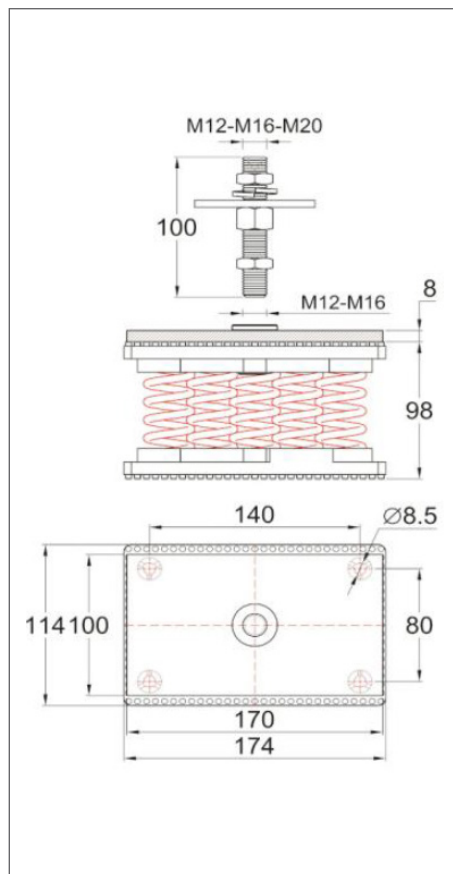
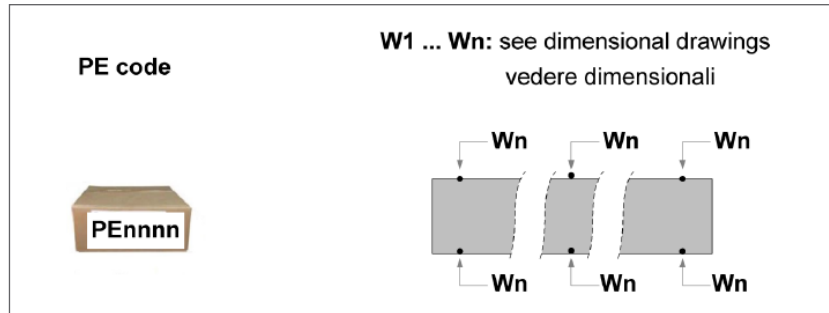

PLURIMOLLA	W1	W2	W3	W4	W5	W6
PEI400006	RZ603-105	RZ605-108	RZ605-108	RZ603-105	-	-
PEI400008	RX503-201	RX503-201	RX503-201	RX503-201	-	-
PEI400019	RX503-201	RX503-201	RX503-201	RX503-201	RX503-201	RX503-201

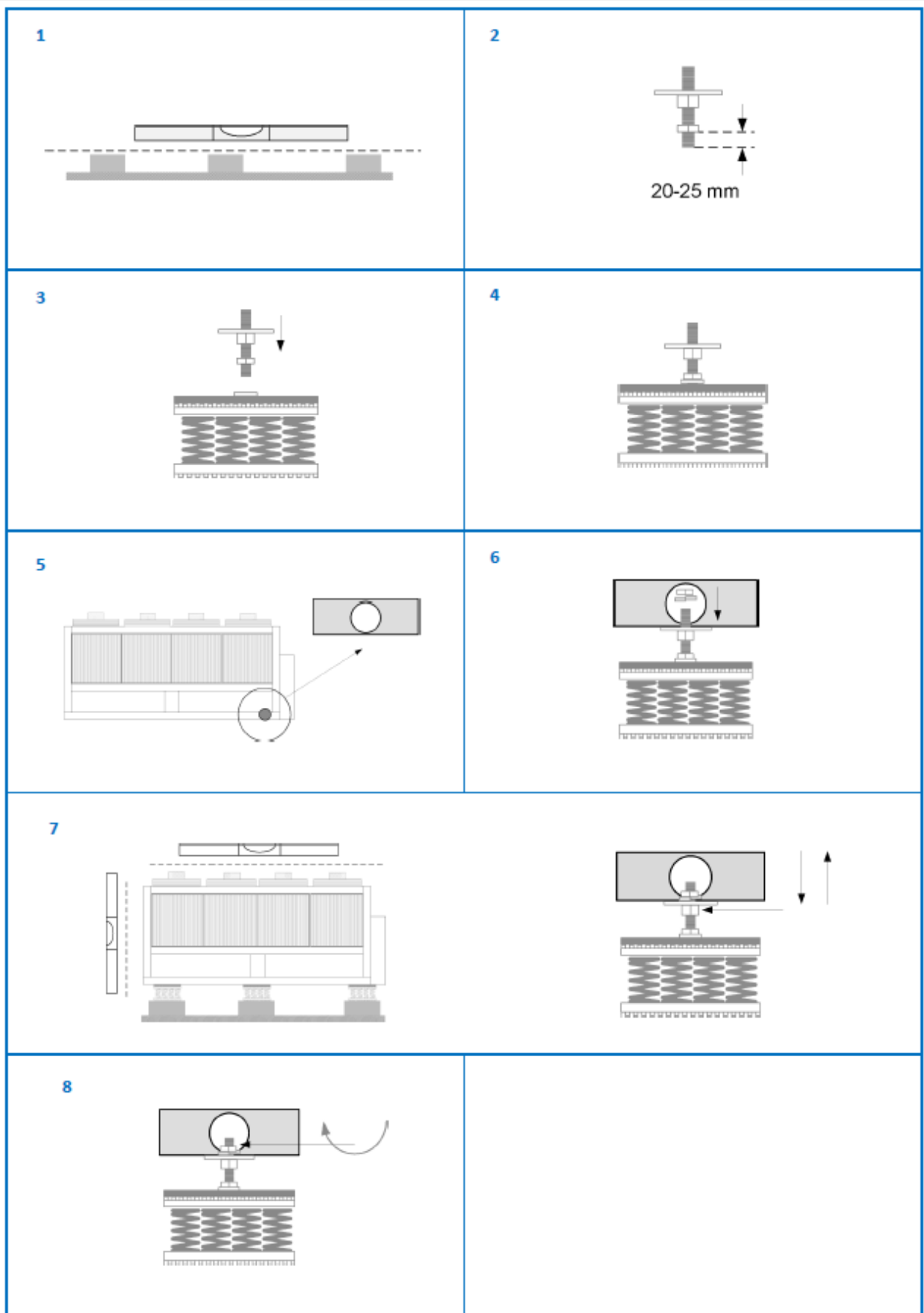

12.2 Anti-seismic anti-vibration mounts

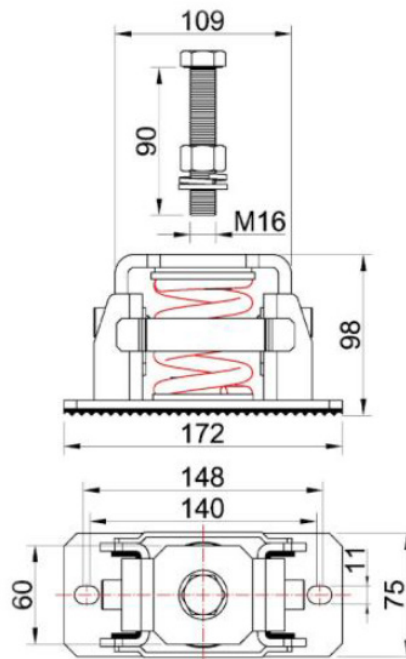
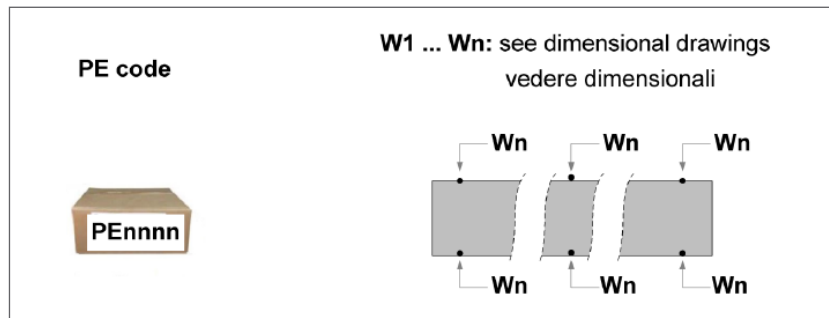

ANTISISMICO	W1	W2	W3	W4	W5	W6
PEI400009	LaLrVr 31	LaLrVr 501	LaLrVr 501	LaLrVr 31	-	-
PEI400011	LaLV 53	LaLV 53	LaLV 53	LaLV 53	-	-
PEI400020	LaLV 53	LaLV 53	LaLV 53	LaLV 53	LaLV 53	LaLV 53

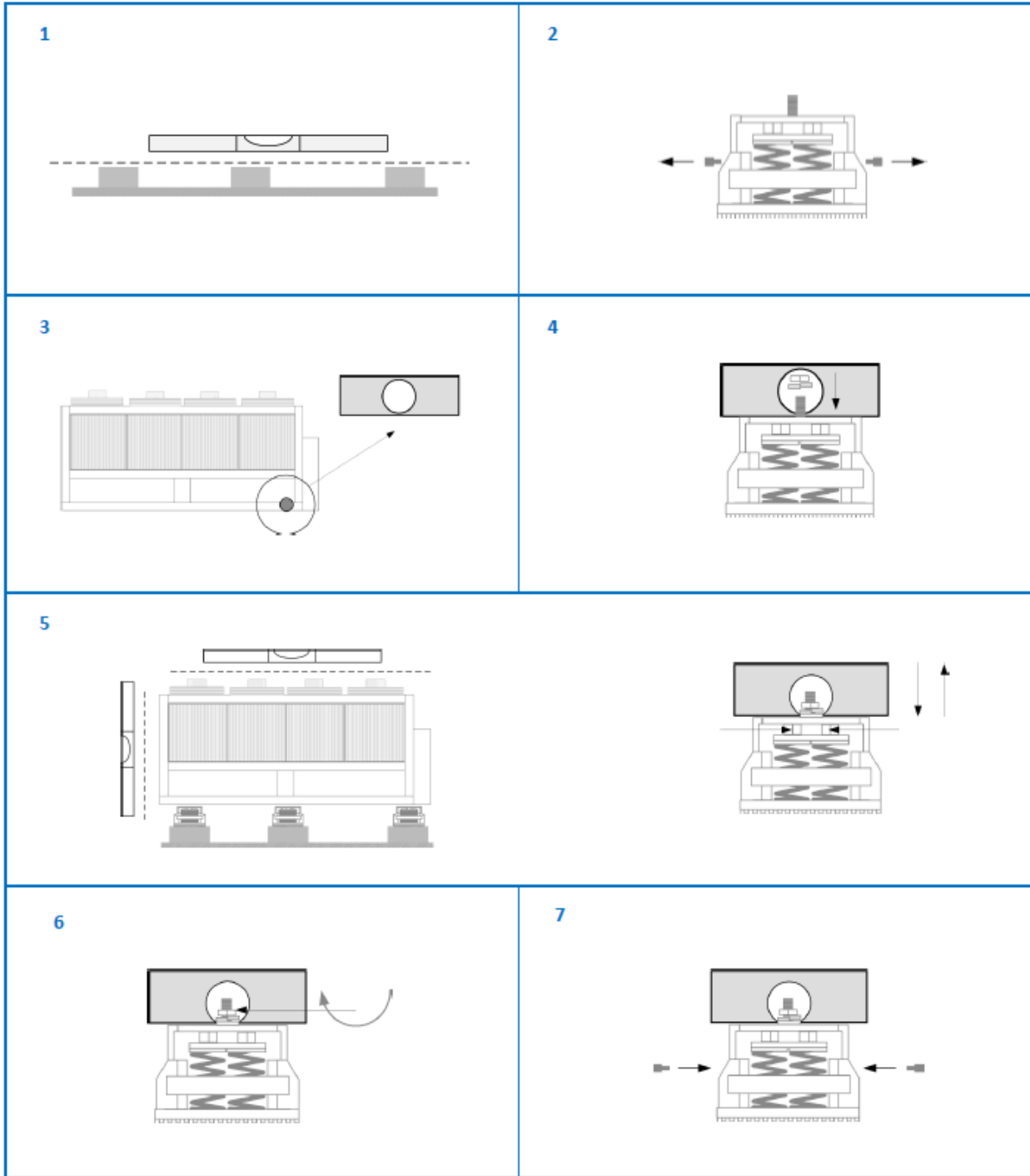

13. Decommissioning

13.1 Disconnection

Warning

- ▶ **Before performing any work, carefully read: SAFETY WARNINGS FOR OPERATIONS ON UNITS CONTAINING R32**

Avoid leak or spills into the environment.

Before disconnecting the unit, the following must be recovered, if present:

- refrigerant gas
- Anti-freeze solutions in the hydraulic circuit

Awaiting decommissioning and disposal, the unit can also be stored outdoors, as bad weather and rapid changes in temperature do not harm the environment provided that the electric, cooling and hydraulic circuits of the unit are intact and closed.

13.2 WEEE INFORMATION

The manufacturer is registered on the EEE National Register, in compliance with implementation of Directive 2012/19/EU and relevant national regulations on waste electrical and electronic equipment.

This Directive requires electrical and electronic equipment to be disposed of properly.

Equipment bearing the crossed-out wheelee bin mark must be disposed of separately at the end of its life cycle to prevent damage to human health and to the environment.

Electrical and electronic equipment must be disposed of together with all of its parts.

To dispose of “household” electrical and electronic equipment, the manufacturer recommends you contact an authorised dealer or an authorised ecological area.

“Professional” electrical and electronic equipment must be disposed of by authorised personnel through established waste disposal authorities around the country.

In this regard, here is the definition of household WEEE and professional WEEE:

WEEE from private households: WEEE originating from private households and WEEE which comes from commercial, industrial, institutional and other sources which, because of its nature and quantity, is similar to that from private households. Subject to the nature and quantity, where the waste from EEE was likely to have been by both a private household and users of other than private households, it will be classed as private household WEEE;

Professional WEEE: all WEEE which comes from users other than private households.

This equipment may contain:

- refrigerant gas, the entire contents of which must be recovered in suitable containers by specialised personnel with the necessary qualifications;
- lubrication oil contained in compressors and in the

cooling circuit to be collected;

- mixtures with antifreeze in the water circuit, the contents of which are to be collected;
- mechanical and electrical parts to be separated and disposed of as authorised.

When machine components to be replaced for maintenance purposes are removed or when the entire unit reaches the end of its life and needs to be removed from the installation, waste should be separated by its nature and disposed of by authorised personnel at existing collection centres.



14. Residual risks

14.1 General

In this section the most common situations are indicated, as these cannot be controlled by the manufacturer and could be a source of risk situations for people or things.

Danger zone

This is an area in which only an authorised operator may work.

The danger zone is the area inside the unit which is accessible only with the deliberate removal of protections or parts thereof.

14.2 Handling

The handling operations, if implemented without all of the protection necessary and without due caution, may cause the drop or the tipping of the unit with the consequent damage, even serious, to persons, things or the unit itself.

Handle the unit following the instructions provided in the present manual re-garding the packaging and in compliance with the local regulations in force.

Should the refrigerant leak please refer to the refrigerant "Safety sheet".

14.3 Installation

The incorrect installation of the unit could cause water leaks, condensate accumulation, leaking of the refrigerant, electric shock, poor operation or damage to the unit itself.

Check that the installation has been implemented by qualified technical personnel only and that the instructions contained in the present manual and the local regulations in force have been adhered to.

The installation of the unit in a place where even infrequent leaks of inflammable gas and the accumulation of this gas in the area surrounding the area occur could cause explosions or fires.

Carefully check the positioning of the unit.

The installation of the unit in a place unsuited to support its weight and/or guarantee adequate anchorage may result in consequent damage to things, people or the unit itself.

Carefully check the positioning and the anchoring of the unit.

Easy access to the unit by children, unauthorised persons or animals may be the source of accidents, some serious.

Install the unit in areas which are only accessible to authorised person and/or provide protection against intrusion into the danger zone.

14.4 General risks

Smell of burning, smoke or other signals of serious anomalies may indicate a situation which could cause damage to people, things or the unit itself.

Electrically isolate the unit (yellow-red isolator).

Contact the authorised service centre to identify and resolve the problem at the source of the anomaly.

Accidental contact with exchange batteries, compressors, air delivery tubes or other components may cause injuries and/or burns.

Always wear suitable clothing including protective gloves to work inside the danger zone.

Maintenance and repair operations carried out by non-qualified personnel may cause damage to persons, things or the unit itself.

Always contact the qualified assistance centre.

Failing to close the unit panels or failure to check the correct tightening of all of the panelling fixing screws may cause damage to persons, things or the unit itself.

Periodically check that all of the panels are correctly closed and fixed.

If there is a fire the temperature of the refrigerant could reach values that increase the pressure to beyond the safety valve with the consequent possible projection of the refrigerant itself or explosion of the circuit parts that remain isolated by the closure of the tap.

Do not remain in the vicinity of the safety valve and never leave the refrigerating system taps closed.

14.5 Electric parts

An incomplete attachment line to the electric network or with incorrectly sized cables and/or unsuitable protective devices can cause electric shocks, intoxication, damage to the unit or fires.

Carry out all of the work on the electric system referring to the electric layout and the present manual ensuring the use of a system thereto dedicated.

An incorrect fixing of the electric components cover may lead to the entry of dust, water etc inside and may consequently electric shocks, damage to the unit or fires.

Always fix the unit cover properly.

When the metallic mass of the unit is under voltage and is not correctly connected to the earthing system it may be as source of electric shock and electrocution.

Always pay particular attention to the implementation of the earthing system connections.

Contact with parts under voltage accessible inside the unit after the removal of the guards can cause electric shocks, burns and electrocution.

Open and padlock the general isolator prior to removing the guards and signal work in progress with the appropriate sign.

Contact with parts that could be under voltage due to the start up of the unit may cause electric shocks, burns and electrocution.

When voltage is necessary for the circuit open the

isolator on the attachment line of the unit itself, padlock it and display the appropriate warning sign.

14.6 Moving parts

Contact with the transmissions or with the fan aspiration can cause injuries.

Prior to entering the inside of the unit open the isolater situated on the con-nection line of the unit itself, padlock it and display the appropriate warning sign.

Contact with the fans can cause injury.

Prior to removing the protective grill or the fans, open the isolator on the attachment line of the unit itself, padlock it and display the appropriate warning sign.

14.7 Refrigerant

The intervention of the safety valve and the consequent expulsion of the gas refrigerant may cause injuries and intoxication.

Always wear suitable clothing including protective gloves and eyeglasses for operations inside the danger zone.

Should the refrigerant leak please refer to the refrigerant "Safety sheet".

Contact between open flames or heat sources with the refrigerant or the heating of the gas circuit under pressure (e.g. during welding operations) may cause explosions or fires.

Do not place any heat source inside the danger zone.

The maintenance or repair interventions which include welding must be carried out with the system off.

14.8 Hydraulic parts

Defects in tubing, the attachments or the removal parts may cause a leak or water projection with the consequent damages to people, things or shortcircuit the unit.

15. Unit in modular configuration

Maximum number of connectable units: **8**

The system is completely controlled by the Master unit.

Each module can be equipped with an inertial system storage tank.

Each unit with DHW option must have its own DHW tank.

An external pumping group sized for the entire capacity of the modular system must be provided (by the Customer). The pumping group will be managed by the Master unit through a dry contact and 0-10V signal.

Modular configuration is also available with cooling only units, but not with heat pumps.

15.1 Control logic

In a cascade system, Tw (supply water flow temperature for the entire system) and TWS (set point temperature) are measured by the master unit.

The master unit will periodically (standard time 80 seconds) evaluate the current load based on the outlet water temperature, the set point distance and speed difference of the water temperature.

Depending on evaluation of the load performed by the master unit, the number of units running will either be kept stable, increased or reduced.

Once it is switched on, a unit will continue to operate according to its own logic (T4, water temperature, etc.).

15.2 Tw control probe

The TW probe must be installed on the supply line of the unit, as far away as possible.

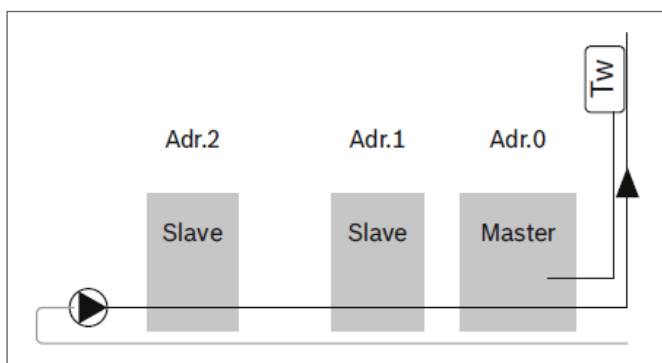

15.3 Electrical connections

All units must be electrically connected to each other via the X-Y-E BUS.

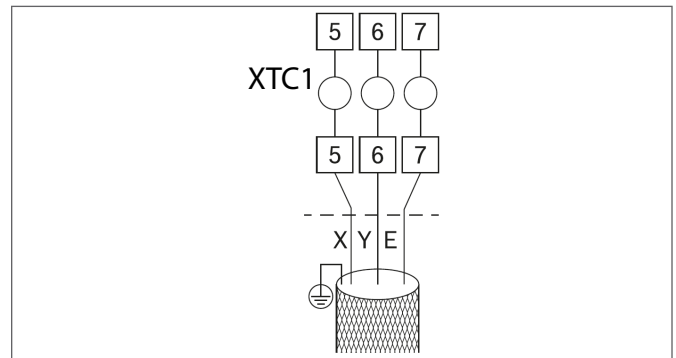

The TW outlet water temperature control probe, the flow switch and the backup electric heater must be controlled by the master unit.

15.4 System with reversed return connection

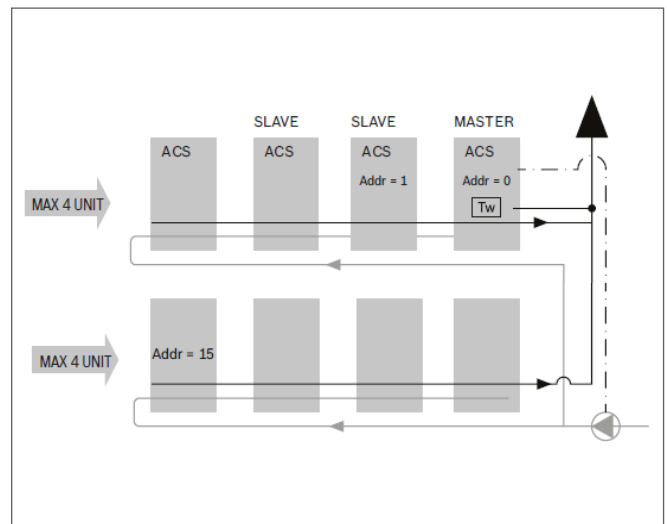

15.5 Single/multiple pump system

Configure DIP switch S12-2 according to the type of system.

15.5.1 Single water pump

A check valve is not required in this configuration.

Pump control is only enabled on the master unit

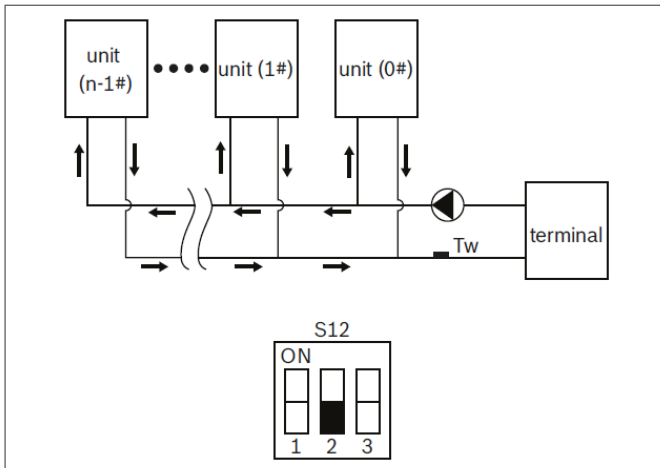

15.5.2 Multiple water pumps

A check valve is required for each unit in this configuration.

Pump control is enabled on each unit

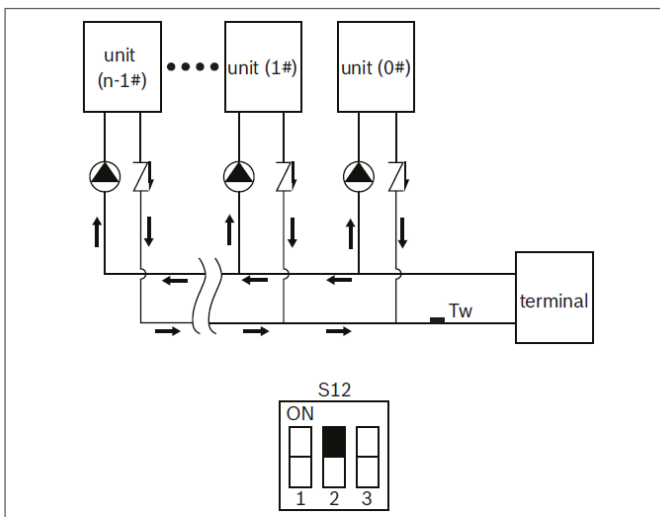

15.6 Addressing

The maximum number of units connected can be 8.

Modular configuration involves two networks:

- the network of the controllers
- the network of the units (main boards).

Each network has its own master, which must have address = 0.

All the units have 2 address, with one for the main board and one for the slave board in the unit. The units must therefore be set with the following addresses:

- Master unit has address 0 (master board) + address 2 (slave board)
- Slave unit 1 has address 2 (master board) + address 3 (slave board)
-
- Slave unit 8 has address 14 (master board) + address 15 (slave board).

Set the correct date and time on each unit before connecting them to the network.

Enable multiple configuration on each unit:

SW12-2 : It1

- ON units in multiple configuration
- OFF single unit

Addressing units

Units are addressed using encoder ENC4 on the back of the board.

The address is the number on the encoder.

The address is shown on display DSP1.

E.g.:

MASTER : address = 0 encoder = 0

SLAVE 1 : address = 2 encoder = 2

The address of the unit is shown on display "DSP1" on the main board.

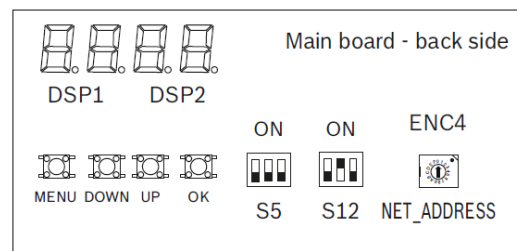

15.6.1 Addressing controls

Up to 8 controls can be addressed, for example:

- 8 units with relative controller on board, one of which is the master
- 7 units with relative controller on board + 1 remote controllers as the master.

The controls must have an address comprising an even number between 0 and 15.

Press ▼▲ to select SETTING ADDRESS.

Press ◀ or ▶ to set the address

Press OK to confirm

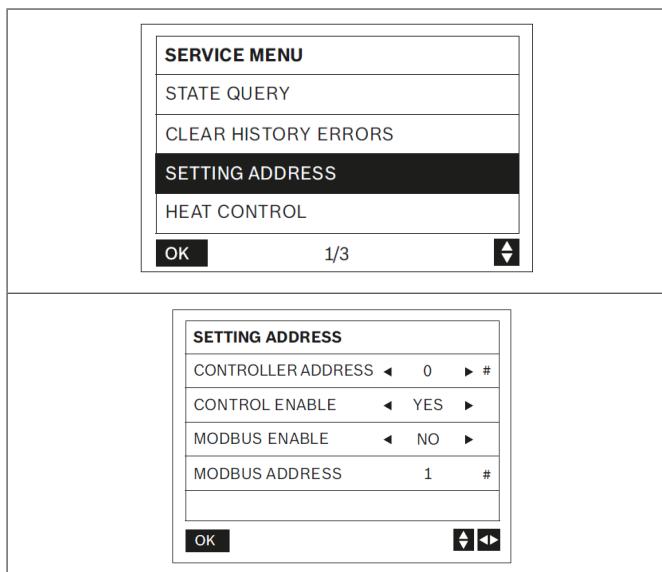

15.7 Remote ON-OFF

With the units in modular configuration, remote control must be applied to the master unit, which transmits it to the slave units.

15.8 Start-up

Complete system management is carried out by the master unit, identified by address 0.

Thermoregulation takes place on the supply temperature of the entire system (T_w).

At switch-on, when a load is requested, the units are switched on in sequence based on their address, in numerical order.

When the load decreases, the units are switched off following the same sequence.

Example in cooling mode:

If $T_w \geq \text{set point} + 10^\circ\text{C}$

- the control activates 50% of the resources in sequence based on the set address.
- after a time interval (default: 240 seconds)
- if the load increases, additional resources are activated
- if the load decreases, the units are switched off following the same sequence (first start, first stop).

If $T_w < \text{set point} + 10^\circ\text{C}$ (in cooling mode)

- the control activates only the master unit.
- after a time interval (default: 240 seconds)
- if the load increases, additional resources are activated based on the set address
- if the load decreases, the master unit switches off.

15.9 Alarms

In the event of an alarm on one of the system units, there could be different outcomes:

- in the event of an alarm on a slave unit, the other system units will continue to operate
- in the event of an alarm on a master unit and the system is multi-pump (one pump per unit, set S12-2 ON) the slave units will continue to operate
- in the event of an alarm on a master unit and the system is with single pump (dial S12-2 OFF) the whole system will stop.

16. Modbus

16.1 Communication specifications: RS - 485

Protocol	ModbusRTU: 9600, 8, N,1
Transmission speed	9600pbs
Data bit	8 data bits
Parity bit	None parity
Stop bit	1 stop bit

Connections

Connect on the back of the controller.

Modular unit: connect the Modbus to the master unit port.

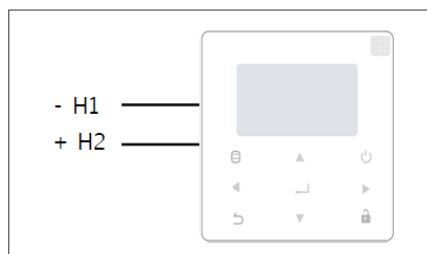

Enabling

SERVICE MENU → SETTING ADDRESS → Modbus enable → YE

Reg	Data Type	R/W	Name	Description
Reg	Data Type	R/W	Name	Description
0	S16	R&W	Running mode	Range: HP: 1-Cool, 2-Heat, 4-DHW, 8-OFF , FC/CO: 1-Cool, 8-OFF , Default: 8-OFF , Unit of measurement: - , Notes: DHW mode setting is NOT valid for slave units of multi pump system which uses dedicated item at address 207
1	S16	R&W	Double setpoint temperature Tws 1	Range: CO/FC cooling mode: MAX(-8,Tsafe) ~ 20 , HP cooling mode: 0 ~ 20 , HP heating mode premium series: 25 ~ 55 , HP heating mode excellence series: 25 ~ 60 , Default: CO/FC: 7 , HP cooling mode: 7 , HP heating mode: 35 , Unit of measurement: [°C] , Notes:
2	S16	R&W	Double setpoint temperature Tws 2	Range: CO/FC cooling mode: MAX(-8,Tsafe) ~ 20 , HP cooling mode: 0 ~ 20 , HP heating mode premium series: 25 ~ 55 , HP heating mode excellence series: 25 ~ 60 , Default: CO/FC 10 , HP cooling mode: 10 , HP heating mode: 30 , Unit of measurement: [°C] , Notes:
3	S16	R&W	Offset temperature (OFFSET-C/ OFFSET-H)	Range: Cooling mode 0 ~ 15 , Heating mode: 0 ~ 30 , Default: Cooling mode: 10 , Heating mode: 10 , Unit of measurement: [°C] , Notes:
4	S16	R&W	DHW set temperature - T5S	Range: T5s min ~ T5s max , Default: 50 , Notes: Available only for HP , Unit of measurement: [°C]
5	S16	R&W	Reserved	

Reg	Data Type	R/W	Name	Description
6	S16	R&W	Clear lock errors	Range: 0-Invalid, 1-Clear all the lock errors , Default: 0-Invalid , Unit of measurement: - , Notes:
7	S16	R&W	Snow blowing function	Range: 0 - OFF, 1 - ON , Default: 1 - ON , Unit of measurement: - , Notes:
8	S16	R&W	Out pressure switch setting	Static pressure setting , Range: 0 - static pressure, 1 - low static pressure, 2 - medium static pressure, 3 - high static pressure , Default: 0 - static pressure , Unit of measurement: - , Notes:
9	S16	R&W	Smart grid	Smart grid function enable , Range: 0 - All function disabled, 1 - SG enable, 2 - EVU enable, 3 - SG and EVU enable , Default: 0 - All functions disabled , Unit of measurement: - , Notes:
10 ~ 99			RESERVED	
100	S16	R&W	Silent mode	Range: 1 - Standard, 2 - Silent mode, 3 - Night silent mode, 7 - Super silent mode , Default: 1 - Standard , Unit of measurement: - , Notes:
101	S16	R&W	Double setpoint	Range: 0 - Disable, 1 - Enable , Default: 0 - Disable , Unit of measurement: - , Notes:
102	S16	R&W	Double setpoint temperature Tws 1 in cooling mode	Range: CO/FC : MAX(-8,Tsafe) ~ 20 , HP: 0 ~ 20 , Default: 7 , Unit of measurement: [°C] , Notes:
103	S16	R&W	Double setpoint temperature Tws 2 in cooling mode	Range: CO/FC : MAX(-8,Tsafe) ~ 20 , HP: 0 ~ 20 , Default: 10 , Unit of measurement: [°C] , Notes:
104	S16	R&W	Double setpoint temperature Tws 1 in heating mode	Range: HP premium series: 25 ~ 55 , HP excellence series: 25 ~ 60 , Default: 35 , Unit of measurement: [°C] , Notes:
105	S16	R&W	Double setpoint temperature Tws 2 in heating mode	Range: HP premium series: 25 ~ 55 , HP excellence series: 25 ~ 60 , Default: 30 , Unit of measurement: [°C] , Notes:
106	S16	R&W	Temperature compensation enable in cooling mode	Range: 0 - Disable, 1 - Enable , Default: 0 - Disable , Unit of measurement: - , Notes:
107	S16	R&W	T4 COOL 1	Temperature compensation point 1 in cooling mode , Range: 15 ~ 30 , Default: 25 , Unit of measurement: [°C] , Notes:
108	S16	R&W	T4 COOL 2	Temperature compensation point 2 in cooling mode , Range: 40 ~ 45 , Default: 40 , Unit of measurement: [°C] , Notes:
109	S16	R&W	OFFSET-C	Temperature compensation offset in cooling mode , Range: 0 ~ 15 , Default: 10 , Unit of measurement: [°C] , Notes:
110	S16	R&W	Temperature compensation enable in heating mode	Range: 0 - Disable, 1 - Enable , Default: 0 - Disable , Unit of measurement: - , Notes:
111	S16	R&W	T4 HEAT 1	Temperature compensation point 1 in heating mode , Range: -15 ~ -10 , Default: -10 , Unit of measurement: [°C] , Notes:
112	S16	R&W	T4 HEAT 2	Temperature compensation point 2 in cooling mode , Range: 15 ~ 30 , Default: 15 , Unit of measurement: [°C] , Notes:
113	S16	R&W	OFFSET-H	Temperature compensation offset in cooling mode , Range: 0 ~ 30 , Default: 10 , Unit of measurement: [°C] , Notes:
114	S16	R&W	Heat 2 force on	Range: 0 - No, 1 - Yes , Default: 0 - No , Unit of measurement: - , Notes: Only valid for single pump system

Reg	Data Type	R/W	Name	Description
115	S16	R&W	DHW enable	Range: 0 - Disable, 1 - Enable , Default: 0 - Disable , Unit of measurement: - , Notes: Only valid for single pump system
116	S16	R&W	T_Cool_Diff	Differential temperature in cooling mode , Range: 1 ~ 5 , Default: 2 , Unit of measurement: [°C] , Notes:
117	S16	R&W	T_Heat_Diff	Differential temperature in heating mode , Range: 1 ~ 5 , Default: 2 , Unit of measurement: [°C] , Notes:
118	S16	R&W	dT5_ON	Return hot water temperature difference , Range: 2 ~ 10 , Default: 8 , Unit of measurement: [°C] , Notes:
119	U16	R&W	T_Heat1_Delay	Heat1 start time delay , Range: 60 ~ 240 , Default: 90 , Unit of measurement: [min] , Notes: Valid only for HP models
120	S16	R&W	dTw_Heat1_Off	Range: 2 ~ 10 , Default: 5 , Unit of measurement: [°C] , Notes: Valid only for HP models
121	S16	R&W	Tw differential temperature (TW_COOL DIFF/TW_HEAT_DIFF)	Range: 1 ~ 5 , Default: 2 , Unit of measurement: [°C] , Notes:
122	S16	R&W	Ratio_Cool_First	Initial turn on ratio of cascade system in cooling mode , Range: 5 ~ 100 , Default: 50 , Unit of measurement: [%] , Notes: 5% step
123	S16	R&W	Ratio_Heat_First	Initial turn on ratio of cascade system in heating mode , Range: 5 ~ 100 , Default: 50 , Unit of measurement: [%] , Notes: 5% step
124	S16	R&W	T_diff_pro	Inlet and outlet water temperature difference protection , Range: 5 ~ 100 , Default: 50 , Unit of measurement: [%] , Notes: 5% step
125	S16	R&W	T_Frost	Defrost cycle time , Range: 20 ~ 180 , Default: 45 , Unit of measurement: [min] , Notes:
126	S16	R&W	T_Defrost_in	Defrost entry temperature , Range: -5 ~ 5 , Default: -2 , Unit of measurement: [°C] , Notes:
127	S16	R&W	T_Defrost_out	Defrost exit temperature , Range: -10 ~ 10 , Default: 0 , Unit of measurement: [°C] , Notes:
128	S16	R&W	Heat 1 enable	Range: 0 - Disable, 1 - Enable , Default: 0 - Disable , Unit of measurement: - , Notes:
129	S16	R&W	T4_Heat1_On	Range: -5 ~ 20 , Default: 5 , Unit of measurement: [°C] , Notes:
130	S16	R&W	Tw_Heat1_On	Range: -5 ~ 20 , Default: 5 , Unit of measurement: [°C] , Notes: Valid only for FC/CO models
131	S16	R&W	Tw_Heat1_Off	Range: -5 ~ 20 , Default: 5 , Unit of measurement: [°C] , Notes: Valid only for FC/CO models
132	S16	R&W	Heat 2 enable	Range: 0 - Disable, 1 - Enable , Default: 0 - Disable , Unit of measurement: - , Notes: Only valid for single pump system with DHW function
133	S16	R&W	T_Heat2_delay	Heat 2 turn on delay , Range: 60 ~ 240 , Default: 90 , Unit of measurement: [min] , Notes: 5 min step. Only valid for single pump system with DHW function
134	S16	R&W	dT5_Heat2_Off	Range: 2 ~ 10 , Default: 5 , Unit of measurement: [min] , Notes: Only valid for single pump system with DHW function
135	S16	R&W	T4_Heat2_On	Range: -5 ~ 20 , Default: 5 , Unit of measurement: [°C] , Notes: Only valid for single pump system with DHW function

Reg	Data Type	R/W	Name	Description
136	S16	R&W	Inverter pump enable	Range: 0 - Disable, 1 - Enable , Default: 0 - Disable , Unit of measurement: - , Notes: Valid only for single pump system
137	S16	R&W	Inverter pump running speed	Range: 30 ~ 100 , Default: 100 , Unit of measurement: [%] , Notes: 5% step. Only valid if register 136 is enabled
138	S16	R&W	Modbus control enable	Range: 0 - Disable, 1 - Enable , Default: 0 - Disable , Unit of measurement: - , Notes: Enable this item bofer writing other Modbus registers
139	S16	R&W	Gycol type	Range: 0 - Ethylene, 1 - Propylene , Default: 0 - Ethylene , Unit of measurement: - , Notes:
140	S16	R&W	Glycol percentage	Range: 0 ~ 50 , Default: 0 , Unit of measurement: [%] , Notes: 5% step
141	S16	R&W	Paf offset	Protection pressure compensation , Range: 0 ~ 20 , Default: 0 , Unit of measurement: 0.01Mpa , Notes: step of 5
142	S16	R&W	Water coil control	Range: 0 - Automatic, 1 - Manual1 (through), 2 - Manual2 (bypass) , Default: 0 - Automatic , Unit of measurement: - , Notes: Valid only on FC units
143	S16	R&W	DtTws	Tws rising value after entering mix , Range: 1 ~ 3 , Default: 1 , Unit of measurement: [°C] , Notes: Only valid for FC/CO unit
144	S16	R&W	Dtmix	Enter mix hysteresis , Range: 1 ~ 3 , Default: 2 , Unit of measurement: [%] , Notes: Only valid for FC/CO unit
145	S16	R&W	FC Offset	FC enter offset , Range: 1 ~ 15 , Default: 3 , Unit of measurement: [°C] , Notes: Only valid for FC/CO unit
146	S16	R&W	FC Hyster	FC enter hysteresis , Range: 1 ~ 3 , Default: 1 , Unit of measurement: [°C] , Notes: Only valid for FC/CO unit
147	S16	R&W	TWI_O ABNORMAL	Abnormal differ between inlet and outlet water temperature , Range: 1 ~ 5 , Default: 2 , Unit of measurement: [°C] , Notes:
148	S16	R&W	Low outlet water control	Range: 0 ~ 20 , Default: 7 , Unit of measurement: [°C] , Notes:
149	S16	R&W	Power limit	Energy saving level , Range: 40 ~ 100 , Default: 40 , Unit of measurement: [%] , Notes: 10% step
150	S16	R&W	E9 protection time	Water flow switch protection time , Range: 2 ~ 20 , Default: 5 , Unit of measurement: [s] , Notes:
151	S16	R&W	E9 detection method	Range: 0 - Water flow detected before the pump is turned on , 1 - Water flow switch is detected after the pump is turned on , Default: 0 , Unit of measurement: - , Notes:
152	S16	R&W	Inverter pump MIN speed	Range: 40 ~ Max(100, Inverter pump MAX speed) , Default: 75 , Unit of measurement: [%] , Notes: 5% step. Only valid for multiple pump system
153	S16	R&W	Inverter pump MAX speed	Range: MIN(70, Inverter pump MIN speed) ~ 100 , Default: 75 , Unit of measurement: [%] , Notes: 5% step. Only valid for multiple pump system
154	S16	R&W	Pump turn on time	Range: 5 ~ 60 , Default: 5 , Unit of measurement: [min] , Notes: 5 min step
155	S16	R&W	Pump turn off time	Range: 0 ~ 60 , Default: 0 , Unit of measurement: [%] , Notes: 5 min step
156	S16	R&W	TW_COOL_DIFF	Differential temperature Tw in cooling mode , Range: 1 ~ 5 , Default: 2 , Unit of measurement: [°C] , Notes:
157	S16	R&W	TW_HEAT_DIFF	Differential temperature Tw in heating mode , Range: 1 ~ 5 , Default: 2 , Unit of measurement: [°C] , Notes:

Reg	Data Type	R/W	Name	Description
158	U16	R&W	Heat1 force on	Range: 0 - ON, 1 - OFF , Default: 0 - OFF , Unit of measurement: - , Notes:
159 ~ 199			RESERVED	
200+(Unit Address)*100	S16	R&W	RESERVED	
201+(Unit Address)*100	S16	R&W	Heat 2 enable	Range: 0 - Disable, 1 - Enable , Default: 0 - Disable , Unit of measurement: - , Notes: Only valid for multi pump systems with DHW function
202+(Unit Address)*100	S16	R&W	Heat 2 force on	Range: 0 - ON, 1 - OFF , Default: 0 - OFF , Unit of measurement: - , Notes: Only valid for multi pump systems with DHW function
203+(Unit Address)*100	S16	R&W	T-HEAT2-DELAY	Heat 2 opening delay , Range: 60 ~ 240 , Default: 90 , Unit of measurement: [min] , Notes: Only valid for multi pump systems with DHW function
204+(Unit Address)*100	S16	R&W	DT-HEAT2-OFF	Heat2 turn off delta temperature , Range: 2 ~ 10 , Default: 5 , Unit of measurement: [°C] , Notes: Only valid for multi pump systems with DHW function
205+(Unit Address)*100	S16	R&W	T4-HEAT2-ON	Range: -5 ~ 20 , Default: 5 , Unit of measurement: [°C] , Notes: Only valid for multi pump systems with DHW function
206+(Unit Address)*100	S16	R&W	DHW enable	Range: 0 - Disable, 1 - Enable , Default: 0 - Disable , Unit of measurement: - , Notes: Only valid for multi pump systems
207+(Unit Address)*100	S16	R&W	DHW turn on	Range: 0 - OFF, 1 - ON , Default: 0 - OFF , Unit of measurement: - , Notes: Only valid for multi pump systems
208+(Unit Address)*100	S16	R&W	DHW priority	Range: 0 - OFF, 1 - ON , Default: 0 - OFF , Unit of measurement: - , Notes: Only valid for multi pump systems
209+(Unit Address)*100	S16	R&W	DHW cooling MAX running time	Range: 1 ~ 48 , Default: 16 , Unit of measurement: [min] , Notes: Only valid for multi pump systems with DHW function
210+(Unit Address)*100	S16	R&W	DHW cooling MIN running time	Range: 1 ~ 48 , Default: 1 , Unit of measurement: [min] , Notes: Only valid for multi pump systems with DHW function
211+(Unit Address)*100	S16	R&W	DHW heating MAX running time	Range: 1 ~ 48 , Default: 16 , Unit of measurement: [min] , Notes: Only valid for multi pump systems with DHW function
212+(Unit Address)*100	S16	R&W	DHW heating MIN running time	Range: 1 ~ 48 , Default: 1 , Unit of measurement: [min] , Notes: Only valid for multi pump systems with DHW function
213+(Unit Address)*100	S16	R&W	DHW MAX running time in DHW mode	Range: 1 ~ 48 , Default: 16 , Unit of measurement: [min] , Notes: Only valid for multi pump systems with DHW function
214+(Unit Address)*100	S16	R&W	DHW MIN running time in DHW mode	Range: 1 ~ 48 , Default: 1 , Unit of measurement: [min] , Notes: Only valid for multi pump systems with DHW function
215+(Unit Address)*100	S16	R&W	Inverter pump enable	Range: 0 - Disable, 1 - Enable , Default: 0 - Disable , Unit of measurement: - , Notes: Only valid for multi pump systems
216+(Unit Address)*100	S16	R&W	Inverter pump running speed	Range: 30 ~ 100 , Default: 100 , Unit of measurement: [%] , Notes: 5% step. Only valid for multi pump systems
217+(Unit Address)*100	S16	R&W	T5S	Water tank setpoint , Range: 30 ~ 60 , Default: 50 , Unit of measurement: [°C] , Notes: Only valid for multi pump systems with DHW function
218+(Unit Address)*100	U16	R&W	DHW disinfection enable	Range: 0 - Disable, 1 - Enable , Default: 0 - Disable , Unit of measurement: - , Notes: Only valid for systems with DHW function

Reg	Data Type	R/W	Name	Description
219+(Unit Address)*100	U16	R&W	Day of the week	Day of the week in which the DHW disinfection is performed , Range: 0 - Monday, 1 - Tuesday, 2 - Wednesday, 3 - Thursday, 4 - Friday, 5 - Saturday, 6 - Sunday , Default: 5 - Saturday , Unit of measurement: - , Notes: Only valid for systems with DHW function
220+(Unit Address)*100	U16	R&W	Time	DHW disinfection function starting time , Range: 0 ~ 1440 , Default: 0 , Unit of measurement: min , Notes: Only valid for systems with DHW function. The daytime is calculated as follows: DayHour = Time/60, DayMinute = Time%60.
221+(Unit Address)*100	U16	R&W	Max running time	DHW disinfection function maximum running time , Range: 60 ~ 180 , Default: 60 , Unit of measurement: min , Notes: Only valid for systems with DHW function
(222 ~ 229)+(Unit Address)*100			RESERVED	
230+(Unit Address)*100		RO	RESERVED	
231+(Unit Address)*100		RO	RESERVED	
232+(Unit Address)*100	U16	RO	Current capacity	Real time capacity , Range: 0 ~ 65535 , Default: - , Unit of measurement: [kW] , Notes:
233+(Unit Address)*100	U16	RO	Current power	Real time power consumption , Range: 0 ~ 65535 , Default: - , Unit of measurement: [kW] , Notes:
234+(Unit Address)*100	U16	RO	Current efficiency	Current capacity / Current power *100 , Range: 0 ~ 100 , Default: - , Unit of measurement: [%] , Unit:
235+(Unit Address)*100	U16	RO	Total capacity	Range: 0 ~ 65535 , Default: - , Unit of measurement: [MWh] , Notes:
236+(Unit Address)*100	U16	RO	Total power	Total power consumption , Range: 0 ~ 65535 , Default: - , Unit of measurement: [kWh] , Notes:
237+(Unit Address)*100	U16	RO	SG status	Range: 0 - OFF, 1 - ON , Default: - , Unit of measurement: - , Notes:
238+(Unit Address)*100	U16	RO	EVU status	Range: 0 - OFF, 1 - ON , Default: - , Unit of measurement: - , Notes:
239+(Unit Address)*100	S16	RO	Ts final	Range: -32768 ~ 32767 , Default: - , Unit of measurement: [°C] , Notes: Invalid value 0x8000
240+(Unit Address)*100	S16	RO	ODU running mode	Range: 1 - Off, 2 - Cooling, 3 - Heating, 4 - DHW , Default: - , Unit of measurement: - , Notes:
241+(Unit Address)*100	S16	RO	Silent mode	Range: 1 - Standard, 2 - Silent, 3 - Night silent, 7 - Super silent , Default: - , Unit of measurement: - , Notes:
242+(Unit Address)*100	S16	RO	T5S	Water tank setpoint , Range: -32768 ~ 32767 , Default: - , Unit of measurement: [°C] , Notes: Invalid value 0x8000
243+(Unit Address)*100	S16	RO	RESERVED	
244+(Unit Address)*100	S16	RO	Tw1	Inlet water temperature , Range: -32768 ~ 32767 , Default: - , Unit of measurement: [°C] , Notes: Invalid value 0x8000
245+(Unit Address)*100	S16	RO	Two	Outlet water temperature , Range: -32768 ~ 32767 , Default: - , Unit of measurement: [°C] , Notes: Invalid value 0x8000
246+(Unit Address)*100	S16	RO	Tw	Water temperature , Range: -32768 ~ 32767 , Default: - , Unit of measurement: [°C] , Notes: Invalid value 0x8000
247+(Unit Address)*100	S16	RO	T4	Ambient temperature , Range: -32768 ~ 32767 , Default: - , Unit of measurement: [°C] , Notes: Invalid value 0x8000

Reg	Data Type	R/W	Name	Description
248+(Unit Address)*100	S16	RO	Compressor frequency	Range: -32768 ~ 32767 , Default: - , Unit of measurement: [Hz] , Notes:
249+(Unit Address)*100	S16	RO	Compressor 1 current	Range: -32768 ~ 32767 , Default: - , Unit of measurement: [A] , Notes: Invalid value 0x8000
250+(Unit Address)*100	S16	RO	Fan 1 speed	Range: 0 ~ 100 , Default: - , Unit of measurement: [%] , Notes:
251+(Unit Address)*100	S16	RO	Fan 2 speed	Range: 0 ~ 100 , Default: - , Unit of measurement: [%] , Notes:
252+(Unit Address)*100	S16	RO	Fan 3 speed	Range: 0 ~ 100 , Default: - , Unit of measurement: [%] , Notes:
253+(Unit Address)*100	U16	RO	EXVA	EXV A current opening degree , Range: 0 ~ 65535 , Default: - , Unit of measurement: [steps] , Notes:
254+(Unit Address)*100	U16	RO	EXVB	EXV B current opening degree , Range: 0 ~ 65535 , Default: - , Unit of measurement: [steps] , Notes:
255+(Unit Address)*100	U16	RO	EXVC	EXV C current opening degree , Range: 0 ~ 65535 , Default: - , Unit of measurement: [steps] , Notes:
256+(Unit Address)*100	S16	RO	SV4	Range: 0 - OFF, 1 - ON , Default: - , Unit of measurement: - , Notes:
257+(Unit Address)*100	S16	RO	SV5	Range: 0 - OFF, 1 - ON , Default: - , Unit of measurement: - , Notes:
258+(Unit Address)*100	S16	RO	SV8A	Range: 0 - OFF, 1 - ON , Default: - , Unit of measurement: - , Notes:
259+(Unit Address)*100	S16	RO	SV8B	Range: 0 - OFF, 1 - ON , Default: - , Unit of measurement: - , Notes:
260+(Unit Address)*100	S16	RO	4 way valve	Range: 0 - OFF, 1 - ON , Default: - , Unit of measurement: - , Notes:
261+(Unit Address)*100	S16	RO	Fix pump state	Range: 0 - OFF, 1 - ON , Default: - , Unit of measurement: - , Notes:
262+(Unit Address)*100	S16	RO	SV1 state	Range: 0 - OFF, 1 - ON , Default: - , Unit of measurement: - , Notes:
263+(Unit Address)*100	S16	RO	SV2 state	Range: 0 - OFF, 1 - ON , Default: - , Unit of measurement: - , Notes:
264+(Unit Address)*100	S16	RO	Heat 1 state	Range: 0 - OFF, 1 - ON , Default: - , Unit of measurement: - , Notes:
265+(Unit Address)*100	S16	RO	Heat 2 state	Range: 0 - OFF, 1 - ON , Default: - , Unit of measurement: - , Notes:
266+(Unit Address)*100	S16	RO	Tp1	Range: -32768 ~ 32767 , Default: - , Unit of measurement: [°C] , Notes: Invalid value 0x8000
267+(Unit Address)*100	S16	RO	Th	Range: -32768 ~ 32767 , Default: - , Unit of measurement: [°C] , Notes: Invalid value 0x8000
268+(Unit Address)*100	S16	RO	T3	Range: -32768 ~ 32767 , Default: - , Unit of measurement: [°C] , Notes: Invalid value 0x8000
269+(Unit Address)*100	S16	RO	Tz	Range: -32768 ~ 32767 , Default: - , Unit of measurement: [°C] , Notes: Invalid value 0x8000
270+(Unit Address)*100	S16	RO	T5	Range: -32768 ~ 32767 , Default: - , Unit of measurement: [°C] , Notes: Invalid value 0x8000
271+(Unit Address)*100	S16	RO	Pressure	Range: -32768 ~ 32767 , Default: - , Unit of measurement: [°C] , Notes: Low pressure in cooling mode, high pressure in heating mode. Invalid value 0x8000

Reg	Data Type	R/W	Name	Description
272+(Unit Address)*100	U16	RO	Error Code	Range: 0-65535 [0-No Error] , Default: - , Unit of measurement: - , Notes: refer to sheet error code define.
273+(Unit Address)*100	U16	RO	Last error code of the error history	Range: 0-65535 [0-No Error] , Default: - , Unit of measurement: - , Notes: refer to sheet error code define.
274+(Unit Address)*100	U16	RO	HMI software version	Version number , Range: 0 ~ 65535 , Default: - , Unit of measurement: - , Notes:
275+(Unit Address)*100	S16	RO	Tp2	Range: -32768 ~ 32767 , Default: - , Unit of measurement: [°C] , Notes: Invalid value 0x8000
276+(Unit Address)*100	S16	RO	T5s min	Range: -32768 ~ 32767 , Default: - , Unit of measurement: [°C] , Notes: Invalid value 0x8000
277+(Unit Address)*100	S16	RO	T6A	Range: -32768 ~ 32767 , Default: - , Unit of measurement: [°C] , Notes: Invalid value 0x8000
278+(Unit Address)*100	U16	RO	HMI error code	Range: 0-65535 [0-No Error] , Default: - , Unit of measurement: - , Notes: refer to sheet error code define.
279+(Unit Address)*100	S16	RO	SV6 state	Range: 0 - OFF, 1 - ON , Default: - , Unit of measurement: - , Notes:
280+(Unit Address)*100	S16	RO	Compressor 2 current	Range: -32768 ~ 32767 , Default: - , Unit of measurement: [A] , Notes: Invalid value 0x8000
281+(Unit Address)*100	U16	RO	Unit Capacity	Unit size , Range: 0 ~ 65535 , Default: - , Unit of measurement: [kW] , Notes:
282+(Unit Address)*100	S16	RO	Defrost status	Range: 0 - OFF, 1 - ON , Default: - , Unit of measurement: - , Notes:
283+(Unit Address)*100	S16	RO	Anti-freezing electric heater	Range: 0 - OFF, 1 - ON , Default: - , Unit of measurement: - , Notes:
284+(Unit Address)*100	S16	RO	Remote control	Range: 0 - OFF, 1 - ON , Default: - , Unit of measurement: - , Notes: Only the master unit provides this value
285+(Unit Address)*100	S16	RO	FCT status	Range: 0 - OFF, 1 - ON , Default: - , Unit of measurement: - , Notes: Only the master unit provides this value
286+(Unit Address)*100	S16	RO	Pump system status	Range: 0 - Single pump, 1 - Multi pump , Default: - , Unit of measurement: - , Notes:
287+(Unit Address)*100	S16	RO	Unit type	Range: 0 - HP, 1 - CO, 2 - FC , Default: - , Unit of measurement: - , Notes:
288+(Unit Address)*100	S16	RO	T5s max	Range: -32768 ~ 32767 , Default: - , Unit of measurement: [°C] , Notes: Invalid value 0x8000
289+(Unit Address)*100	S16	RO	Tsafe	Range: -32768 ~ 32767 , Default: - , Unit of measurement: [°C] , Notes: Invalid value 0x8000
290+(Unit Address)*100	S16	RO	PAF	Range: -32768 ~ 32767 , Default: - , Unit of measurement: [kPa] , Notes: Invalid value 0x8000
291+(Unit Address)*100	S16	RO	Taf1	Range: -32768 ~ 32767 , Default: - , Unit of measurement: [°C] , Notes: Invalid value 0x8000
292+(Unit Address)*100	U16	RO	Mainboard software version	Version number , Range: 0 ~ 65535 , Default: - , Unit of measurement: - , Notes:
293+(Unit Address)*100	U16	RO	Mainboard software version date	Version date , Range: 0 ~ 65535 , Default: - , Unit of measurement: - , Notes: bit[0-4]: Day 1~31 , bit[5-8]: Month 1~12 , bit[9-15]: Year 0~127 (2000~2127)
294+(Unit Address)*100		RO	RESERVED	

Reg	Data Type	R/W	Name	Description
295+(Unit Address)*100	S16	RO	T6B	Range: -32768 ~ 32767 , Default: - , Unit of measurement: [°C] , Notes: Invalid value 0x8000
296+(Unit Address)*100	S16	RO	Taf2	Range: -32768 ~ 32767 , Default: - , Unit of measurement: [°C] , Notes: Invalid value 0x8000
297+(Unit Address)*100	S16	RO	Tfin1	Range: -32768 ~ 32767 , Default: - , Unit of measurement: [°C] , Notes: Invalid value 0x8000
298+(Unit Address)*100	S16	RO	Tfin2	Range: -32768 ~ 32767 , Default: - , Unit of measurement: [°C] , Notes: Invalid value 0x8000
299+(Unit Address)*100	S16	RO	Tfin3	Range: -32768 ~ 32767 , Default: - , Unit of measurement: [°C] , Notes: Invalid value 0x8000
1800 ~ 2299			RESERVED	
2300+(Unit Address)*200	S16	RO	TDSH	Range: -32768 ~ 32767 , Default: - , Unit of measurement: [°C] , Notes: Invalid value 0x8000
2301+(Unit Address)*200	S16	RO	TSSH	Range: -32768 ~ 32767 , Default: - , Unit of measurement: [°C] , Notes: Invalid value 0x8000
2302+(Unit Address)*200	S16	RO	TCSH	Range: -32768 ~ 32767 , Default: - , Unit of measurement: [°C] , Notes: Invalid value 0x8000
2303+(Unit Address)*200	U16	RO	Inverter pump running speed	Range: 0-100 , Default: - , Unit of measurement: [%] , Notes: Invalid value 0x8000
2304+(Unit Address)*200	U16	RO	ErrTypeGet	Range: 0-65535 [0-No Error] , Default: - , Unit of measurement: - , Notes:
2305+(Unit Address)*200	U16	RO	ErrCodeGet	Range: 0-65535 [0-No Error] , Default: - , Unit of measurement: - , Notes:
2306+(Unit Address)*200	U16	RO	LastErrTypeGet	Range: 0-65535 [0-No Error] , Default: - , Unit of measurement: - , Notes:
2307+(Unit Address)*200	U16	RO	LastErrCodeGet	Range: 0-65535 [0-No Error] , Default: - , Unit of measurement: - , Notes:
(2308 ~ 2399)+(Unit Address)*200			RESERVED	

17. Technical information

Performance - EXC e PRM Version

Acoustic configuration with compressor soundproofing (SC)

Size			45.4	50.4	55.4	60.4	65.4	70.4	75.4	80.4	85.4	90.4
Cooling												
Cooling capacity	1	[kW]	104	113	129	143	158	173	186	201	215	232
Compressor power input	1	[kW]	30,3	34,8	42,7	38,3	45,4	53,0	52,7	58,6	64,7	74,1
Total power input	2	[kW]	33,9	38,5	46,3	43,8	50,8	58,5	58,1	64,1	70,1	79,6
Partial recovery heating capacity	3	[kW]	31,5	34,7	40,3	42,6	47,7	53,1	56,1	61,0	65,6	71,8
EER	1	-	3,07	2,95	2,78	3,27	3,11	2,96	3,21	3,14	3,06	2,91
Water flow-rate (User Side)	1	[l/s]	4,97	5,41	6,15	6,84	7,55	8,28	8,91	9,61	10,3	11,1
Internal exchanger pressure drop	1	[kPa]	16,6	19,4	24,5	16,3	19,6	23,2	26,6	30,6	34,5	39,7
Cooling capacity (EN14511:2022)	4	[kW]	104	113	129	143	158	173	186	201	214	232
Total power input (EN14511:2022)	4	[kW]	34,1	38,7	46,7	44,0	51,2	58,9	58,7	64,7	70,9	80,5
EER (EN14511:2022)	4	-	3,05	2,92	2,75	3,25	3,08	2,94	3,17	3,10	3,02	2,88
SEER	6	-	4,72	4,71	4,71	4,94	4,93	4,88	4,93	4,91	4,83	4,81
SEPR	7	-	6,01	5,99	5,90	6,18	6,15	6,10	6,17	6,14	6,04	6,01
Cooling capacity (AHRI 550/590)	5	[kW]	104	113	129	143	158	173	186	201	215	232
Total power input (AHRI 550/590)	5	[kW]	33,9	38,5	46,3	43,8	50,8	58,5	58,1	64,1	70,1	79,6
COPR	5	-	3,07	2,95	2,78	3,27	3,11	2,96	3,21	3,14	3,06	2,91
IPLV	5	-	4,59	4,58	4,61	4,86	4,85	4,78	4,83	4,84	4,74	4,71

Super-silenced acoustic configuration (EN)

Size			45.4	50.4	55.4	60.4	65.4	70.4	75.4	80.4	85.4	90.4
Cooling												
Cooling capacity	1	[kW]	92,6	101	114	124	141	154	170	179	191	206
Compressor power input	1	[kW]	27,6	31,8	38,9	31,5	38,4	48,2	49,9	54,5	60,1	67,4
Total power input	2	[kW]	30,6	34,7	41,9	35,9	42,8	52,6	54,4	59,0	64,5	71,8
Partial recovery heating capacity	3	[kW]	28,2	31,1	36,0	36,5	42,0	47,5	51,7	54,8	59,0	64,2
EER	1	-	3,03	2,90	2,74	3,45	3,29	2,93	3,13	3,04	2,96	2,87
Water flow-rate (User Side)	1	[l/s]	4,42	4,82	5,47	5,92	6,73	7,37	8,14	8,55	9,13	9,85
Internal exchanger pressure drop	1	[kPa]	13,4	15,7	19,8	12,5	15,9	18,8	22,5	24,7	27,8	32,0
Cooling capacity (EN14511:2022)	4	[kW]	92,5	101	114	124	141	154	170	179	191	206
Total power input (EN14511:2022)	4	[kW]	30,7	34,9	42,1	36,1	43,1	52,9	54,8	59,4	65,1	72,5
EER (EN14511:2022)	4	-	3,01	2,88	2,71	3,43	3,26	2,91	3,10	3,01	2,93	2,84
SEER	6	-	4,69	4,68	4,67	4,92	4,90	4,84	4,89	4,87	4,78	4,77
SEPR	7	-	5,96	5,94	5,82	6,15	6,13	6,05	6,12	6,09	5,97	5,96
Cooling capacity (AHRI 550/590)	5	[kW]	92,6	101	114	124	141	154	170	179	191	206
Total power input (AHRI 550/590)	5	[kW]	30,6	34,7	41,9	35,9	42,8	52,6	54,4	59,0	64,5	71,8
COPR	5	-	3,03	2,90	2,74	3,45	3,29	2,93	3,13	3,04	2,96	2,87
IPLV	5	-	4,44	4,43	4,44	4,70	4,69	4,60	4,65	4,66	4,55	4,54

II The Product complies with the European ErP Directive (Energy Related Products), which includes the Commission Regulation (EU) 2016/2281, also known as Ecodesign LOT21. Contains fluorinated greenhouse gases (GWP 675)

1. Data referring to the following conditions: Water temperature to the internal exchanger = 12/7 °C. Temperature of air entering the external exchanger = 35°C. Evaporator fouling factor = $0.44 \times 10^{(-4)}$ m² K/W
2. The Total Power Input value does not take into account the part related to the pumps and required to overcome the pressure drops for the circulation of the solution inside the exchangers.
3. Recovery exchanger water = 40/45°C
4. Data compliant to Standard EN 14511:2022 referred to the following conditions: internal exchanger water temperature = 12/7 °C. Entering external exchanger air temperature = 35°C
5. Data calculated in accordance with AHRI 550/590 under the following conditions: Water temperature to the internal exchanger = 6.7 °C. Water flow-rate 0.043 l/s per kW. Temperature of air entering the external exchanger = 35°C. Evaporator fouling factor = $0.18 \times 10^{(-4)}$ m² K/W
6. Data calculated in compliance with EN 14825:2018.
7. Data compliant according to EU regulation 2016/2281

Construction - EXC and PRM Version

Size		45.4	50.4	55.4	60.4	65.4	70.4	75.4	80.4	85.4	90.4
Compressor											
Type of compressors	1	ROTARY INVERTER					SCROLL INVERTER				
Refrigerant							R-32				
N° compressors	[Nr]	4	4	4	4	4	4	4	4	4	4
Rated power (C1)	[HP]	25	25	25	35	35	35	45	45	45	45
Rated power (C2)	[HP]	25	25	25	35	35	35	45	45	45	45
Std Capacity control steps							STEPLESS				
Oil charge (C1)	[l]	4,6	4,6	4,6	6,2	6,2	6,2	7,2	7,2	7,2	7,2
Oil charge (C2)	[l]	4,6	4,6	4,6	6,2	6,2	6,2	7,2	7,2	7,2	7,2
Refrigerant charge (C1)	[Kg]	6,5	6,5	6,5	9,5	9,5	9,5	10,0	10,0	10,0	10,0
Refrigerant charge (C2)	[Kg]	6,5	6,5	6,5	9,5	9,5	9,5	10,0	10,0	10,0	10,0
Refrigeration circuits	[Nr]	2	2	2	2	2	2	2	2	2	2
Internal exchanger											
Type of internal exchanger	2						PHE				
N. of internal exchanger	[Nr]	1	1	1	1	1	1	1	1	1	1
Water content (EXC)	[l]	75,8	75,8	75,8	110,0	110,0	110,0	110,0	110,0	110,0	110,0
Water content (PRM)	[l]	68,8	68,8	68,8	96,8	96,8	96,8	96,8	96,8	96,8	96,8
Minimum system water content	[l]	880	970	1090	1220	1350	1480	1590	1710	1830	1980
External exchanger											
Type of external exchanger	3						CCM				
Number of coils	[Nr]	2	2	2	2	2	2	2	2	2	2
External Section Fans											
Type of fans	4						AX				
Number of fans	[Nr]	2	2	2	3	3	3	3	3	3	3
Type of motor	5						BRUSHLESS DC				
Standard airflow (SC)	[l/s]	14500	14500	14500	21750	21750	21750	21750	21750	21750	21750
Standard airflow (EN)	[l/s]	12567	12567	12567	18850	18850	18850	18850	18850	18850	18850
Connections											
Water fittings		2"1/2	2"1/2	2"1/2	3"	3"	3"	3"	3"	3"	3"
Power supply											
Standard power supply							400/3/50				
Electrical data											
F.L.A. - Total	[A]	110	112	115	168	170	175	200	205	211	216
F.L.I. - Total	[kW]	69,9	71,0	73,2	75,3	76,4	78,7	99,5	102,0	105	107
M.I.C. - Value	[A]	59	59	59	89	89	89	111	111	111	111

1. PHE = Plate exchanger
2. CCM = Aluminum microchannel condensing coils
3. AX = Axial fan
4. M.I.C.=Maximum unit starting current. The M.I.C. value is obtained adding the max. compressor starting current of the highest size to the power input at max. admissible conditions (F.L.A.) of the remaining electric components.

Voltage unbalance between phases: max 2 %

Voltage variation: max +/- 10%

Electrical data refer to standard units; according to the installed accessories, the data can suffer some variations.

Sound level

Acoustic configuration with compressor soundproofing (SC)

SIZE	Sound Power Level								Sound Pressure Level dB(A)	Sound Power Level dB(A)
	Octave band (Hz)									
	63	125	250	500	1000	2000	4000	8000		
45.4	78	74	73	76	80	80	71	71	66	84
50.4	78	74	73	76	80	80	71	71	66	84
55.4	78	74	73	76	80	80	71	71	66	84
60.4	83	79	76	79	83	81	73	73	68	87
65.4	83	79	76	79	83	81	73	73	68	87
70.4	84	80	77	80	84	82	74	74	69	88
75.4	86	82	83	81	84	84	76	76	70	89
80.4	86	82	83	81	84	84	76	76	70	89
85.4	86	82	83	81	84	84	76	76	70	89
90.4	86	82	83	81	84	84	76	76	70	89

Super-silenced acoustic configuration (EN)

SIZE	Sound Power Level								Sound Pressure Level dB(A)	Sound Power Level dB(A)
	Octave band (Hz)									
	63	125	250	500	1000	2000	4000	8000		
45.4	74	69	68	70	76	71	67	66	60	78
50.4	74	69	68	70	76	71	67	66	60	78
55.4	74	69	68	70	76	71	67	66	60	78
60.4	65	65	69	73	79	74	68	70	62	81
65.4	65	65	69	73	79	74	68	70	62	81
70.4	66	66	70	74	80	75	69	71	63	82
75.4	80	83	76	77	80	76	72	73	65	84
80.4	80	83	76	77	80	76	72	73	65	84
85.4	80	83	76	77	80	76	72	73	65	84
90.4	80	83	76	77	80	76	72	73	65	84

Sound levels refer to full load units, in test nominal conditions. The sound pressure level refers to 1 m. from the standard unit outer surface operating in open field. Measures according to UNI EN ISO 9614-2 regulations, with respect to the EUROVENT 8/1 certification, which provides for a tolerance of 3 dB(A).

Data referred to the following conditions:

- cold side exchanger water temperature = 12/7 °C

Entering external exchanger air temperature = 35°C

Operating range - Cooling

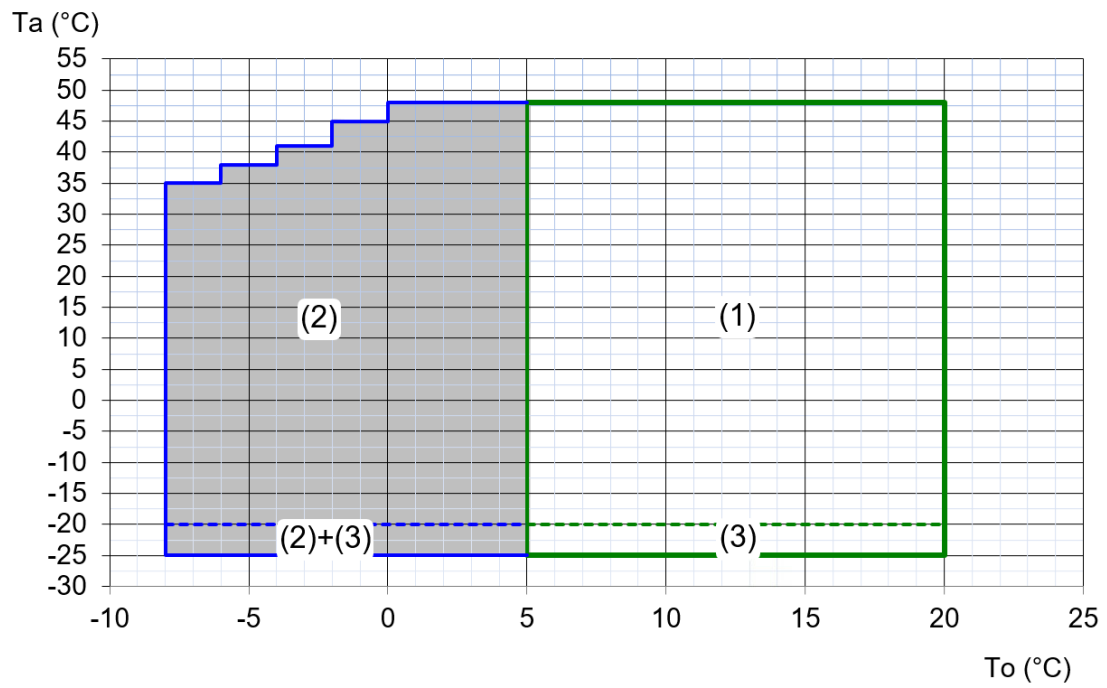

1. Standard unit operating range
2. Operating range where the use of glycol is mandatory in relation to the temperature of the outlet water from the user side exchanger
3. Unit operating range as given in the "Unit equipment with outdoor air low temperatures" table



FOR 30 YEARS WE HAVE BEEN OFFERING
SOLUTIONS FOR SUSTAINABLE
COMFORT AND THE WELL-BEING OF PEOPLE
AND THE ENVIRONMENT

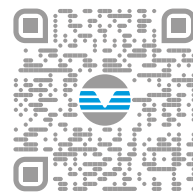

sales and assistance

Info & Contacts: www.clivet.com



MideaGroup
humanizing technology