



# EASYIn

## HQCN-NEE 1 IC

Manual  
for installation,  
and maintenance



en

M0TN00002-00 09-2024

Keep this manual with the wiring diagram in an accessible place for the operator.

---

Dear Customer,

We congratulate you on choosing these product.

Clivet has been working for years to offer systems able to assure the maximum comfort for a long time with highly-reliable, efficient, high-quality and safe solutions.

The target of the company is to offer advanced systems, that assure the best comfort and reduce energy consumption as well as the installation and maintenance costs for the entire life-cycle of the system.

With this manual, we want to give you information that are useful for all phases: from reception, installation and use to disposal - so that such an advanced system can provide the best performances during installation and use.

Best regards and have a good read.

CLIVET Spa

The original instructions are written in Italian.

All other languages are translations of the original instructions.

The data contained in this manual is not binding and may be changed by the manufacturer without prior notice. Reproduction, even partial, is FORBIDDEN.

© Copyright - CLIVET S.p.A. - Feltre (BL) - Italia.

# Summary

<b>1.</b>	<b>Glossary</b> .....	<b>5</b>
<b>2.</b>	<b>General</b> .....	<b>6</b>
2.1	About the manual.....	6
2.2	General safety warnings.....	7
<b>3.</b>	<b>Presentation of the product</b> .....	<b>8</b>
3.1	Identification.....	8
3.2	Regulatory framework.....	8
3.3	Intended use.....	8
3.4	Description.....	8
3.5	Main components.....	9
3.6	Components supplied with the unit.....	10
3.7	Component supply.....	10
3.8	Compatible accessories.....	10
<b>4.</b>	<b>Before installation</b> .....	<b>11</b>
4.1	Prerequisites.....	11
4.2	Reception.....	11
4.3	Storage.....	11
4.4	Handling.....	11
4.5	Removal of the packaging.....	12
<b>5.</b>	<b>Installation</b> .....	<b>14</b>
5.1	Prerequisites.....	14
5.2	General diagram.....	14
5.3	Access to internal parts.....	15
5.4	EASYBox module installation.....	17
5.5	Additional aesthetic practical cabinet for system accessories in full view	21
<b>6.</b>	<b>Water connections</b> .....	<b>25</b>
6.1	General system diagram.....	25
6.2	Position of connections.....	26
6.3	Hydraulic connection.....	26
6.4	Water filter.....	26
6.5	DHW safety valve.....	27
6.6	DHW tank filling.....	27
6.7	Loading the plant.....	28
<b>7.</b>	<b>Electrical connections</b> .....	<b>29</b>
7.1	Prerequisites.....	29
7.2	Cable inlet.....	30
7.3	Connecting the power supply.....	31
7.5	Keypad + bus connection.....	35
<b>8.</b>	<b>Starting up the system</b> .....	<b>36</b>
<b>9.</b>	<b>Maintenance</b> .....	<b>40</b>
9.1	Prerequisites.....	40
9.3	Unit booklet.....	42

---

9.4	Standby mode .....	42
9.5	Emptying the system.....	42
9.6	Structure .....	42
9.7	Water pressure.....	42
9.8	Water filter.....	42
9.9	Expansion vessel.....	42
9.10	Unit electrical panel.....	42
9.11	Using glycol .....	42
9.12	Magnetic sludge .....	43
9.13	Safety valve.....	43
9.14	Sacrificial anode.....	44
<b>10.</b>	<b>Decommissioning .....</b>	<b>45</b>
10.1	Disconnection .....	45
10.2	Residual risks .....	45
<b>11.</b>	<b>Technical data .....</b>	<b>46</b>

# 1. Glossary

Acronyms or abbreviations are used in this manual to indicate components or parameters. The acronyms and their meanings are given in the table.

Sign	Description
DHW	Domestic hot water
AHS	Backup boiler
HMI	User interface
IBH	Backup electric heater
OFN	Oxygen-Free-Nitrogen
P <sub>i</sub>	Outdoor packaged unit pump
P <sub>o</sub>	Secondary circuit pump (or Zone 1 pump for double zone systems)
P <sub>c</sub>	Zone 2 pump (for double zone systems)
P <sub>d</sub>	DHW recirculation pump
P <sub>s</sub>	Solar thermal circuit pump
P <sub>x</sub>	Defrosting status or alarm status
Pe	Evaporating pressure
Pc	Condensing pressure
SV1	3-way circuit/DHW diverter valve
SV2	3-way diverter valve for direct double zone systems
SV3	3-way mixing valve for mixed circuit
TBH	Backup electric heater for DHW tank
T1	Water supply temperature from additional heating source (with IBH heater or AHS boiler)
T2	Refrigerant temperature entering the user side exchanger (plate heat exchanger) in Cooling mode (or leaving in Heating mode)
T3	Refrigerant temperature leaving the source exchanger (coil) in Cooling mode (or entering in Heating mode)
T4	Outdoor air temperature
T5	DHW tank temperature
T1S	Water supply temperature setpoint
Ta	Room air temperature, detected by the probe in the HMI
Tbt1	Inertial storage tank temperature
Th	Compressor suction refrigerant temperature
Tp	Compressor discharge refrigerant temperature
Tsolar	Water temperature in the solar thermal circuit
Tw2	Water supply temperature for the mixed zone (for double zone systems)
TWin	Unit water return temperature
TWout	Unit water supply temperature

## 2. General

### 2.1 About the manual

- The manual ensures proper installation, use and maintenance of the unit
- this manual is an integral and essential part of the product
- keep this manual together with the wiring diagram in an accessible place for the operator. It should always accompany the product, even if it is transferred to another owner or user
- recipients of the instructions in the manual are indicated in the "Recipients" chapter
- the recipient is indicated at the beginning of each section of the manual
- recipients, to the extent of their responsibility, are required to read the instructions and warnings in this manual as they provide important information on safe installation, use and maintenance.

#### Remember that:

- the manufacturer The manufacturer accepts no liability for damage to persons or property resulting from failure to observe the rules in this manual
- failure to observe the instructions in this manual will result in forfeiture of the warranty
- the manufacturer reserves the right to make changes or improvements to this documentary material and to the units without prior notice
- visit the manufacturer's website for up-to-date details
- this manual contains proprietary information, all rights reserved, it may not be reproduced or photocopied, either in whole or in part, without the prior written consent of manufacturer.

#### 2.1.1 Symbols

The symbols in the following chapter can be found in the manual and on the product, and provide quick and clear information for correct and safe use.

##### 2.1.1.1 Safety symbols

#### Danger

This symbol indicates warnings, failure to comply may result in serious harm to health and fatal injuries.

#### Warning

This symbol indicates warnings, failure to comply may result in irreparable damage to the product or harm to the environment.

#### Prohibition

This symbol indicates operations that must never be

carried out.

#### Note

This symbol indicates important information.

##### 2.1.1.2 Editorial symbols

#### In the texts

**Purpose of the action:** indicates the purpose of a sequence of actions.

(it is identified by bold text followed by :)

- ▶ this symbol indicates actions that are required
- this symbol indicates the expected result after an action
- this symbol indicates the lists

#### In the images

1 uniquely indicates a component

 indicates a group of components

 indicates a sequence of actions

In the images, dimensions are expressed in millimetres unless otherwise indicated.

##### 2.1.1.3 Symbols on the unit

The following symbols are used in some parts of the product:



#### Instructions for the User

Read the User Manual carefully before using the product.



#### Instructions for the User

Read the Installer Manual carefully before installing the product.



#### Instructions for the Technical Support Service

Read the Technical Support Service Manual carefully before carrying out any operation on the product.

### 2.1.2 Recipients

#### 2.1.2.1 User

Inexperienced person who is capable of:

- operating the product safely for people, for the product and for the environment
- interpreting elementary diagnostics of faults and abnormal operating conditions
- carrying out simple adjustment, test and maintenance operations.

#### 2.1.2.2 Installer

Experienced and qualified person able to:

- to put the product in a safe operating condition for people, for the product and for the environment
- to comply with the regulations in force in the country of destination
- to provide the user with basic information on safe use and maintenance in accordance with this manual and current national regulations
- comply with the regulations in force in the country of destination.

#### 2.1.2.3 Technical support service

Experienced person, qualified and authorised directly by the manufacturer to:

- carry out a diagnosis of product faults and abnormal operation, possibly using information provided by the user
- rectify faults, carrying out the necessary repairs, replacements and adjustments that will restore the product's ability to function correctly and safely for the people, for the product and for the environment
- comply with the regulations in force in the country of destination.

### 2.1.3 Document organisation

- The manual is divided into sections, each dedicated to one or more recipients
- the recipient is indicated at the beginning of each section of the manual.

## 2.2 General safety warnings

 Read the "About the manual" chapter carefully before proceeding with any operation.

 Each chapter contains specific warnings for the operations given therein. These warnings should be read before starting any activities.

 For every operation, always comply with current national regulations.

 All personnel must be aware of the operations and of the hazardous situations that may arise when starting any operations on the unit.

 Any contractual and non-contractual liability for damage caused to persons, animals or property by installation, adjustment or maintenance errors or improper use is excluded.

 Any uses not expressly indicated in this manual are not permitted.

 Do not change or tamper with the device as this can lead to hazardous situations.

 Use appropriate safety clothing and equipment.

 The manufacturer accepts no liability for failure to comply with current safety and accident prevention regulations.

 The manufacturer reserves the right to make changes to its models at any time to improve its product, subject to the essential characteristics described in this manual.

 The manufacturer is not obliged to add these changes to units previously manufactured, already delivered or being built.

 The unit is suitable for use by children aged 8 years and over and by persons with reduced physical, sensory or mental capabilities or lack of experience or knowledge if they are properly supervised or have received instructions on the safe use of the device and have understood the associated hazardous situations. Children must not play with the device. Cleaning and maintenance operations must not be carried out by children without supervision.

 It is forbidden to touch the device with wet or damp parts of the body.

 It is forbidden to carry out any operation before disconnecting the device from the mains power supply by turning the system's main switch to "off".

 It is forbidden to change the safety or control devices without the device manufacturer's authorisation and instructions.

 It is forbidden to pull, unplug or twist the electrical cables coming out of the device, even if it is disconnected from the mains power supply.

 It is forbidden to introduce objects and substances through the air intake and supply grilles.

 It is forbidden to open the access doors to internal parts of the unit without first turning the system's main switch to "off".

## 3. Presentation of the product

### 3.1 Identification

The serial number label is positioned on the unit and allows to identify all the unit features.

The matriculation plate shows the indications foreseen by the standards, in particular:

- unit type
- serial number
- year of manufacture
- wiring diagram number
- electrical data
- manufacturer logo and address

**i** The serial number uniquely identifies each unit and enables specific parts to be identified.

**!** Tampering, removal, missing identification labels or anything else that does not allow the product to be safely identified, makes installation and maintenance operations difficult.

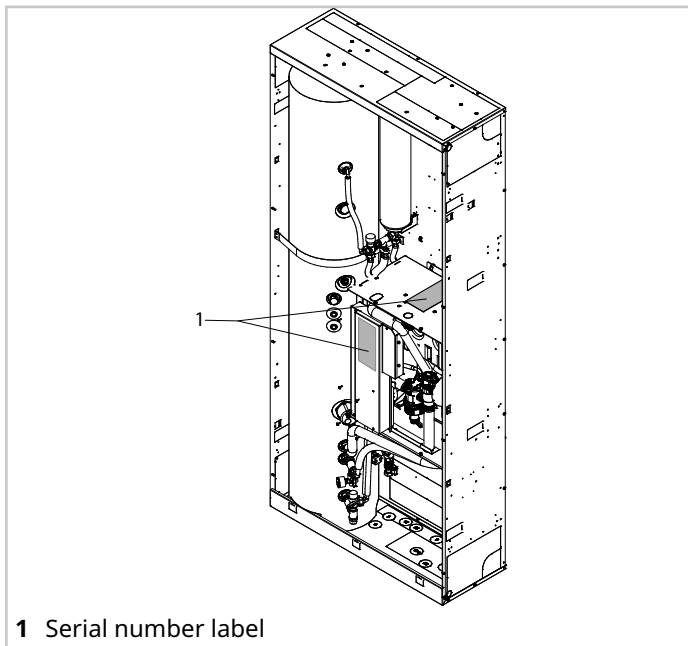

1 Serial number label

### 3.2 Regulatory framework

The relevant regulatory framework can be found in the declaration of conformity enclosed with this document.

### 3.3 Intended use

The units are designed for:

- combination with Edge EVO 2.0 - EXC and Edge F units
- indoor installation
- operation within the limits and with their performance characteristics set out in this document.

### 3.4 Description

Hydraulic module for combination with packaged heat pumps.



### 3.5 Main components

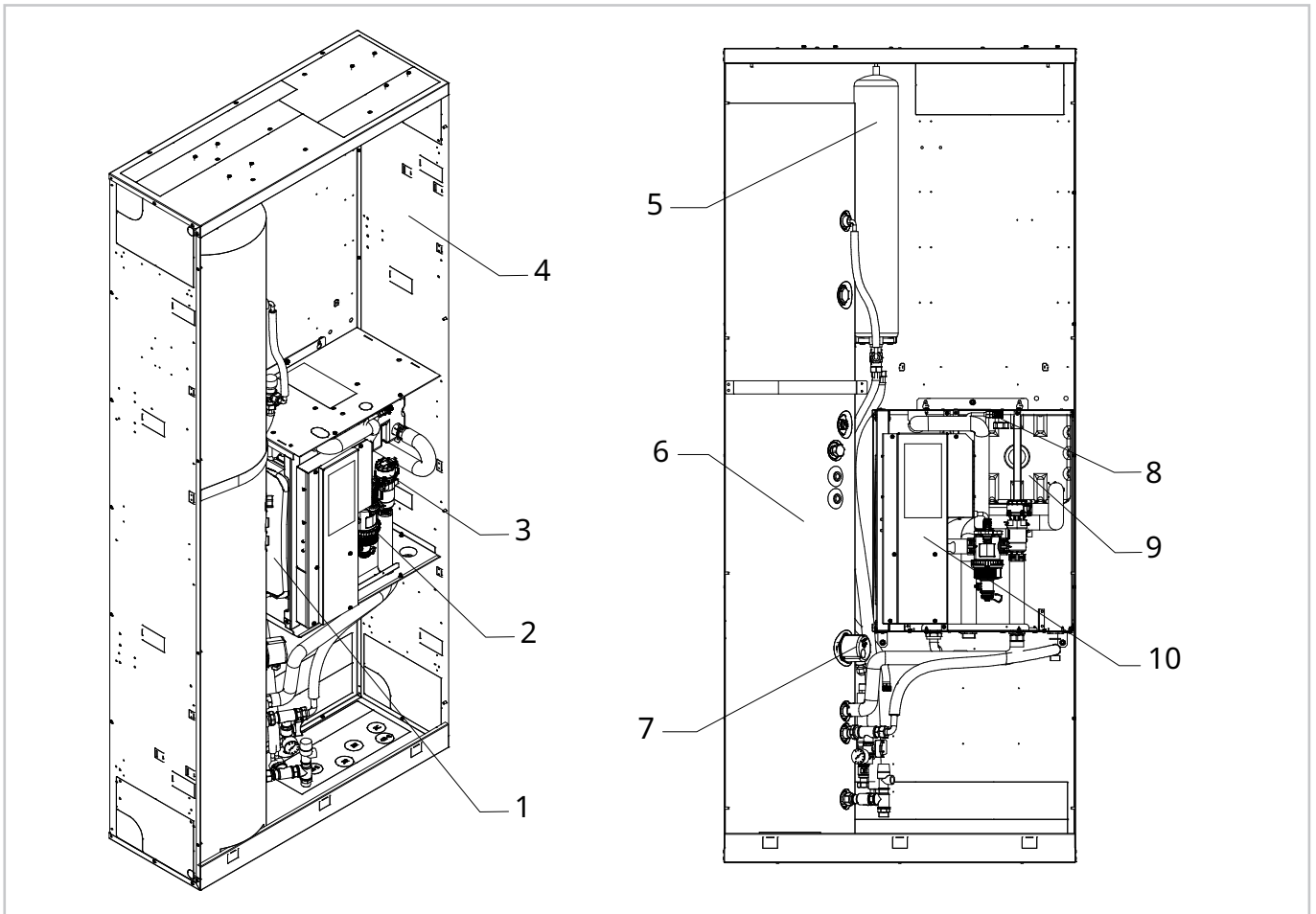

No.	Component
1	Expansion tank
2	Sludge
3	3-way valve
4	Uncased additional practical cabinet for system accessories
5	DHW expansion tank
6	DHW tank
7	Heating element 2kW
8	Air relief valve
9	Inertial 15-litre storage tank
10	Electrical panel

 The images are provided for illustrative purposes only.

### 3.6 Components supplied with the unit

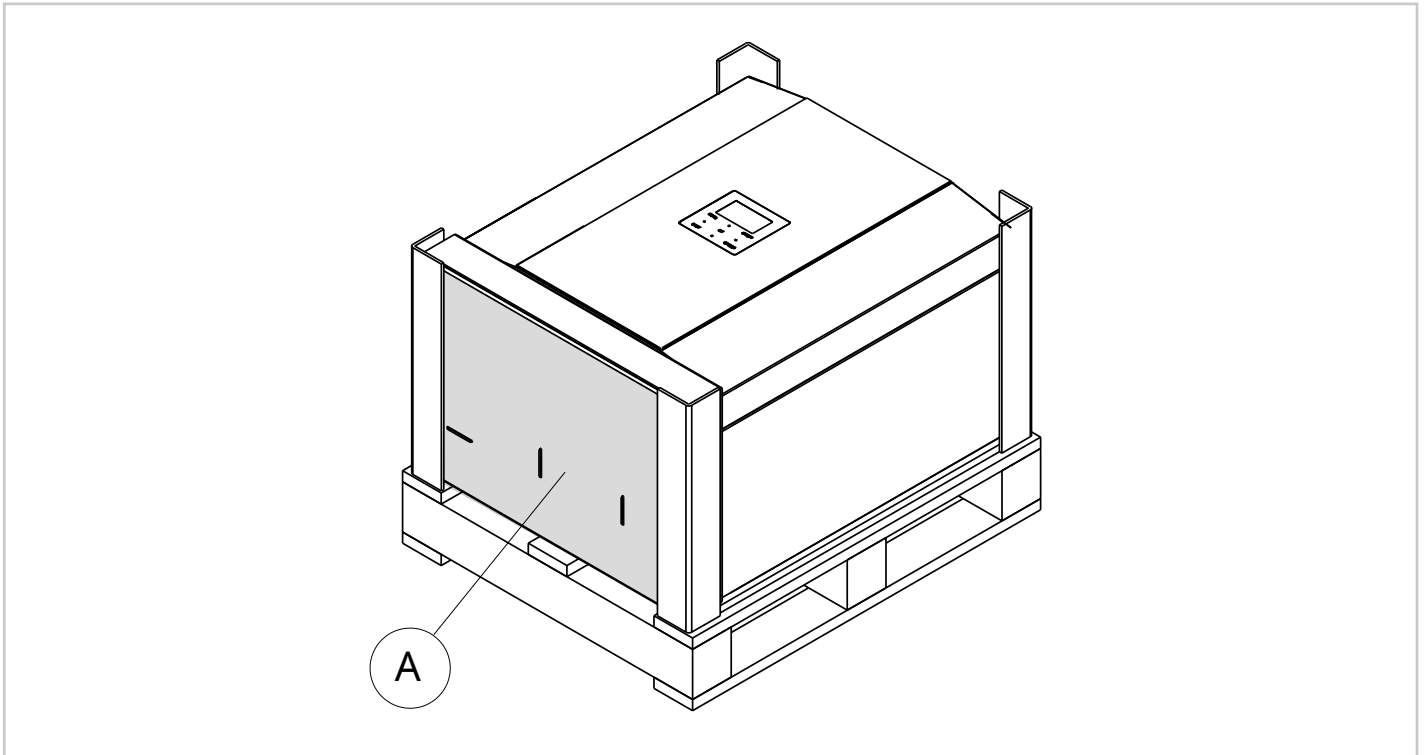

**A** Position of components supplied with the unit

The following components can be found in the package:

Description	Quantity
Installation and maintenance manual	1
TORX 1/4" insert	1
Quick-release fixing clip	1
Expansion tank gasket	1
O-ring	1

### 3.7 Component supply

**(i)** Check that all components for the installation of a standard unit have been supplied.

**The unit consists of 4 packs:**









- 1 Uncased additional practical cabinet for system accessories
- 2 Hydraulic module
- 3 DHW tank
- 4 Connection kit + hydraulic components

### 3.8 Compatible accessories

The list of accessories can be found in the technical bulletin.

## 4. Before installation

### 4.1 Prerequisites

-  This section is intended exclusively for the Installer.
-  Refer to the Technical data chapter for details.
-  When handling the unit, use equipment appropriate to the weight of the unit.
-  Check that all handling equipment complies with local safety regulations (cran, forklifts, ropes, hooks, etc.).
-  During manual operations, it is mandatory to comply with the maximum weight per person as required by current legislation.
-  Provide personnel with personal protective equipment appropriate for the situation, such as hard hat, gloves, safety shoes, etc.
-  Observe all safety procedures in order to guarantee the safety of the personnel present and the of material.
-  Keep the unit packed during handling.
-  Remove the packaging when you have reached the point of installation.

### 4.2 Reception

#### Before accepting the delivery, check:

- that the unit has not been damaged during transport
- that the materials delivered match those indicated on the transport document, comparing the data with the serial number label on the packaging.

#### In case of damage or anomaly:

- immediately write down the damage found on the transport document and quote this sentence: "Accepted with reservation due to evident shortages/damages during transport"
- refer to the contractual document.

-  Any disputes must be made within 8 days from the date of the delivery. Complaints after this period are invalid .

### 4.3 Storage

Respect the indications on the outside of the pack.

#### In particular:

- minimum ambient temperature  $-10\text{ }^{\circ}\text{C}$
- maximum ambient temperature  $+50\text{ }^{\circ}\text{C}$
- maximum relative humidity 95%

-  Exceeding these limits can cause irreversible damage to the unit.

### 4.4 Handling

#### The unit can be handled:

- with a forklift truck or pallet truck.

The following examples are guidelines; the choice of means and handling modes will depend on the actual installation situation.

#### 4.4.3.1 Lifting with a forklift truck

##### Hydraulic module

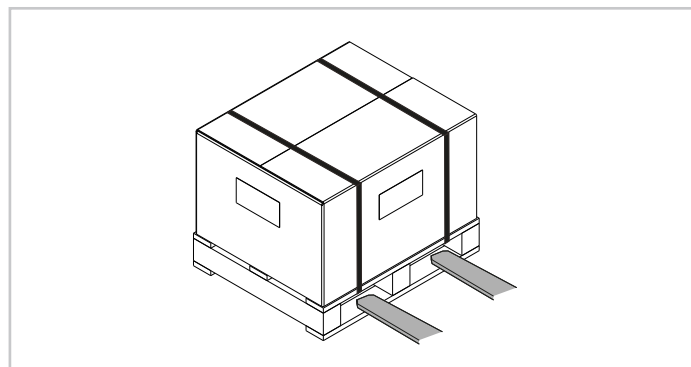

##### Uncased additional practical cabinet for system accessories

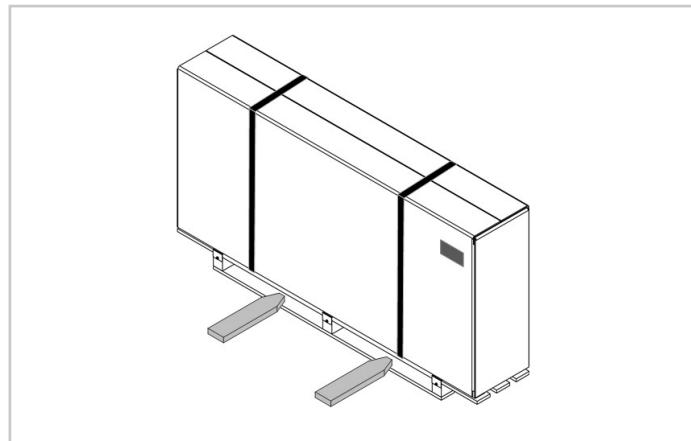

**150 litre water tank**

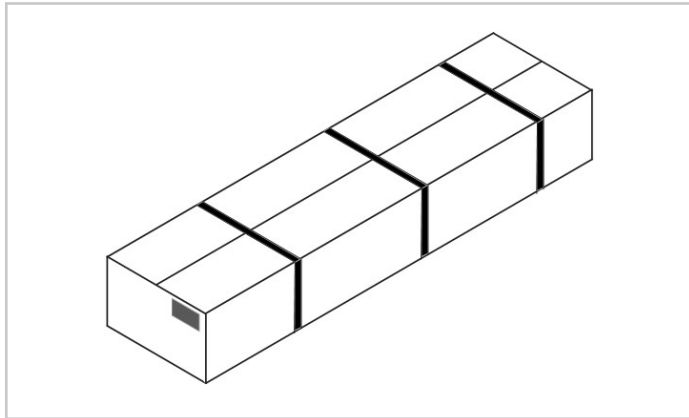

**Hydraulic connections kit**

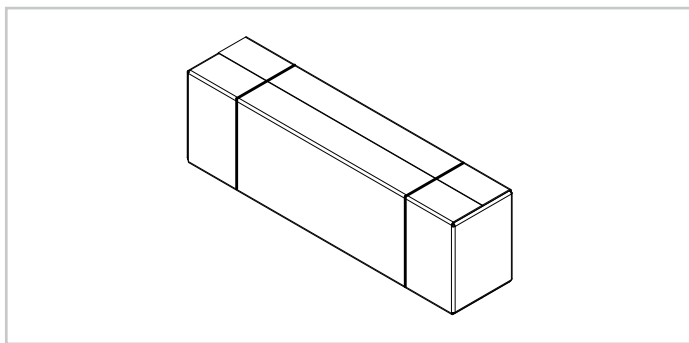

- When the load is lifted off the ground, stay clear of the area below and around it.
- Identify critical points during handling (disconnected routes, flights, steps, doors).
- Before starting the handling, make sure that the unit is stable.

**4.5 Removal of the packaging**

On reaching the installation site.

Carry out the following procedure:

- ▶ cut the straps

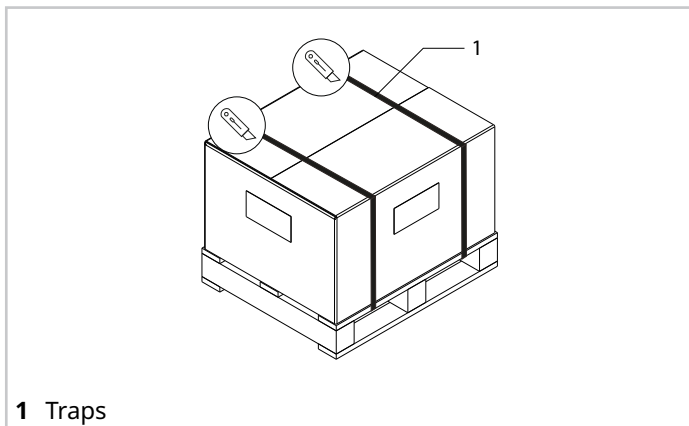

1 Traps

- ▶ lift and remove the packaging

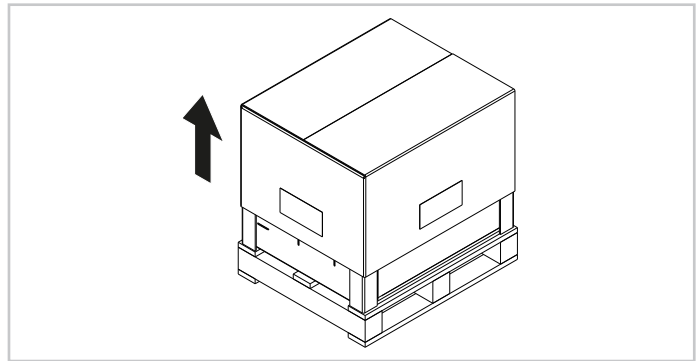

- ▶ remove the protection elements
- ▶ remove the components supplied

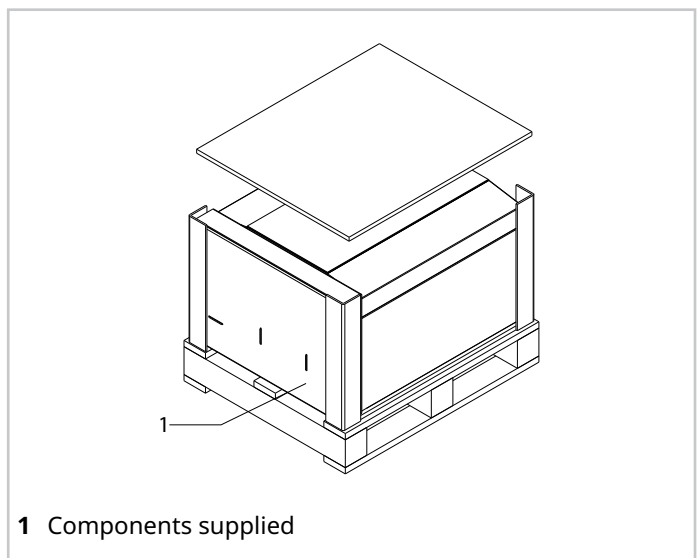

1 Components supplied

- ▶ remove the fixing screws from the pallet
- ▶ remove the unit with suitable means

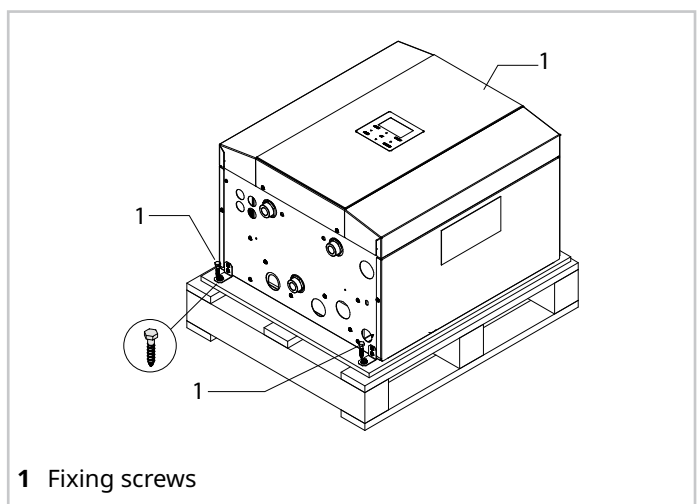

1 Fixing screws

- ▶ cut the straps

## Before installation

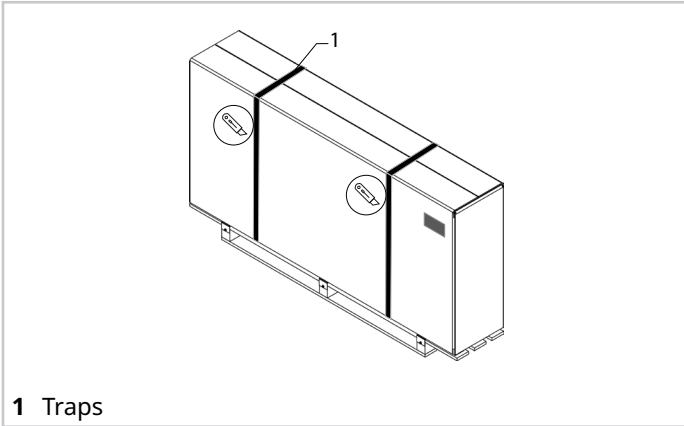

- ⚠ Be careful not to damage the unit.
- ⚠ Keep the packaging material out of children's reach as it may be dangerous.
- ♻ Recycle and dispose of the packaging material in conformity with local regulations.

► lift and remove the packaging

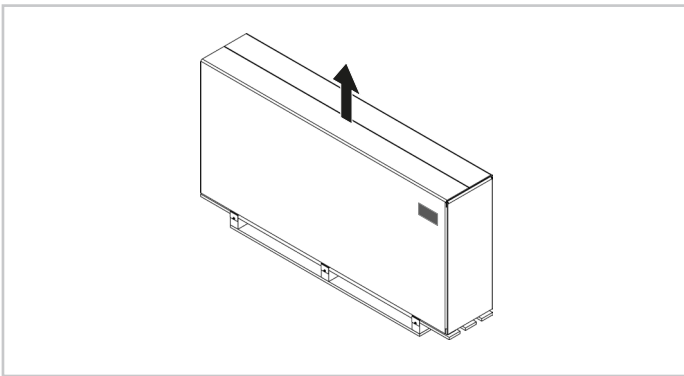

- cut the straps
- remove the packaging

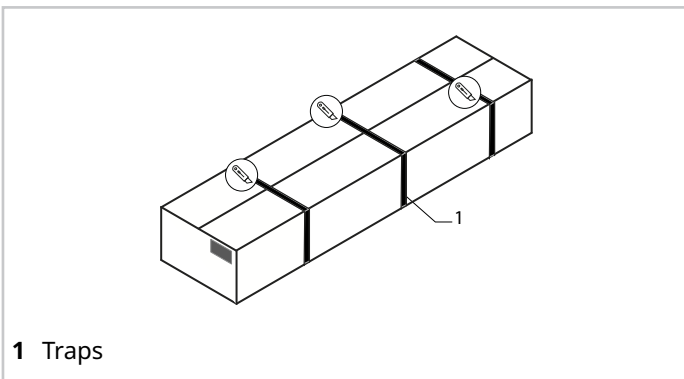

## Hydraulic connections kit

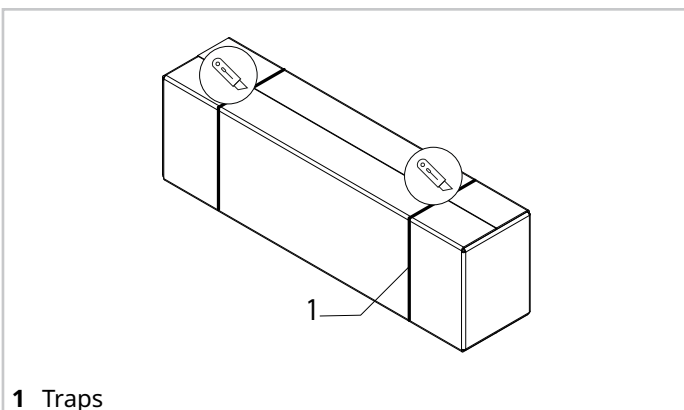

## 5. Installation

### 5.1 Prerequisites

- ⚠ This section is intended exclusively for the Installer.
- ⚠ Refer to the Technical data chapter for details.
- ⚠ The electrical system and its components must be designed by a qualified technician who must work according to the rules of good practice and national regulations.
- ⚠ The uncased additional practical cabinet for system accessories cannot replace the load-bearing wall, so it is mandatory to consult the building designer to ascertain the most suitable place to create the niche in the wall.
- ⚠ When creating the niche in the wall, never interrupt/cut piping, cables, drains of any type, etc., and especially reinforced concrete load-bearing structures.
- ⚠ **Ensure that:**
  - the room or the compartment is dry and the room temperature cannot fall below 0°C or rise above 35°C
  - any furniture or other objects can be moved easily in the event of maintenance
  - the location can be accessed safely
  - the clearances are guaranteed
  - the support surface or the wall can withstand the weight of the unit
  - the floor or wall section does not interfere with power lines or water piping and no load-bearing elements of the construction are compromised
- ⚠ **Avoid therefore:**
  - places that may be subject to flooding

### 5.2 General diagram

#### Installation of the uncased additional practical cabinet for system accessories.

See accessory sheet for installation.

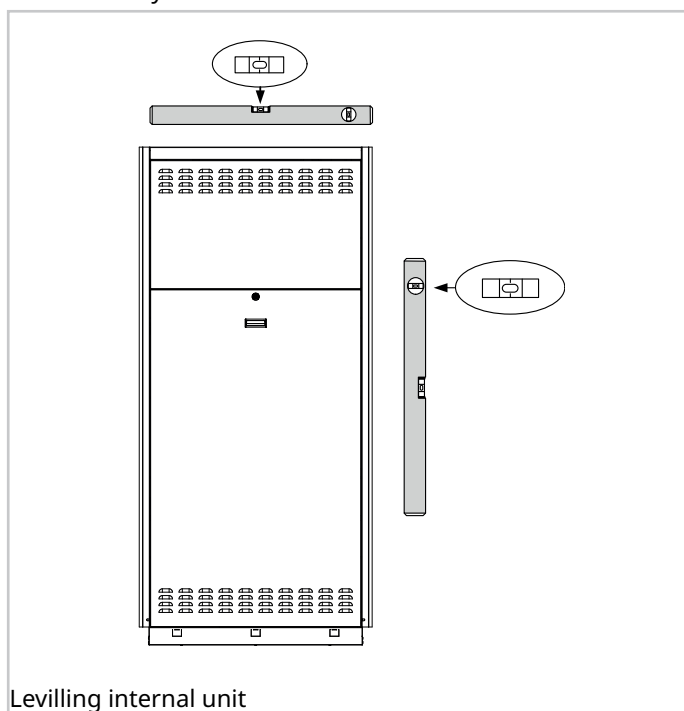

- ⚠ The front spaces can be occupied by furniture or other objects that must be easily removable in case of maintenance interventions.

## 5.3 Access to internal parts

The unit has removable access panels.

To access the unit:

- ▶ unscrew the locking screw

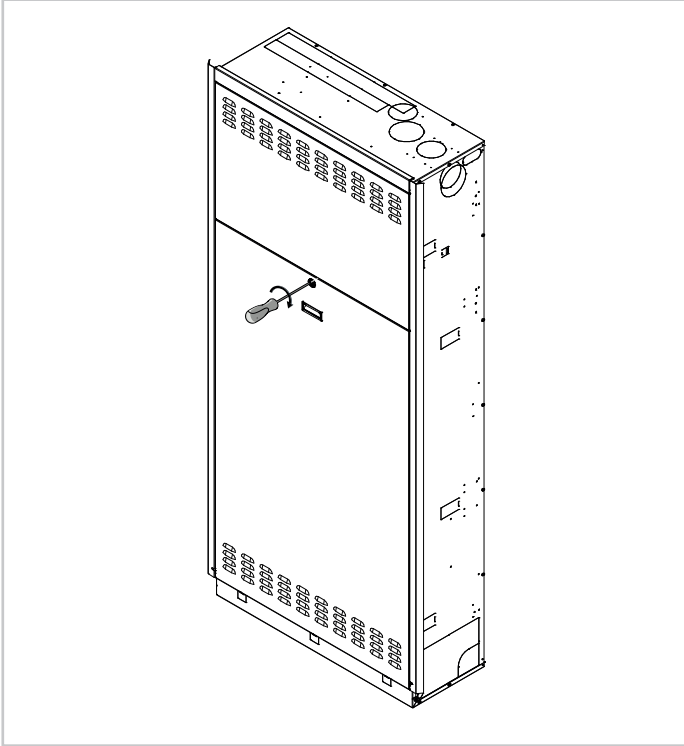

- ▶ remove the access panel

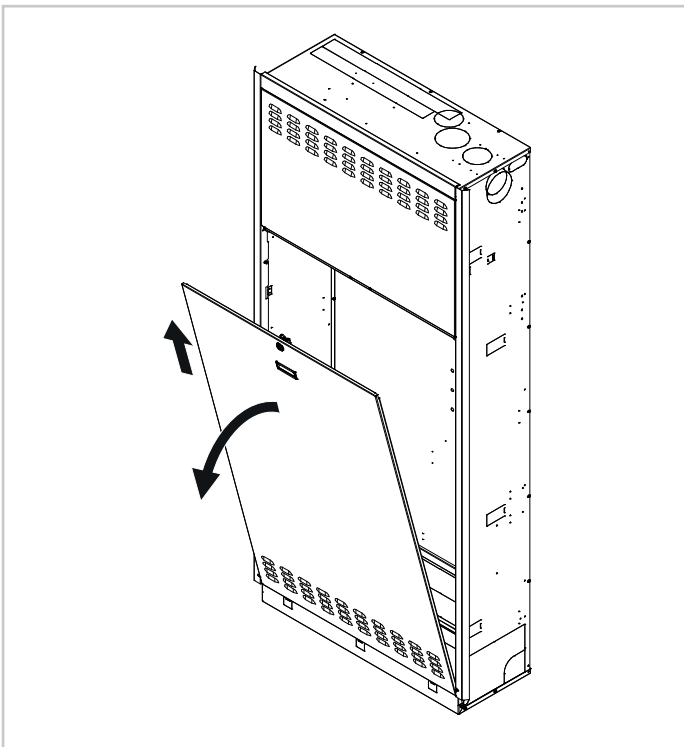

- ▶ unscrew the fixing screws
- ▶ remove the protection panel

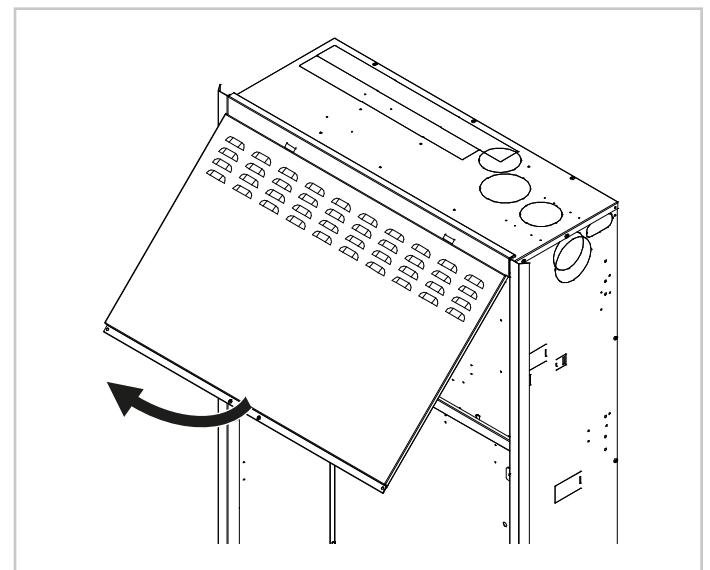
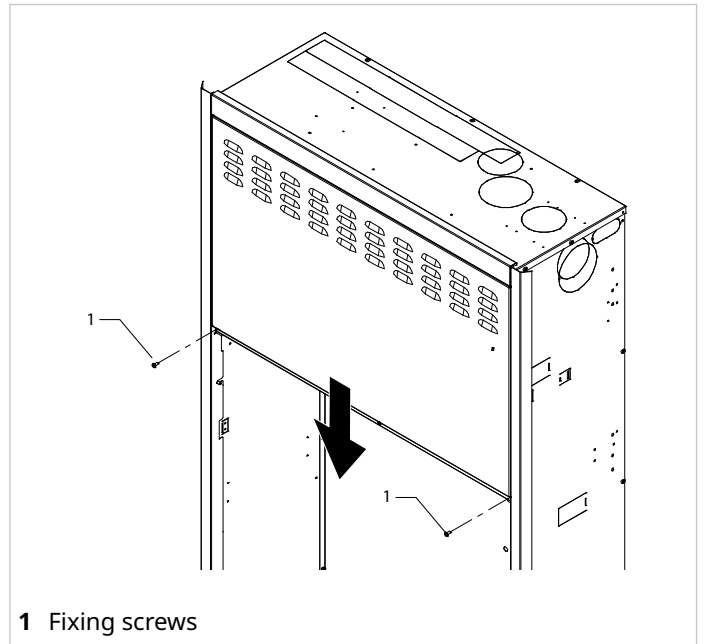

To refit:

- ▶ repeat the operations in reverse order

### 5.3.1 Access to the electrical panel

To access the electrical panel:

- ▶ unscrew the fixing screws
- ▶ cut the fastener

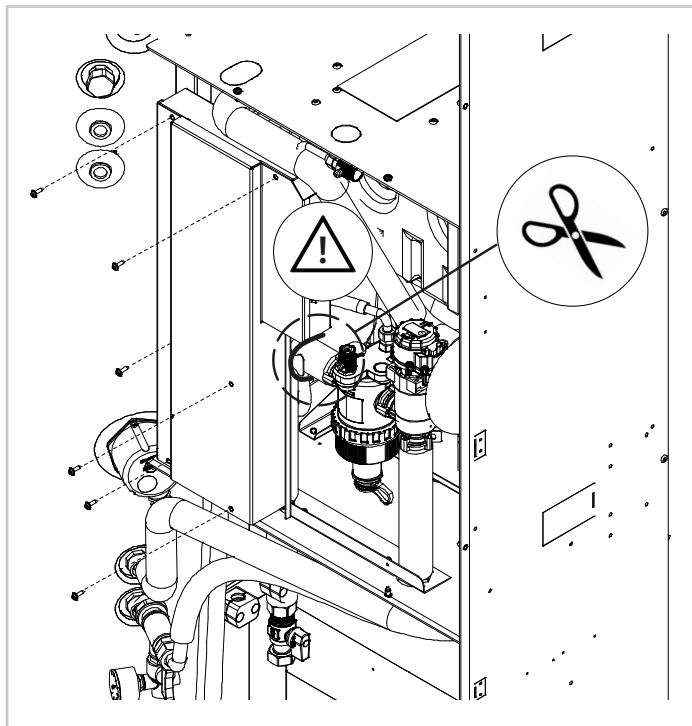

▶ remove the access panel

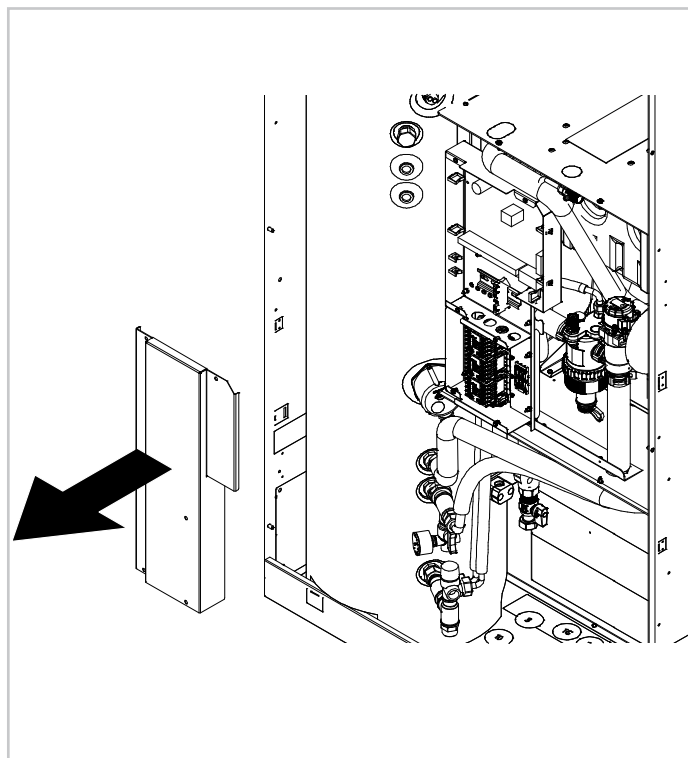

To access the components behind the electrical panel

▶ unscrew the screw

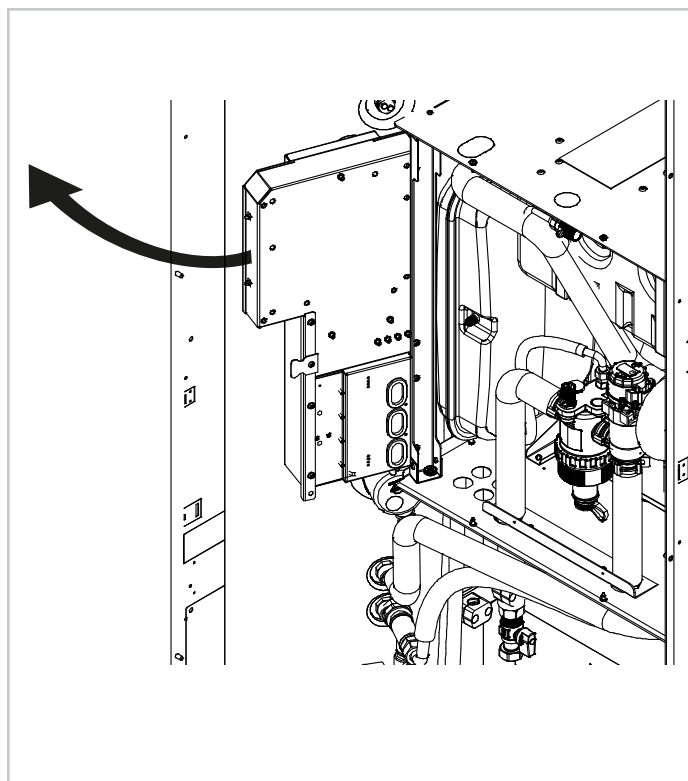
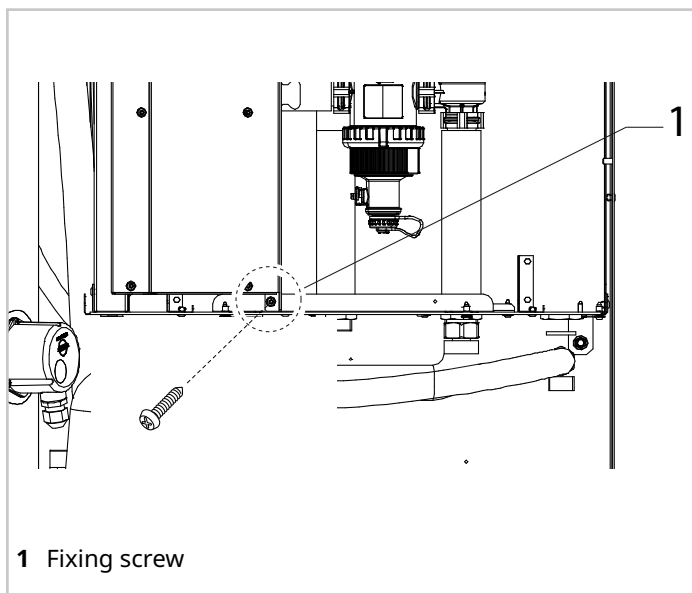



### 5.4 EASYBox module installation

**⚠** Ensure that:

- the DHW tank is installed first, see instructions for the separately supplied accessory.

**i** Use Teflon, liquid sealants, etc. to make threaded connections watertight.

**Assembly sequence:**

- ▶ remove the protection caps
- ▶ install the supports

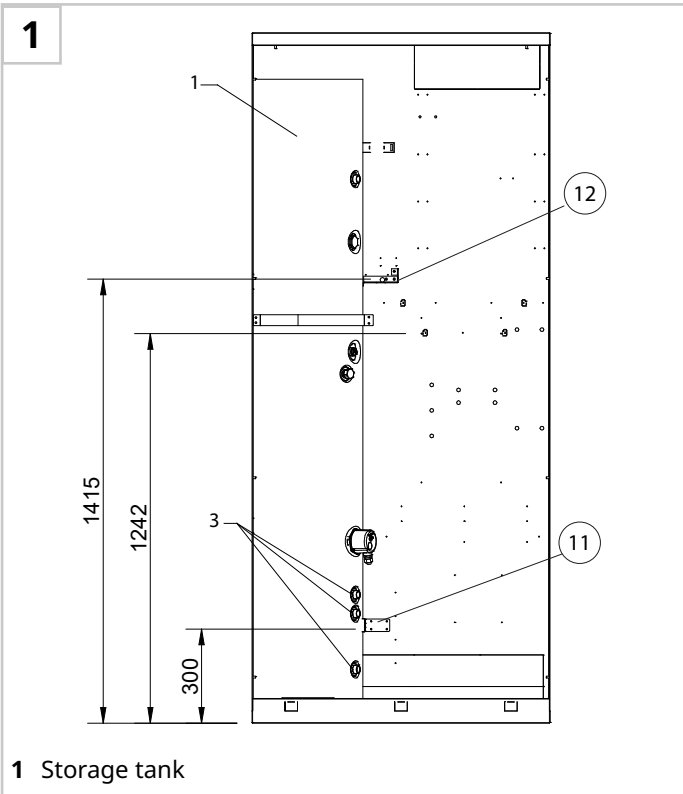

▶ open pre-cut areas

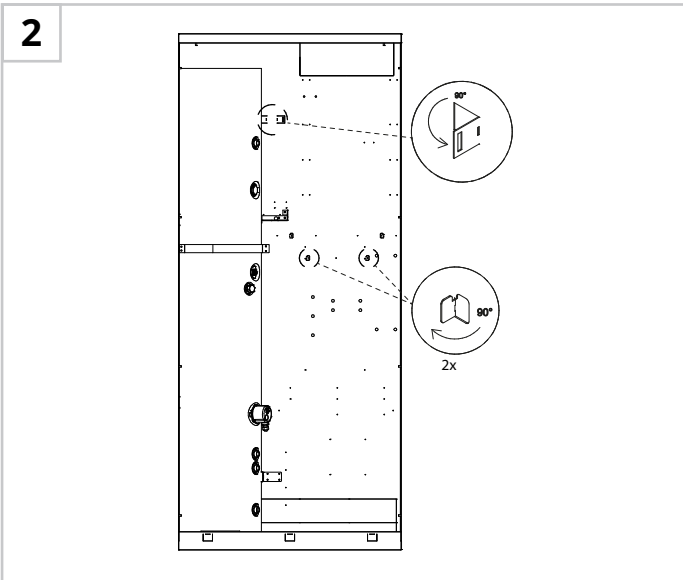

▶ install the hydronic module

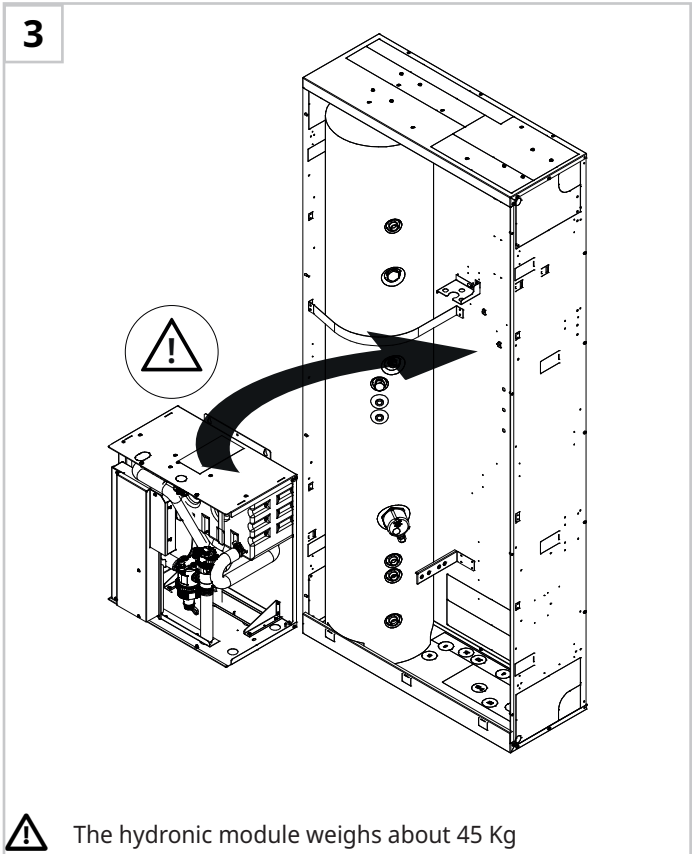

▶ fix the hydronic module with the screws

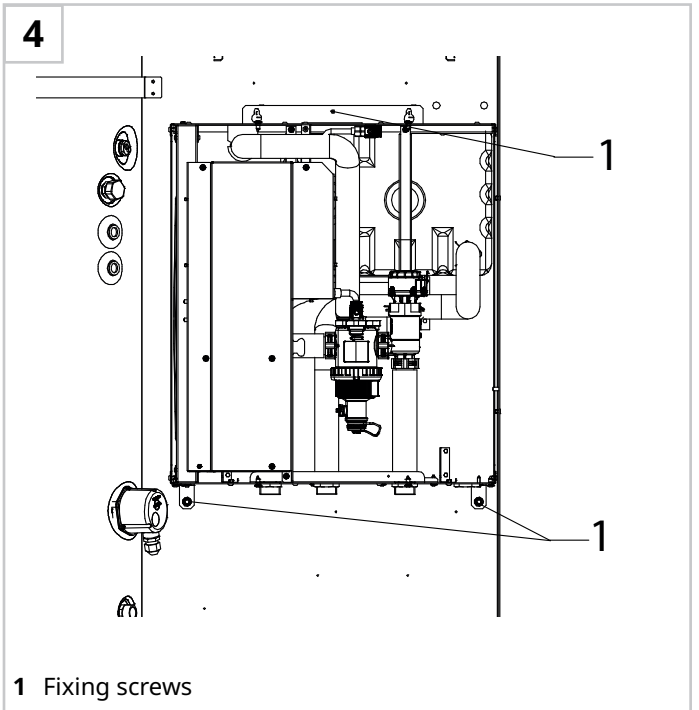

5.4.1 Installation of hydraulic components kit

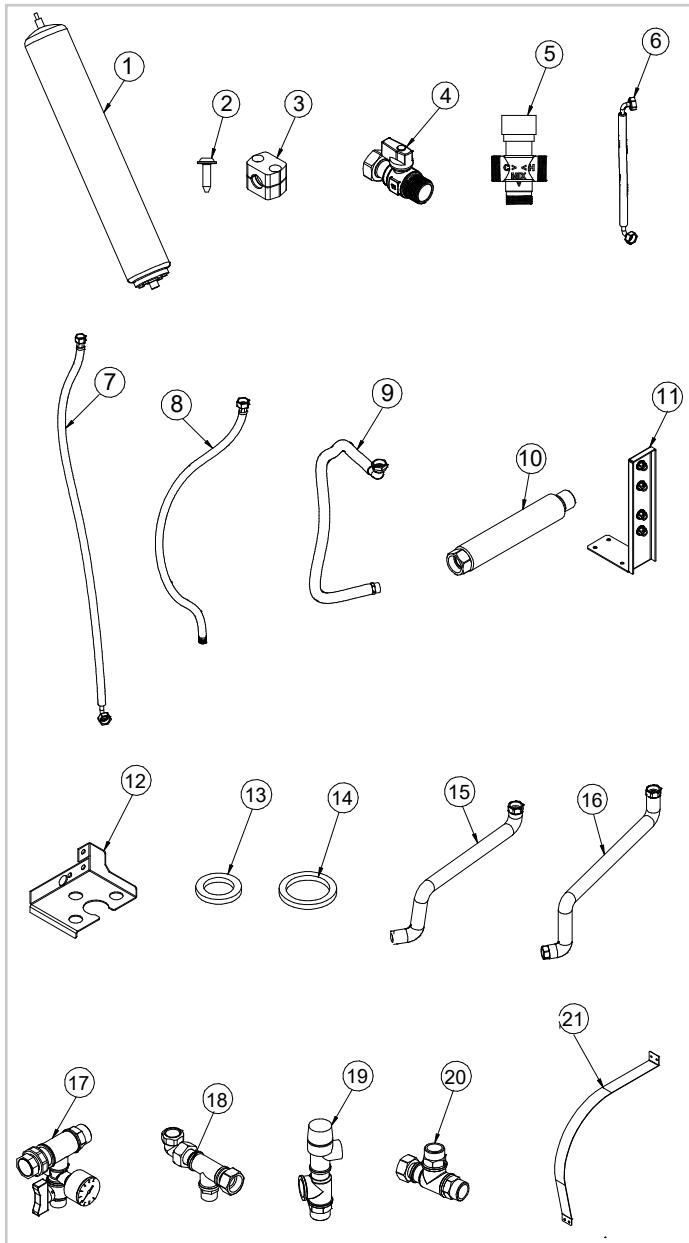

- ▶ install the expansion tank
- ▶ pass the pipe clamps through the slots to lock the expansion tank

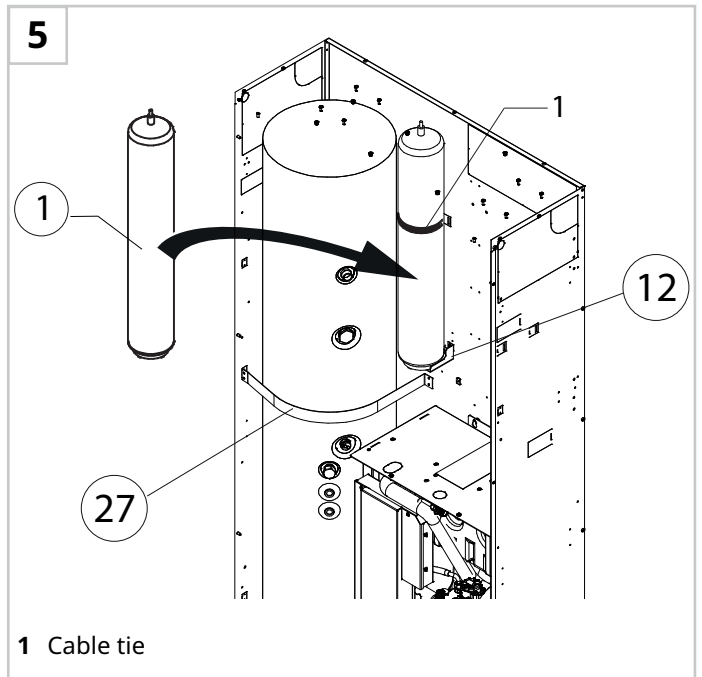

1 Cable tie

- ▶ install the fitting and pressure relief valve
- ▶ install the pipe with the tap

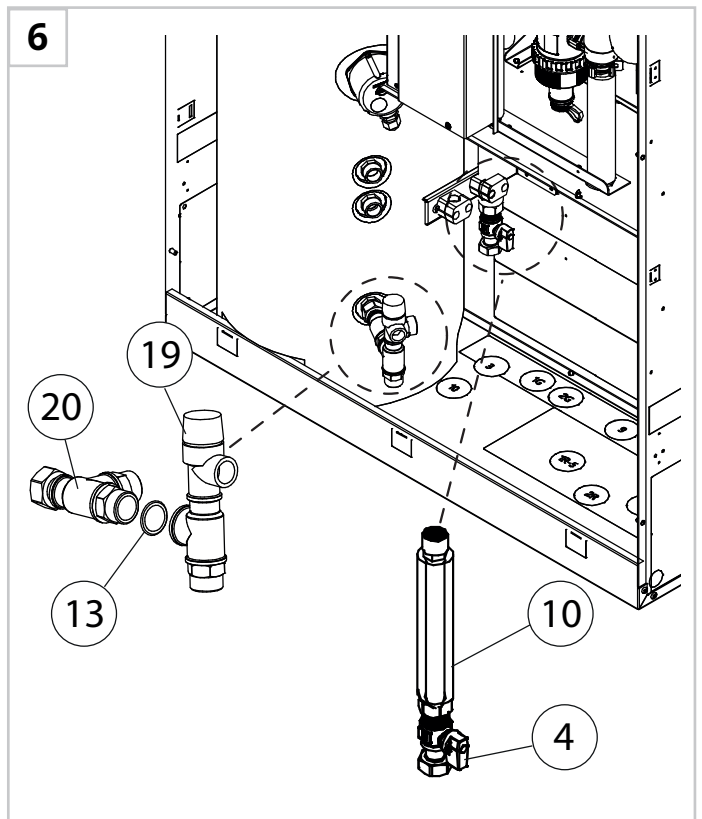

6

► clamp the pipe to the fixing bracket

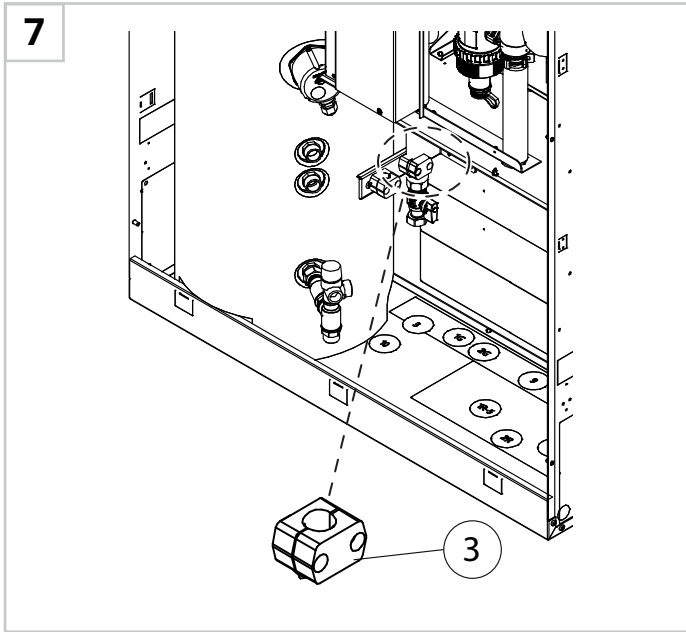

► install the DHW withdrawal pipe

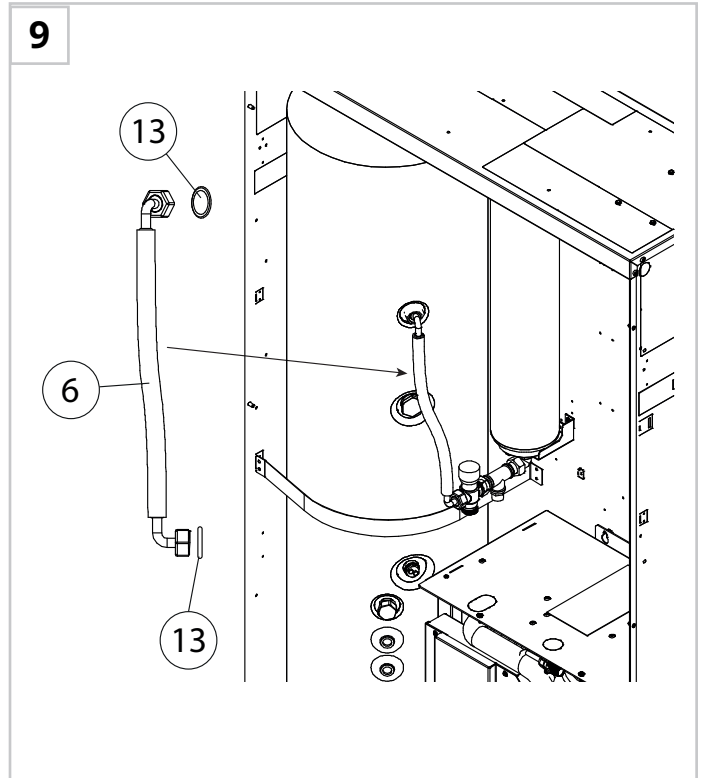

► install the pressure relief valve

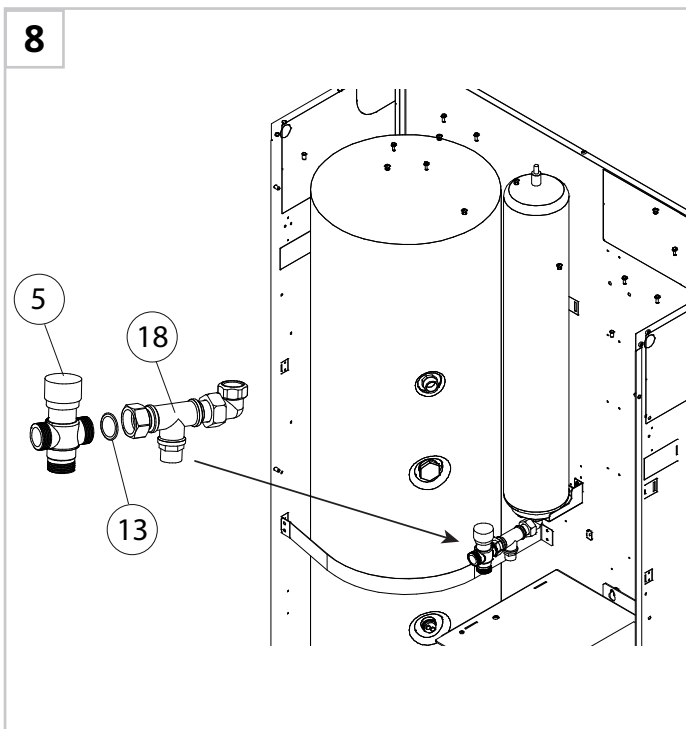

► install the water supply system inlet pipe

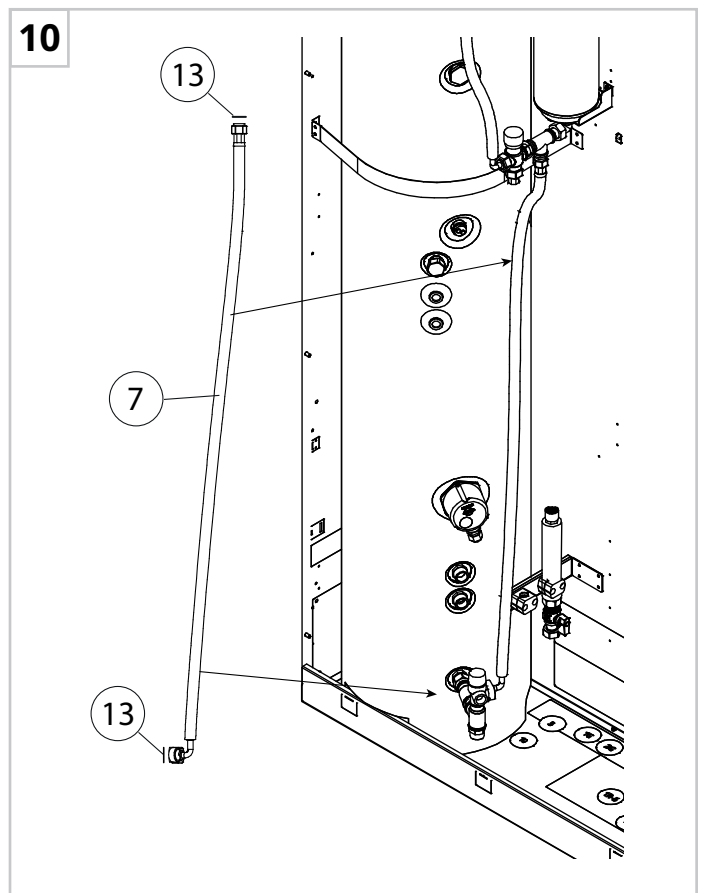

► install the DHW pipe

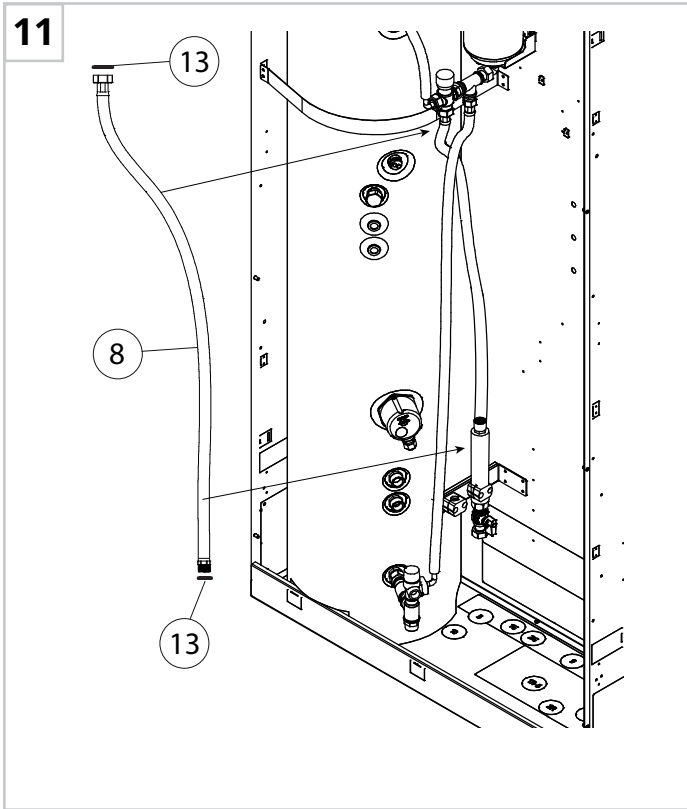

► install the supply pipe to outdoor unit

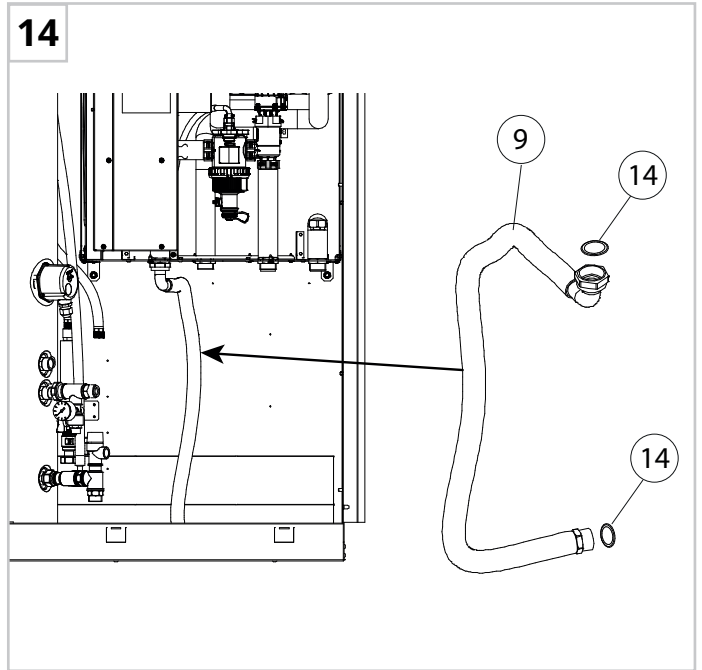

► install the system filling/refilling tap

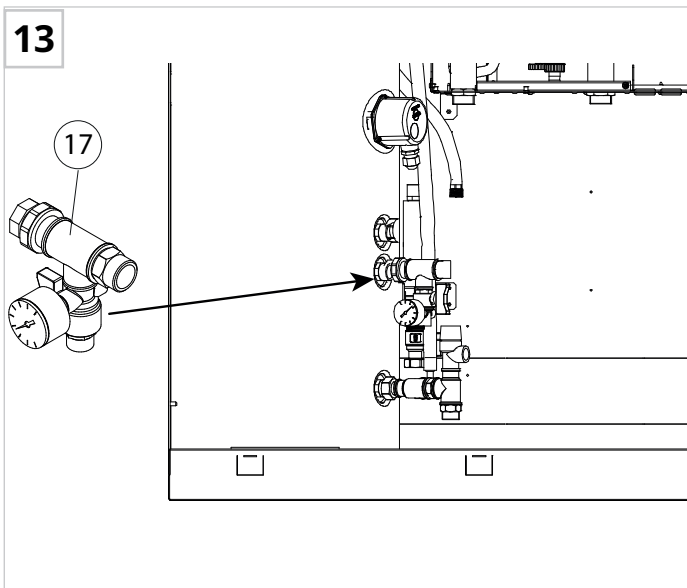

► install the DHW return pipe  
► install the DHW supply pipe

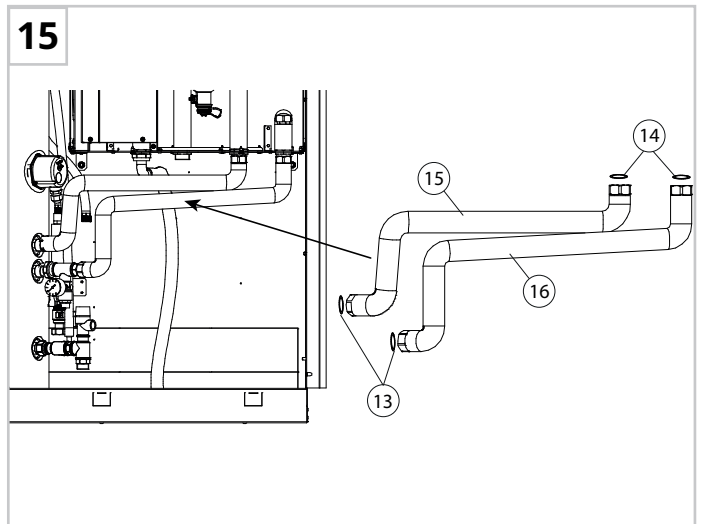

## 5.5 Additional aesthetic practical cabinet for system accessories in full view

### Option

- i** When the optional additional aesthetic practical cabinet for system accessories in full view is present, follow the installation instructions for the main components below.
- i** Use Teflon, liquid sealants, etc. to make threaded connections watertight.

### Assembly sequence:

- remove the protection caps

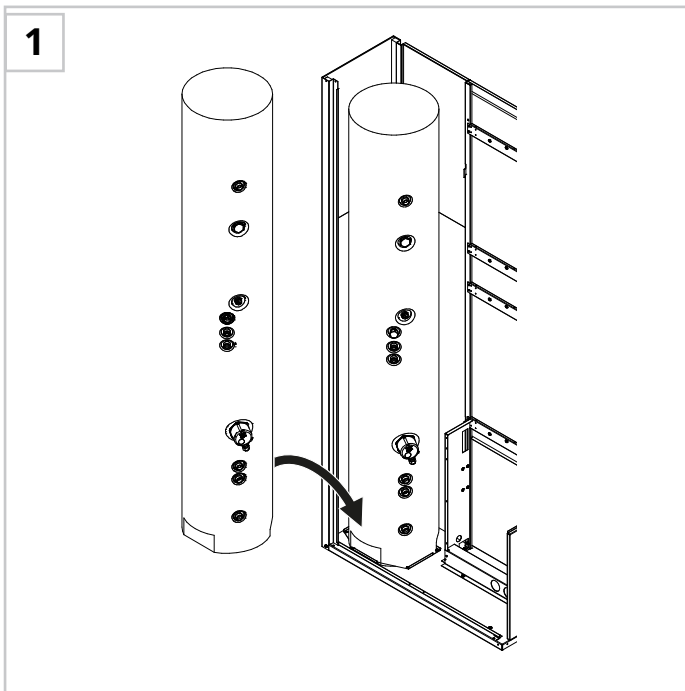

- install the mount

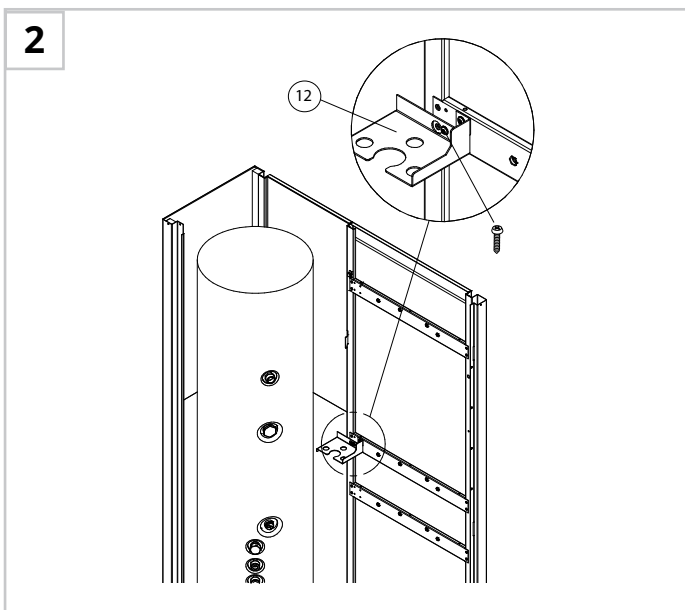

- install the hydronic module

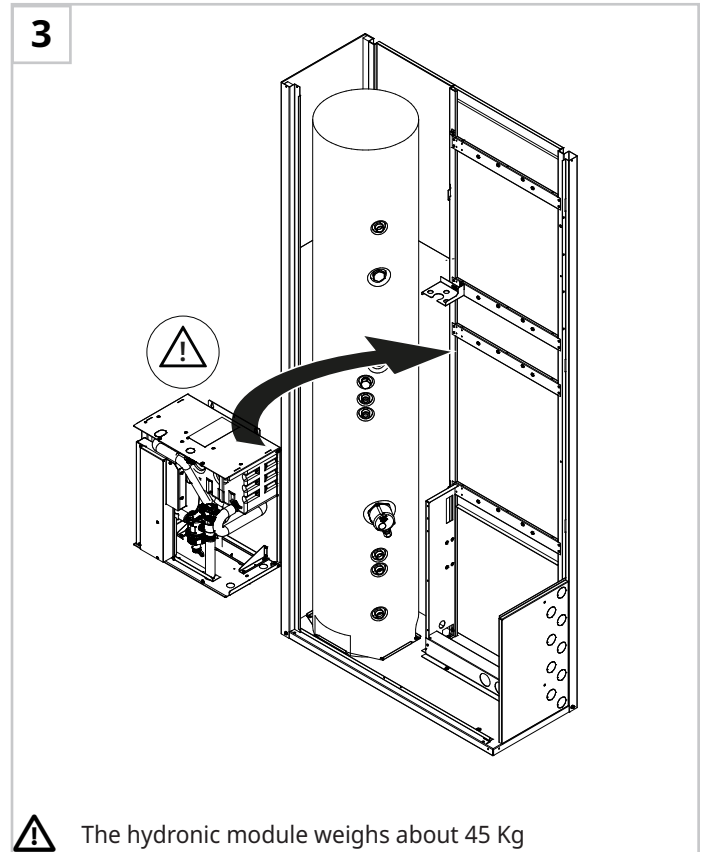

**!** The hydronic module weighs about 45 Kg

- fix the hydronic module with the screws

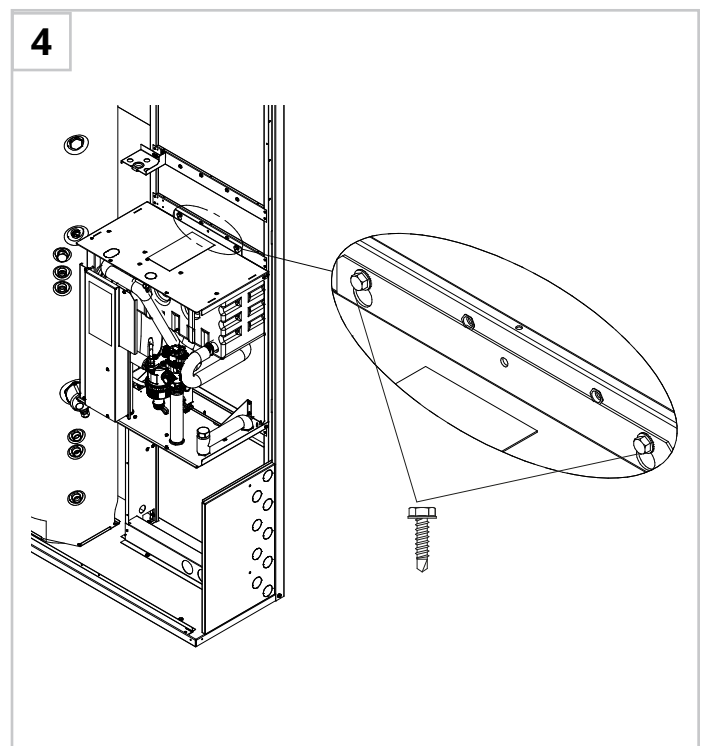

5.5.1 Installation of hydraulic components kit

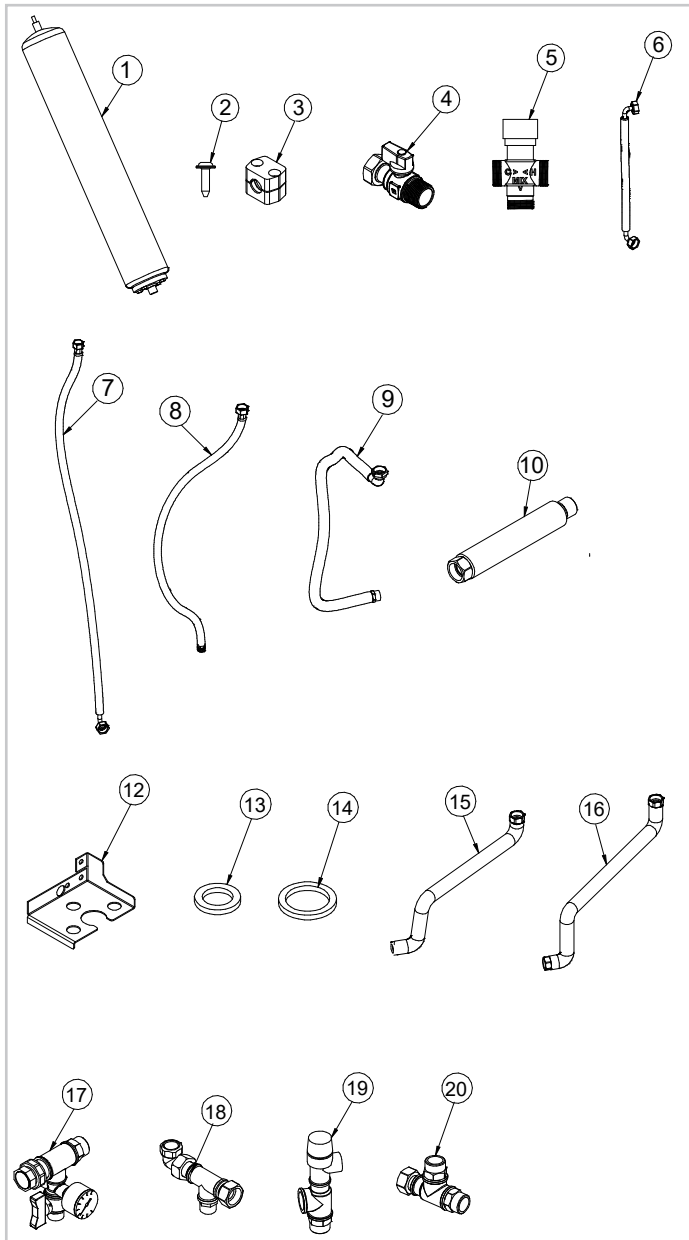

- ▶ install the expansion tank
- ▶ pass the pipe clamps through the slots to lock the expansion tank

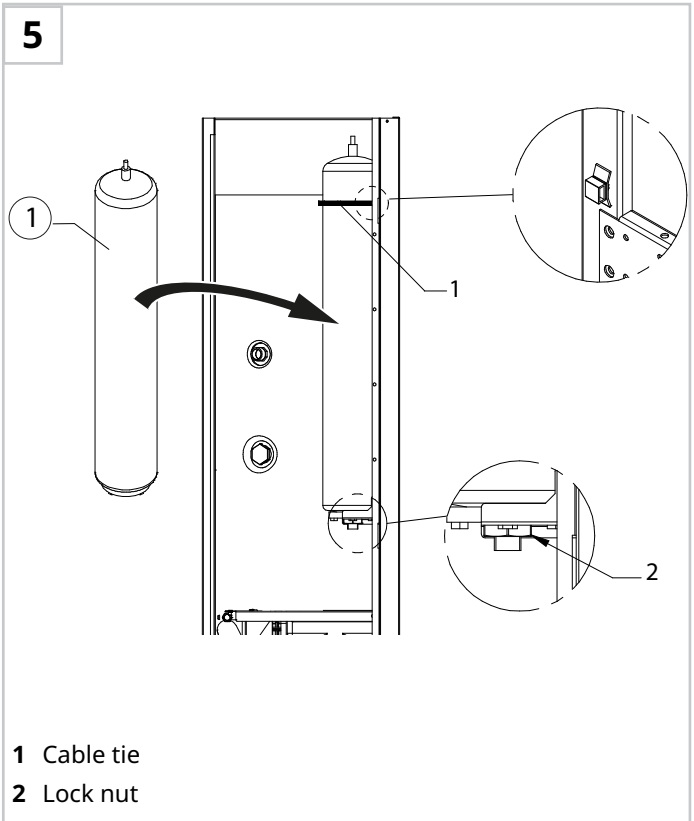

- 1 Cable tie
- 2 Lock nut

- ▶ install the fitting and pressure relief valve
- ▶ install the pipe with the tap

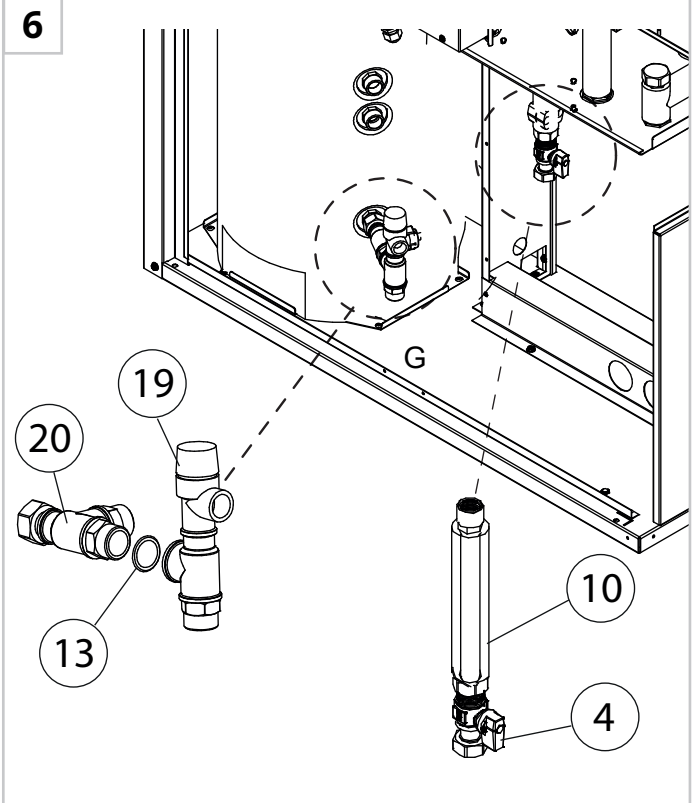
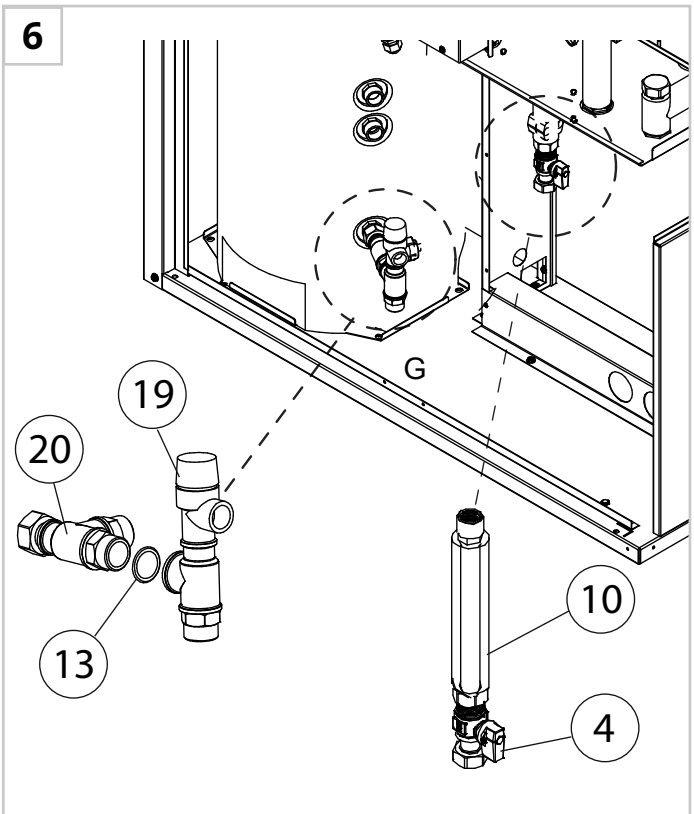

- 19
- 20
- 13
- 10
- 4

# Installation

► clamp the pipe to the fixing bracket

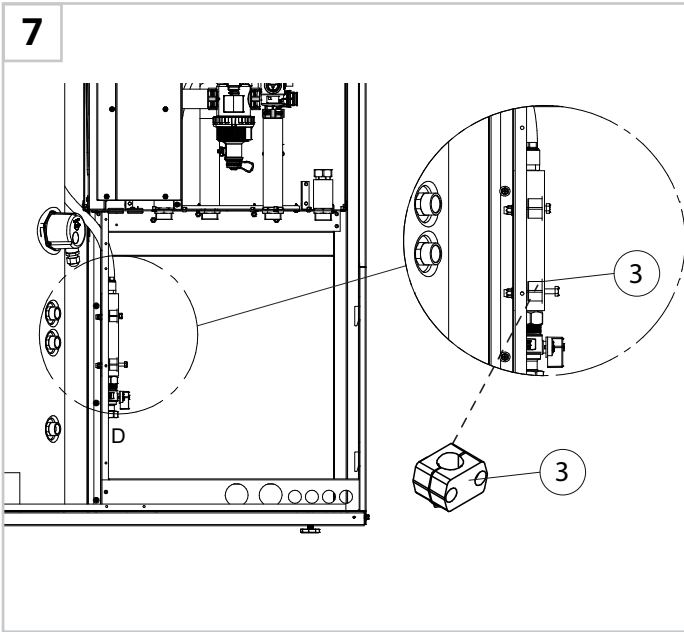

► install the pressure relief valve

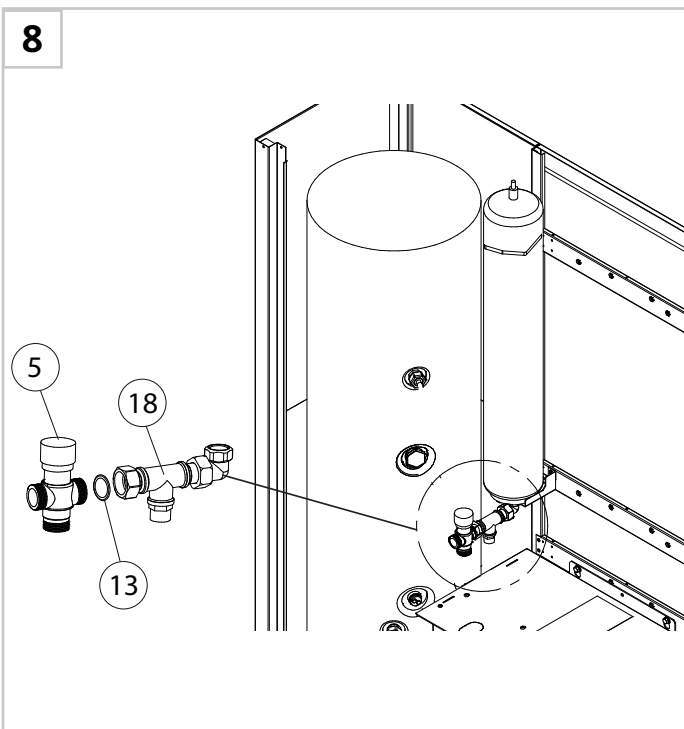

► install the DHW withdrawal pipe

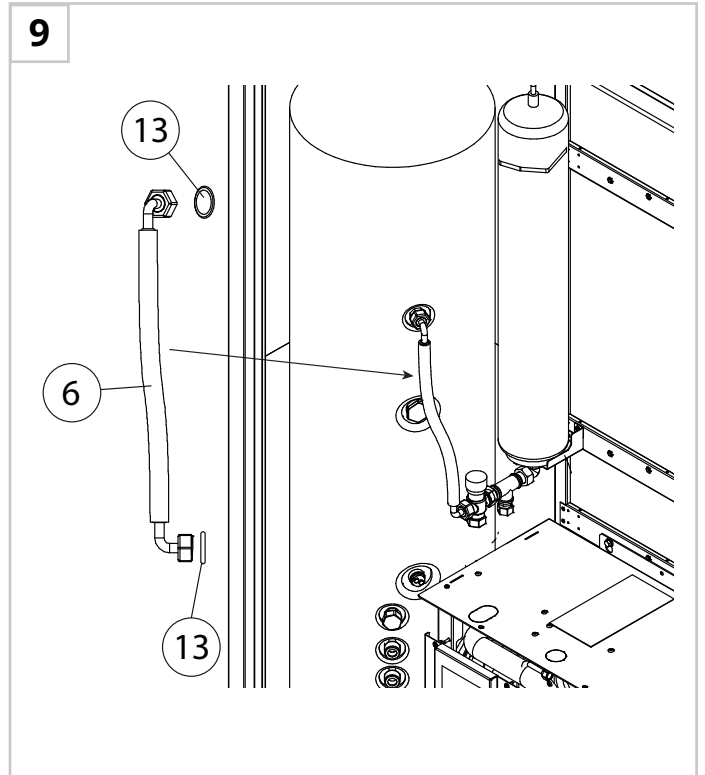

► install the water supply system inlet pipe

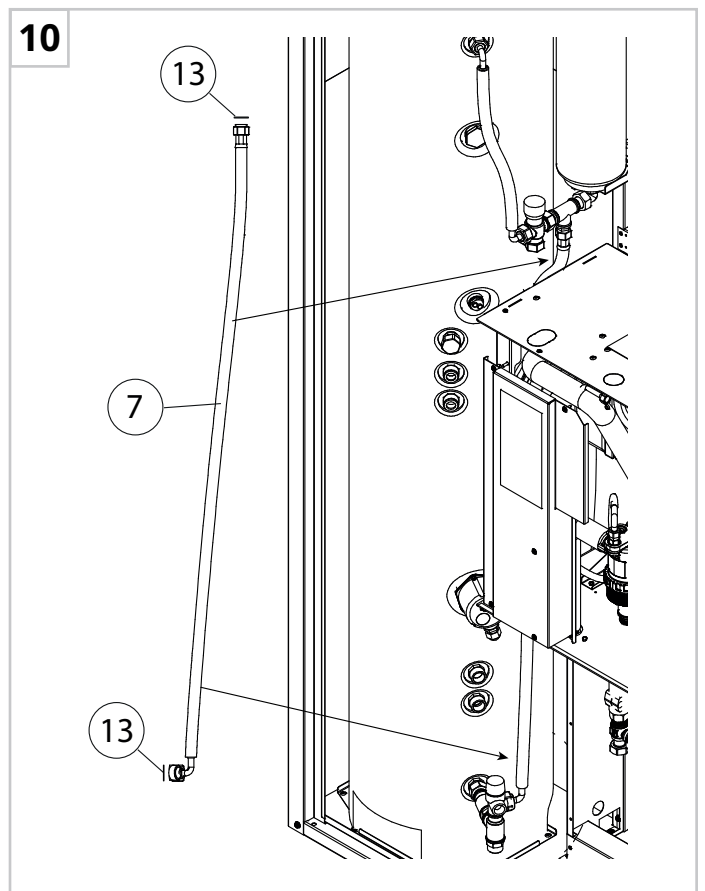

► install the DHW pipe

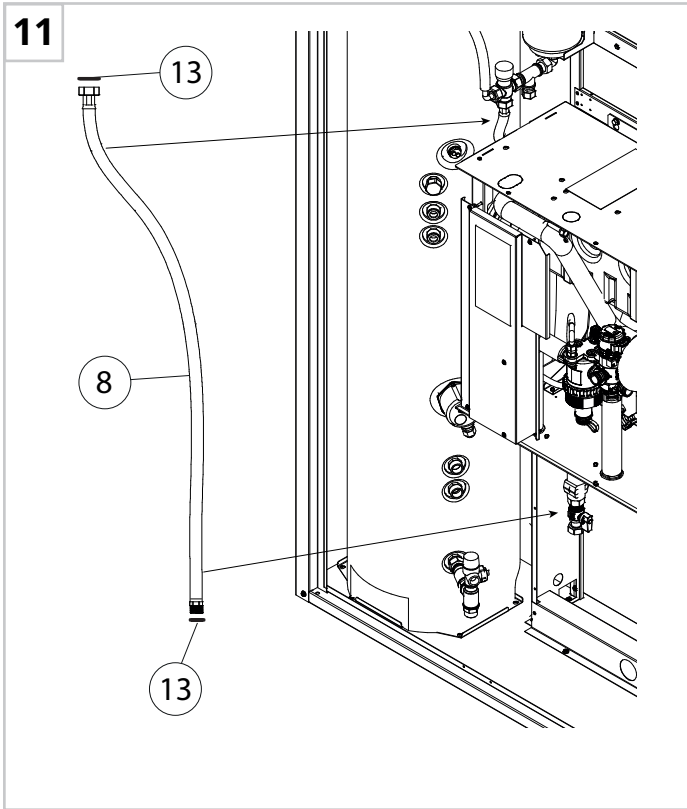

► install the supply pipe to outdoor unit

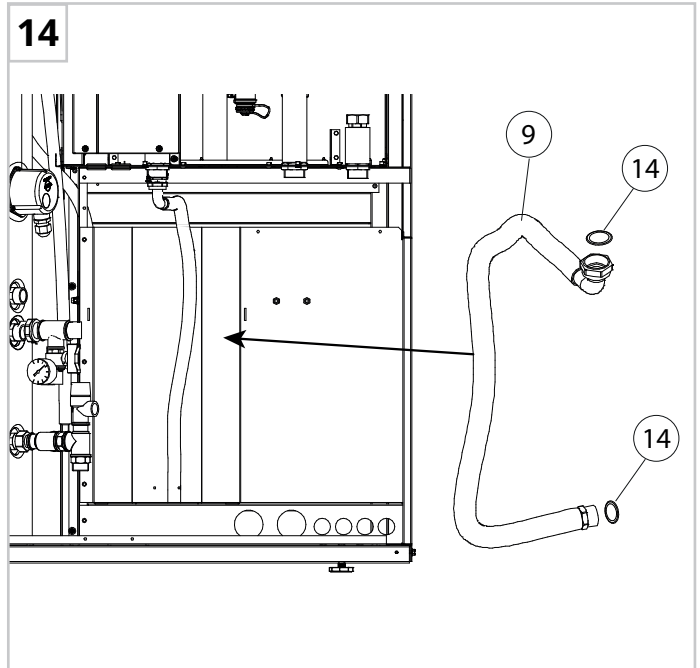

► install the system filling/refilling tap

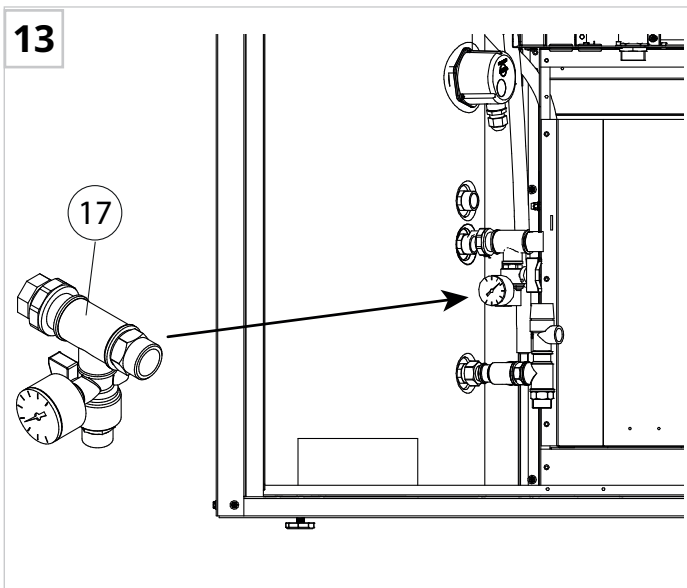

► install the DHW return pipe  
► install the DHW supply pipe

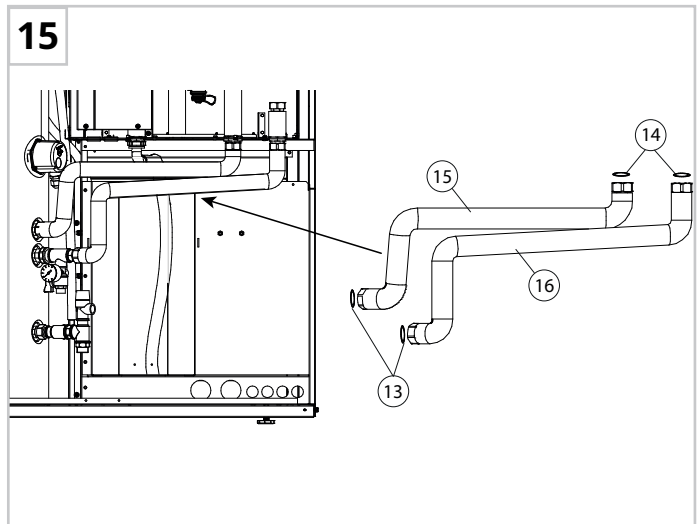

⚠ To complete the installation, see the instruction page for the Additional aesthetic practical cabinet for system accessories in full view.



## 6. Water connections

### 6.1 General system diagram

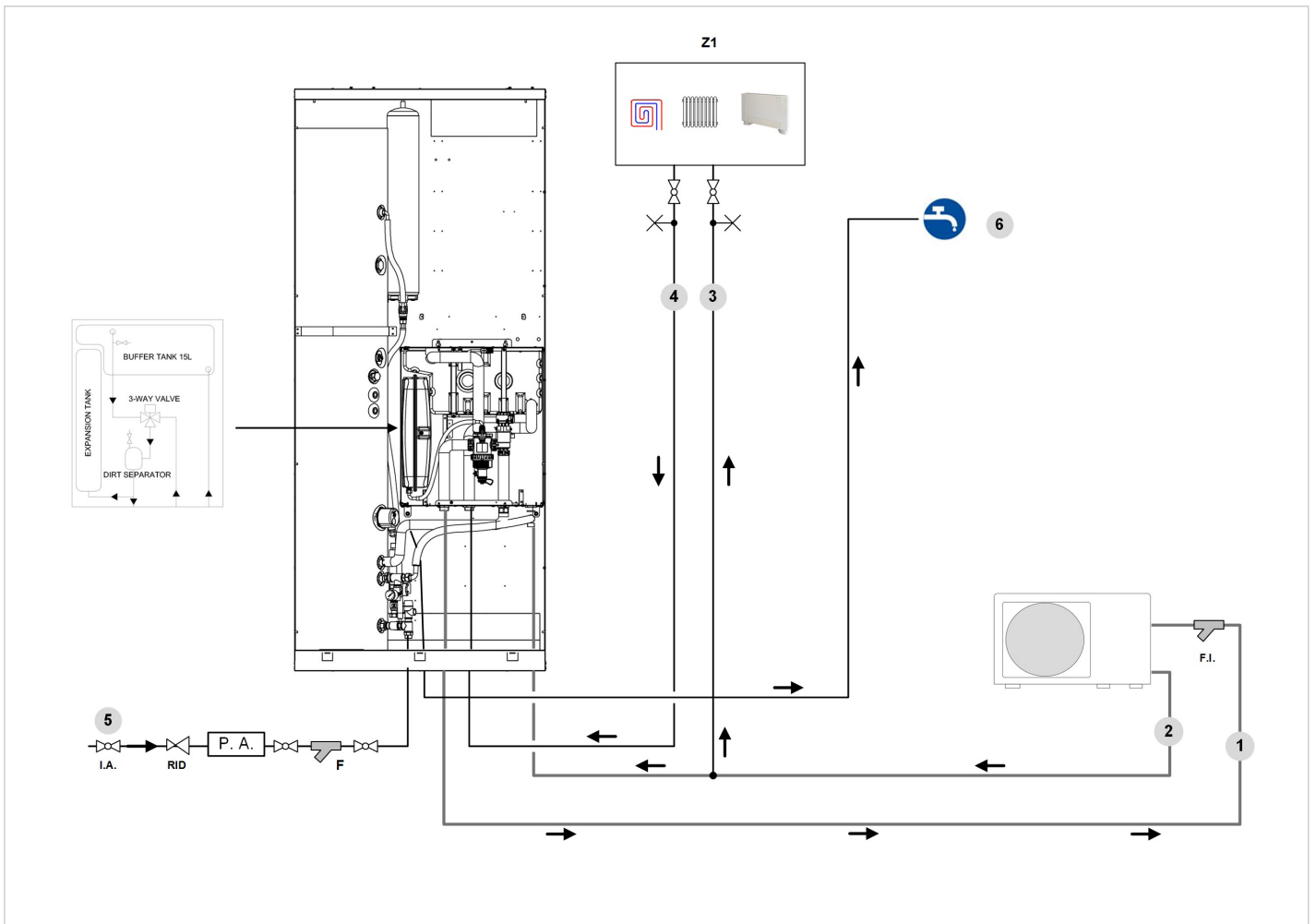

#### Indispensable components system (not supplied)

C.C.	<b>Components provided by Customer</b>	1	Water supply to outdoor packaged unit
I.A.	Aqueduct inlet	2	Water return to outdoor packaged unit
F	Water filter (to be provided by customer)	3	System outlet
F.I	System filter (standard supplied)	4	System return
P.A	Descaler protection	5	Aqueduct inlet
RID	Pressure reducing valve	6	DHW outlet
Z1	Zone 1		Vent
			Cut-off valves
			Anti-vibration joints

**i** Refer to the combined outdoor unit manual for:

- Prerequisites
- Water flow-rate
- Minimum water content
- Water characteristics
- Cleaning
- Piping insulation
- Hydraulic circuit antifreeze protection

**6.2 Position of connections**

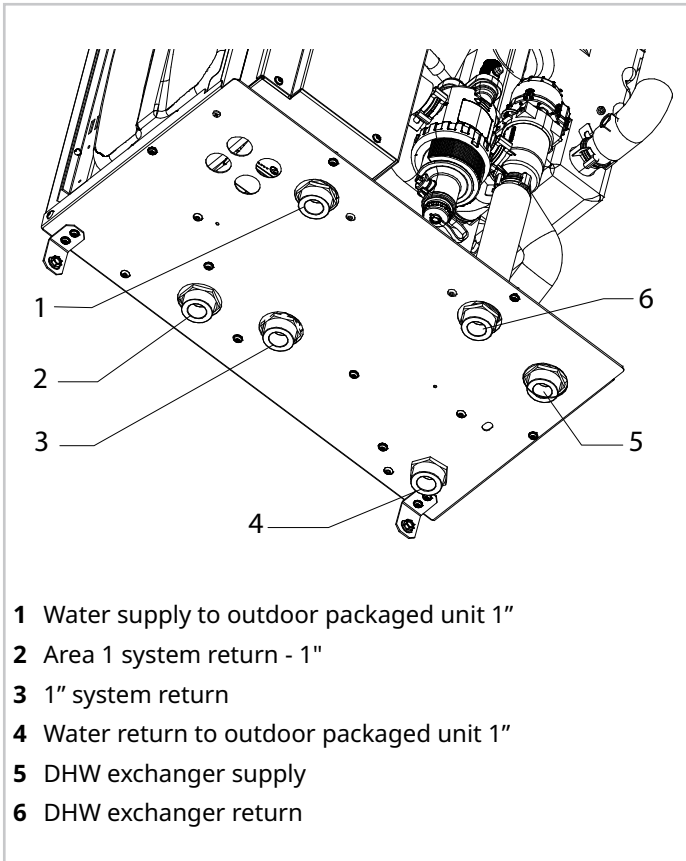

**6.3 Hydraulic connection**

**Ensure that:**

- clean piping with no moisture, air, dirt or dust is used
- the end of the pipe is kept downwards when removing burrs
- the end of the pipe is covered when passing it through a wall to prevent dust and dirt from entering
- thread sealant is used to seal the connections that must withstand the pressures and temperatures of the circuit
- the two types of materials are isolated from each other to prevent galvanic corrosion when using non-copper metal piping
- the piping is not deformed by using excessive force or unsuitable tools during connection: this could cause the unit to malfunction.

**!** Always use the wrench and counter wrench method in tightening operations.

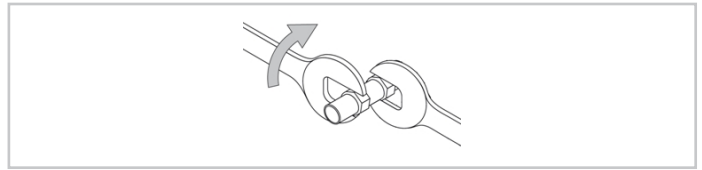

**6.4 Water filter**

- !** Supplied with the outdoor unit.
- !** Installation of the filter is mandatory.
- !** Operation without a filter can cause irreversible damage to the unit.
- !** Operation without a filter will void the warranty.

**Remember that the filter must be:**

- installed immediately at inlet to the water supply system
- easily accessible for maintenance work
- !** Periodically check for clogging.
- ⊖** The filter should never be removed.

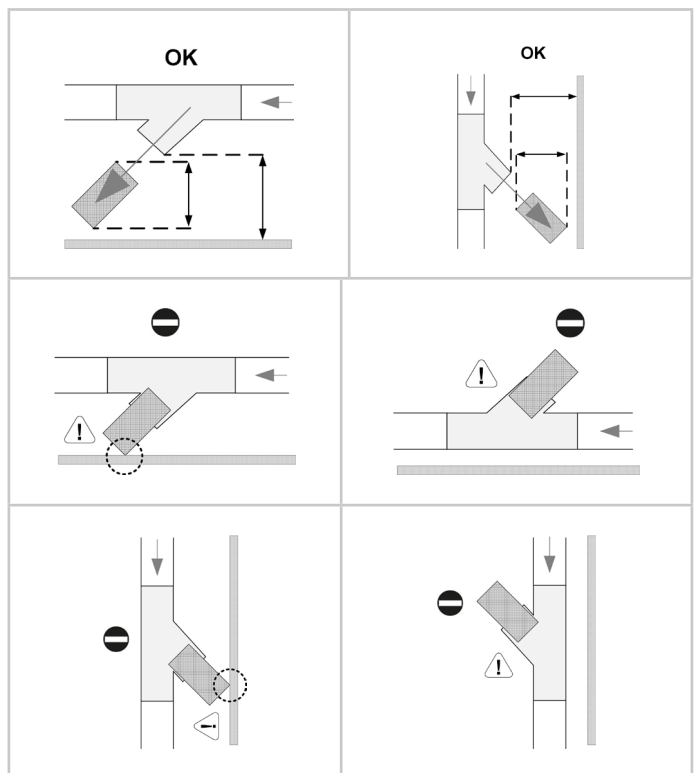

### 6.5 DHW safety valve

- ⚠** Inside the unit there is a safety valve (6 bar on the DHW circuit) that must be connected to a suitable drain, otherwise if valves intervened and flood the rooms, the heat pump manufacturer will not be responsible.

#### Pressure relief valve connection

- ▶ connect the pipe to the pressure relief valve
- ▶ direct the exhaust pipe towards a suitable drain

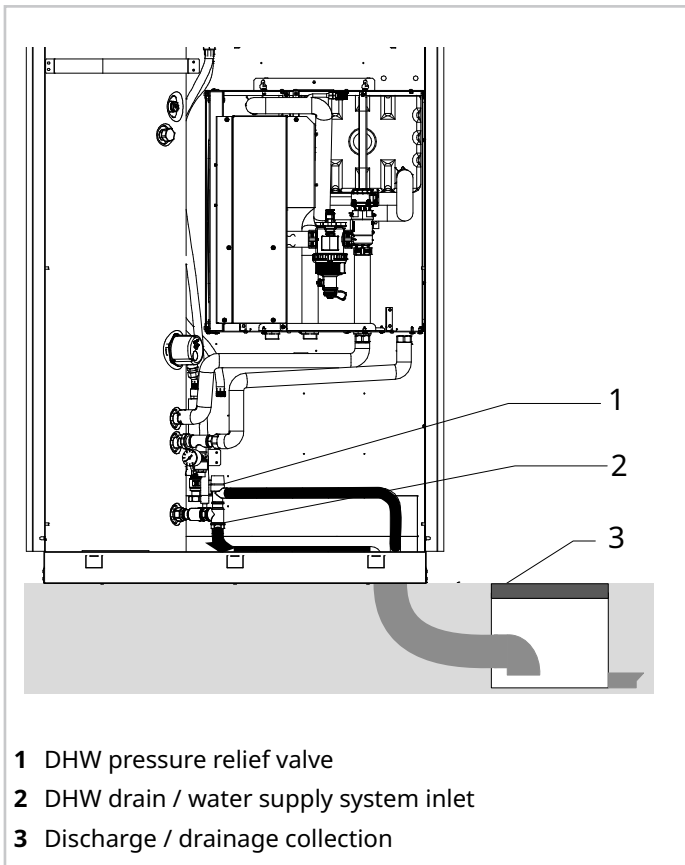

### 6.6 DHW tank filling

Once the hydraulic connections have been completed, the DHW tank can be filled.

#### DHW tank filling:

- ▶ system's main switch OFF
- ▶ close the DHW drain tap
- ▶ start filling, open the filling tap on the system (refer to the General system diagram)
- ▶ open the DHW outlet tap
- ▶ open the hot water taps (bathroom and kitchen)

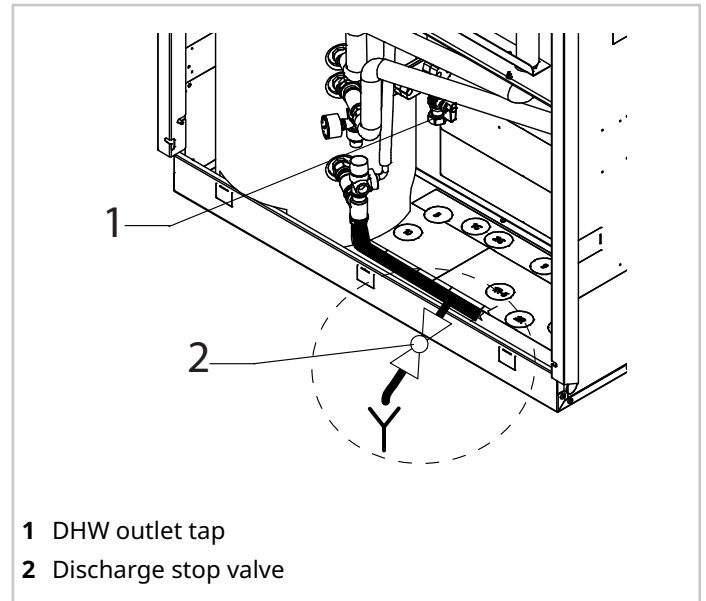

#### When water starts coming out of the taps:

- ▶ close the taps
- ▶ continue filling up to the system pressure value
- ▶ check the hydraulic seal of the joints

**⚠** Maximum DHW system pressure 6 bar

**⚠** DHW safety valve setting 6 bar

## 6.7 Loading the plant

Once the hydraulic connections have been completed, the system can be charged.

### Charging the system:

- ▶ open the system filling tap
- ▶ open the taps on the system (refer to the General system diagram)
- ▶ open all of the system and terminal relief valves

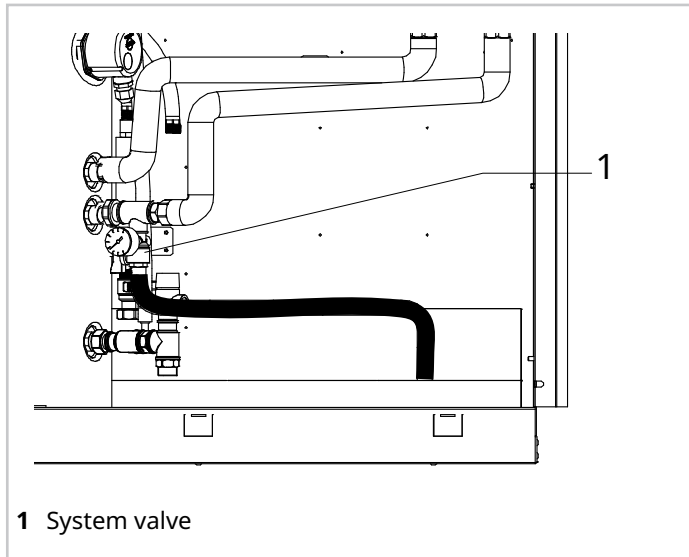

- ⚠ If the system remains charged and inoperative at outside temperatures close to zero, freezing problems may occur.
- ⚠ Refer to the Hydraulic Circuit Frost Protection chapter.
- ⚠ In case of extraordinary maintenance see chapter MAINTENANCE.

### When water starts coming out of the air relief valves:

- ▶ close the valves
- ▶ continue filling up to the system pressure
- ▶ check the hydraulic tightness of the connections.

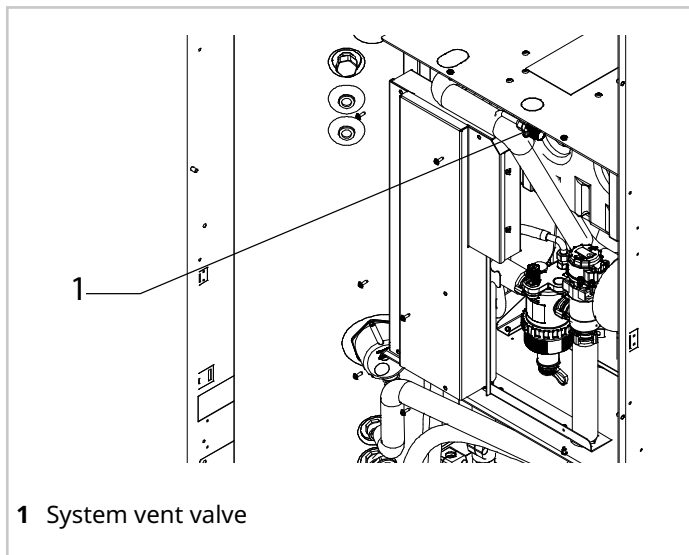



























Repeat this operation after the unit has been operating for a few hours.

- ⚠ Check the system pressure periodically.
- ⚠ Reintegration is carried out when the unit is off (pump OFF).

## 7. Electrical connections

### 7.1 Prerequisites

-  This section is intended exclusively for the Installer.
-  The electrical system and its components must be designed by a qualified technician who must work according to the rules of good practice and national regulations.
-  All electrical operations should be performed by trained personnel having the necessary requirements by the regulations in force and being informed about the risks relevant to these activities.
-  Operate in compliance with safety regulations in force.
-  The power cables and the protection cable section must be defined in accordance with the characteristics of the protections adopted.
-  The protection devices of the unit power line must be able to stop the presumed short circuit current, whose value must be determined in function of system features.
-  Refer to the unit electrical diagram (the number of the diagram is shown on the serial number label).
-  verify that the network has characteristics conforming to the data shown on the serial number label.
-  Before starting work, verify that the sectioning device at the start of the unit power line is open, blocked and equipped with cartel warning.
-  The supply line must be disconnectable from the rest of the building's power mains with an all-pole magnetothermic circuit breaker with separation of contacts on all poles, to be implemented in accordance with current laws and regulations.
-  The protection must be sized in accordance with the electrical data declared by the manufacturer.
-  Disconnect the power supply before making any connection.
-  Do not crush cable bundles and prevent them from coming into contact with piping and any sharp edges.
-  Primarily you have to realize the earthing connection.
-  Incorrect grounding may cause electric shocks.
-  All external high voltage loads, if connected to a metal fitting or grounding clip, must be earthed.
-  The current required for each external load must be less than 0.2 A. If the current required for a single load is greater than 0.2 A, insert a contactor for control.
-  Install an earth leakage breaker (30 mA).
-  Failure to observe this precaution may result in electric shocks.
-  Power and signal cables should be routed as separately as possible to avoid any interference.
-  Keep the unit's controller wiring as far away from hot surfaces as possible. It is advisable to use cables with cross-linked polyvinyl chloride sheath.
-  For the electrical connection, use a cable of sufficient length to cover the entire distance without any connection work. Do not use extension cords. Do not apply other loads on the power supply.
-  If the power cable is damaged, it must be replaced by qualified personnel and in accordance with current national regulations.
-  The manufacturer is not liable for any damage caused by failure to install a grounding system or failure to comply with the diagrams.
-  Check the voltage values which must be within the limits: 220-240V +/- 10% and 380-415V +/- 6%.
-  Before power the unit, make sure that all the protections that were removed during the electrical connection work have been restored.
-  It is forbidden to connect the earth wire to gas or water pipes, lightning rods or telephone ground.

## 7.2 Cable inlet

To access the panel, see the "Access to internal parts" section

**⚠** Before removing the panel from the electrical panel, disconnect the power supply to the indoor and outdoor units and to all the other electrically powered components.

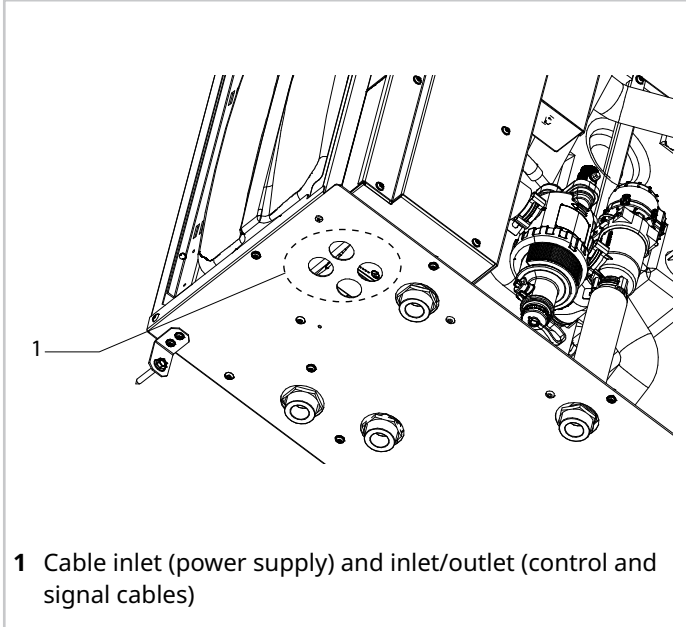

### Cable entry in the electrical panel

The connection cables are plugged into the back of the electrical panel.

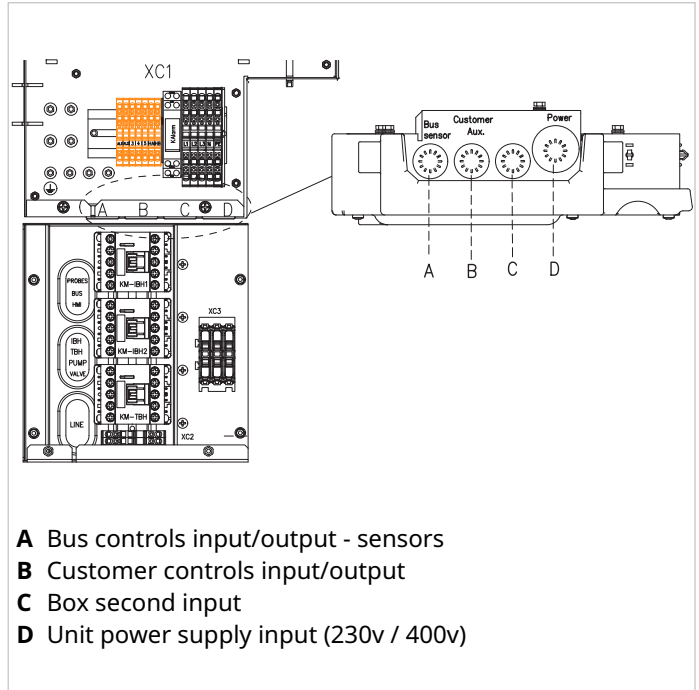
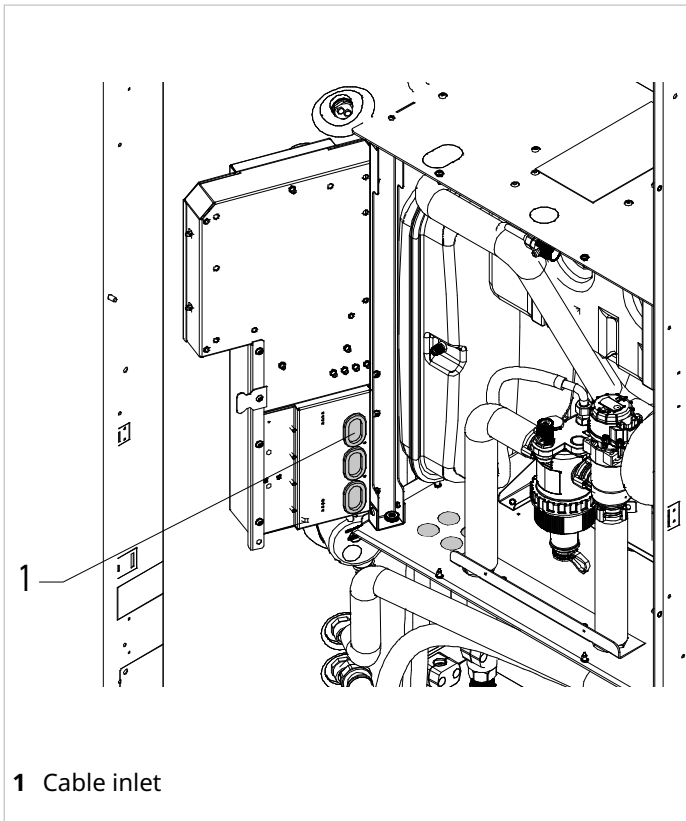

**⚠** Installations with domestic hot water tank (available as an option) and external backup heater require a dedicated electric circuit for the booster heater. See the accessory sheet for the domestic hot water tank.

**⚠** Connect as shown in the wiring diagrams.

### 7.3 Connecting the power supply

**⚠ Ensure that:**

- no cables of different cross-sections are connected to the same power supply terminal block (loosening of the power supply wires could cause overheating)
- terminal block screws are not over-tightened
- an earth leakage breaker and a fuse or magnetothermic circuit breaker are connected to the supply line.
- leave the power supply cable long enough for the electrical panel to be opened.

#### 7.3.1 Single-phase units

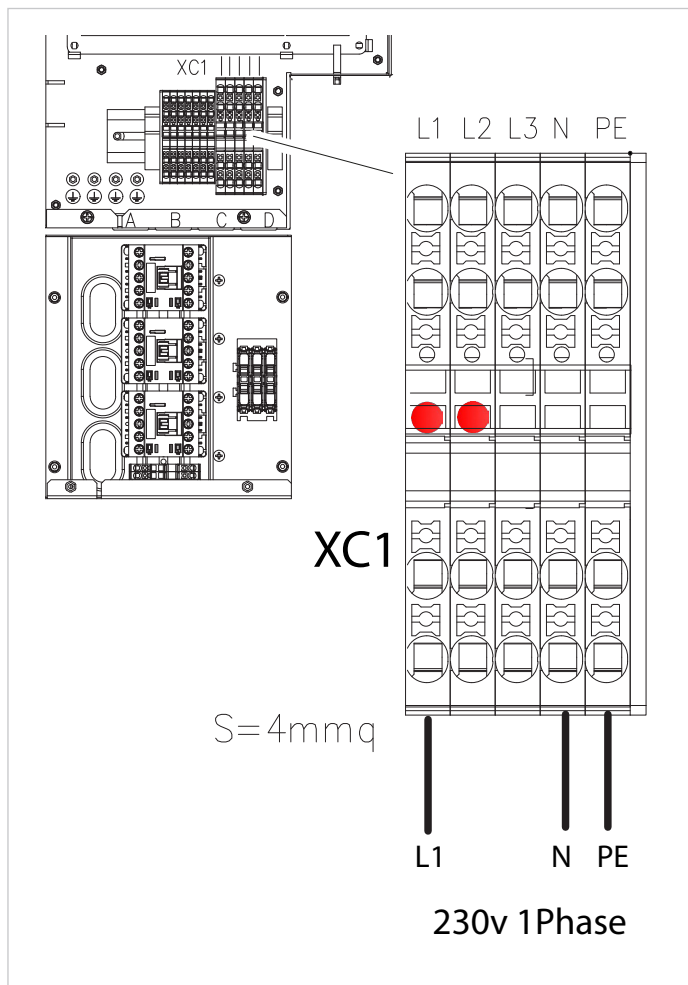

#### 7.3.2 Three-phase units

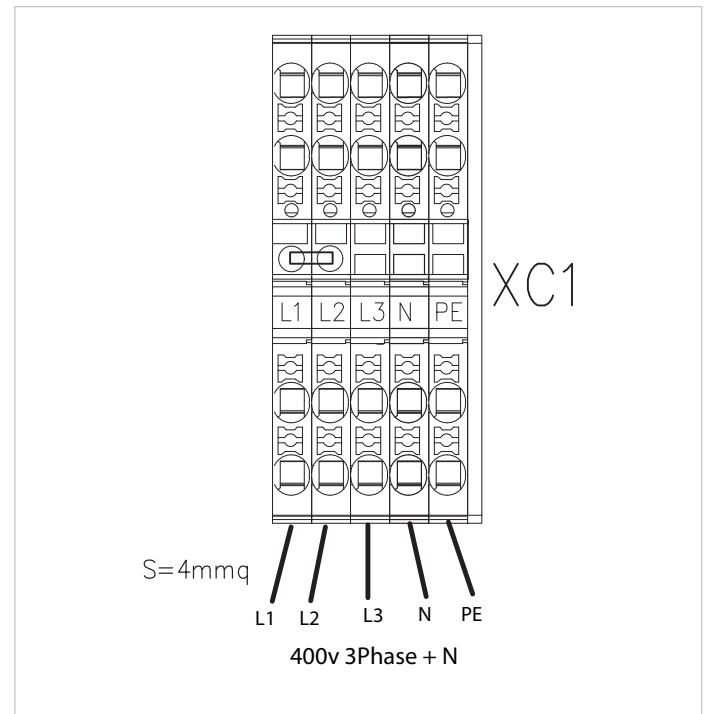

## 7.4 External component connections

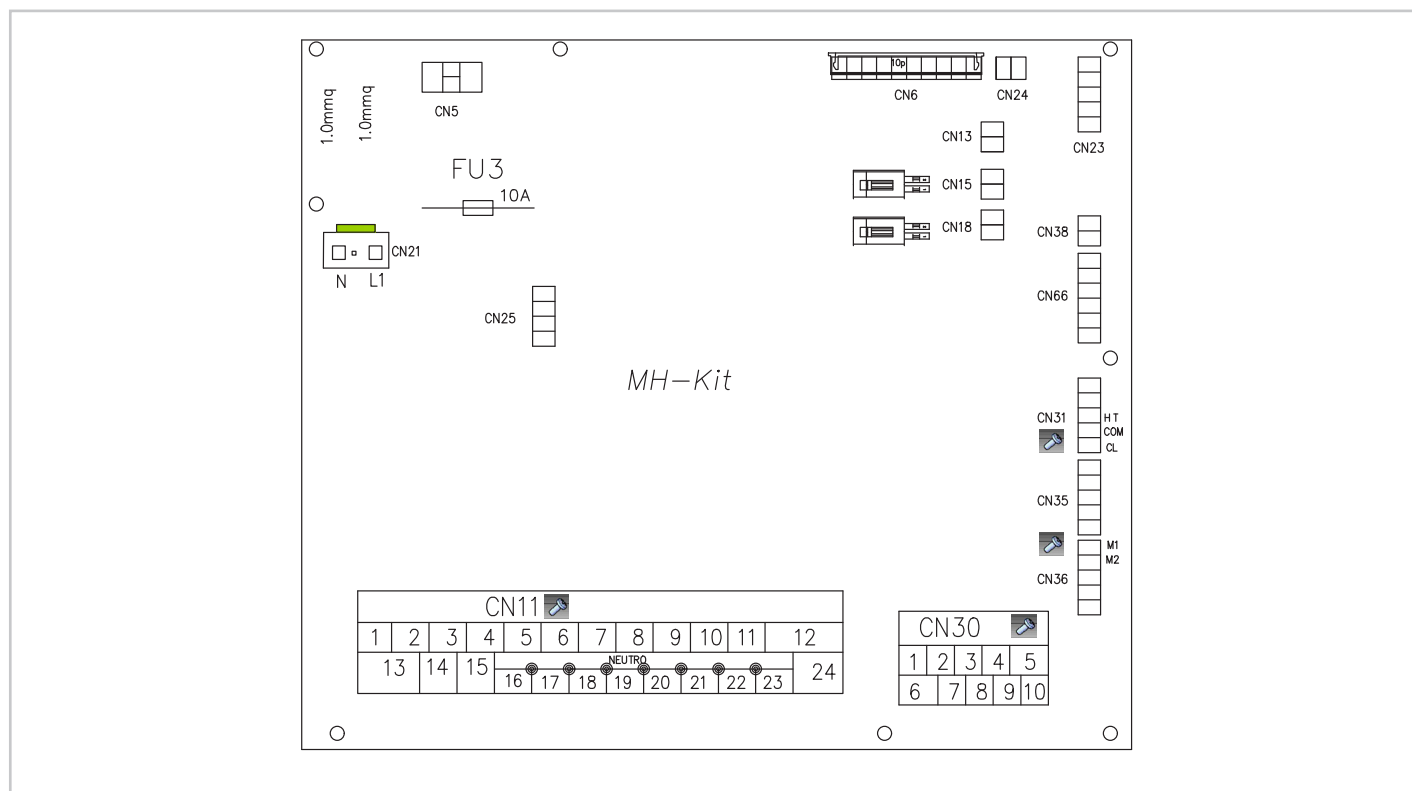

Ref.	Terminal block CN11			220-240 VAC
1	3	SV1 ON	SV1 DHW 3-way valve	Contact en tension
	4	SV1 OFF		
	17	N		
2	7	SV3 ON	SV3 Zone 2 3-way mixing valve	Contact en tension
	5	SV2 ON		
	18	N		
3	9	P_c	pump P_c (zone2)	Contact en tension
	19	N		
4	10	P_o	Pump P_o (zone1)	Contact en tension
	20	N		
5	11	P_s	Solar pump	Contact en tension
	21	N		
6	12	P_d	DHW recirculation pump	Contact en tension
	22	N		
7	13	TBH	TBH heater	Contact en tension
	16	N		
8	14	IBH1	External backup heater	Contact en tension
	16	N		

 See the glossary for the acronyms



## Electrical connections

**i** External electrical components KM..., Fuses, etc. are to be provided by the customer.

**!** Connect as shown in the wiring diagrams.

### 7.4.1 1-zone system

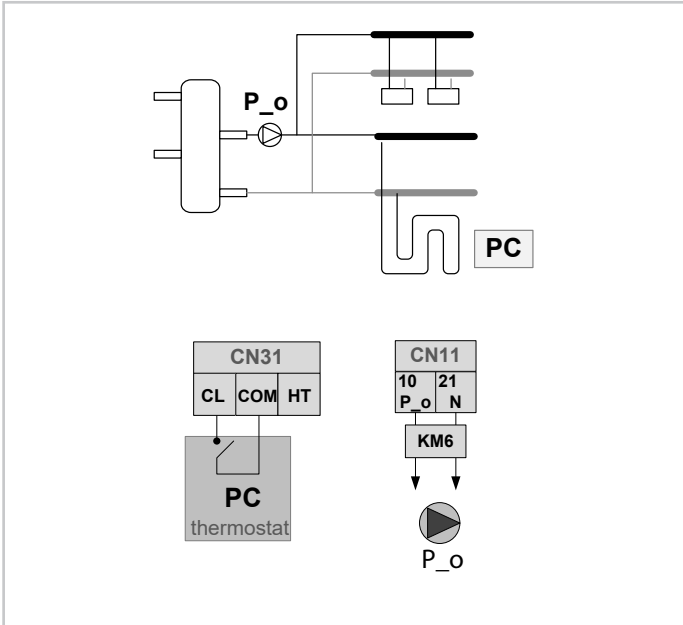

### 7.4.2 Double zone mixed system

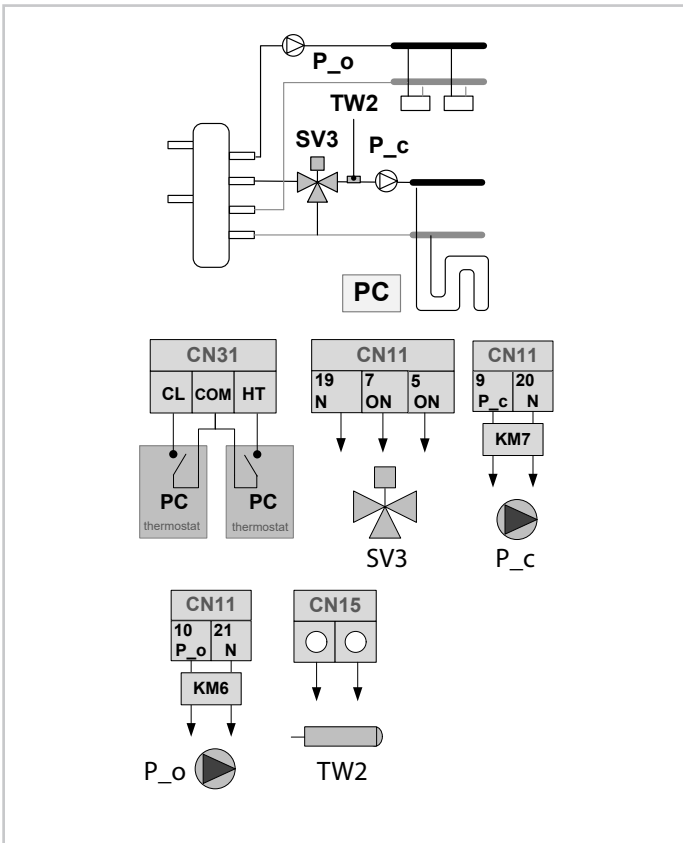

### 7.4.3 DHW recirculation pump

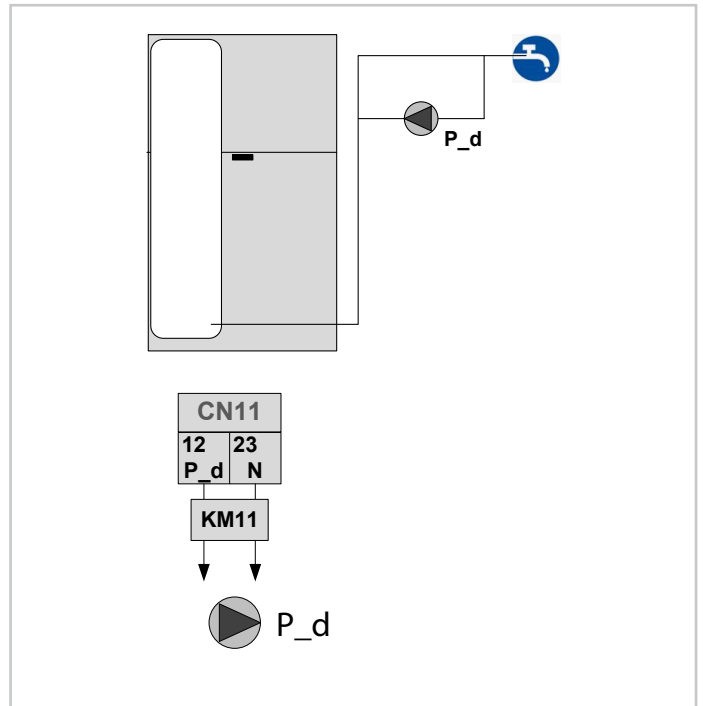

<b>Contact type</b>	<b>220-240 VAC</b>
Maximum tripping of protections (A)	0.2
Cable cross-section (mm <sup>2</sup> )	0.75

### 7.4.4 Solar pump

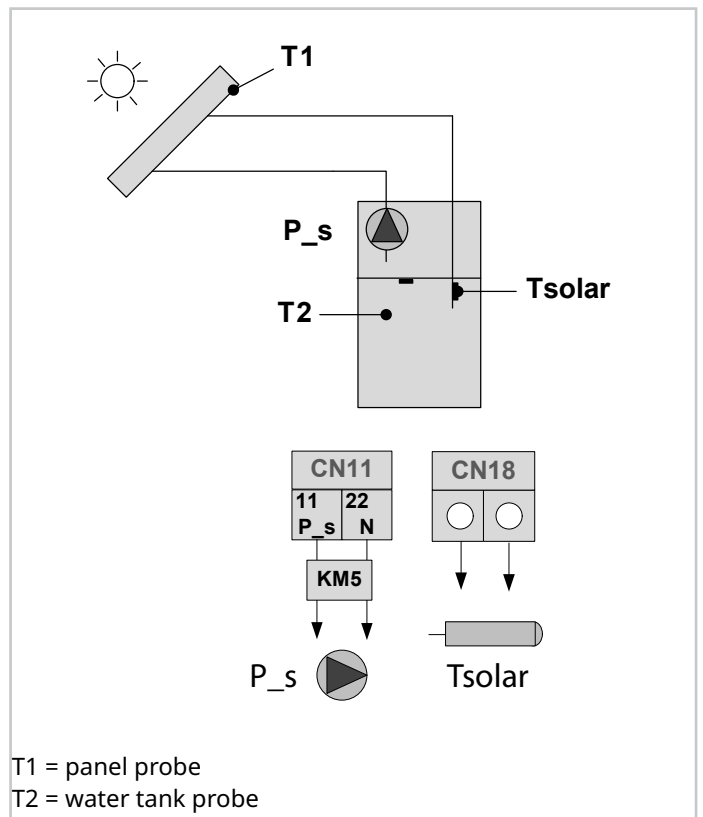

7.4.5 Remote on/off

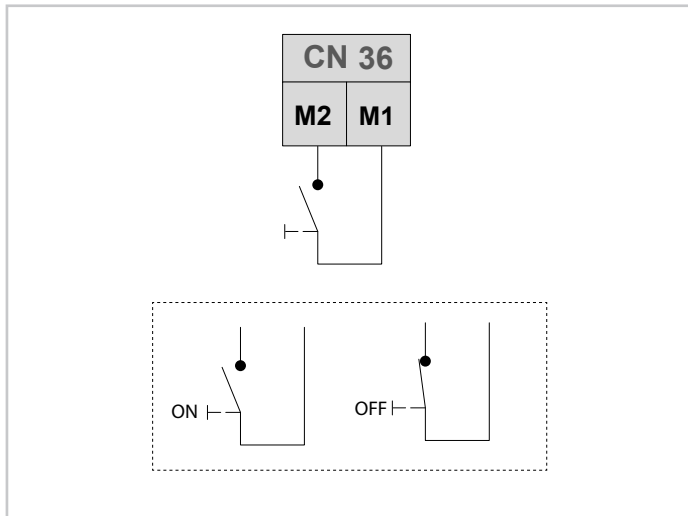

<b>Contact type</b>	<b>220-240 VAC</b>
Maximum tripping of protections (A)	0.2
Cable cross-section (mm <sup>2</sup> )	0.75

7.4.6 Remote environment thermostat

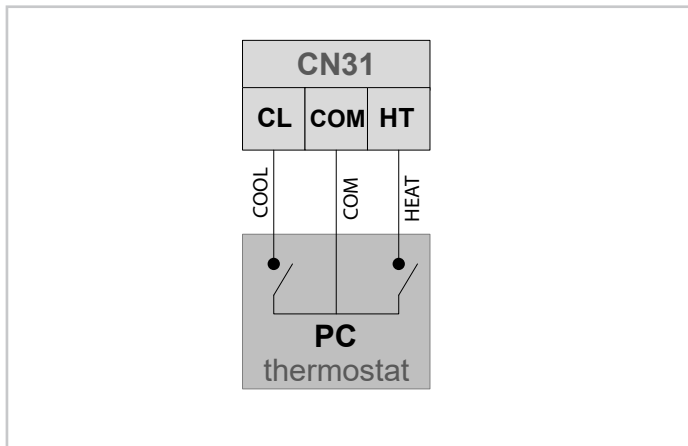

7.4.7 Alarm signal

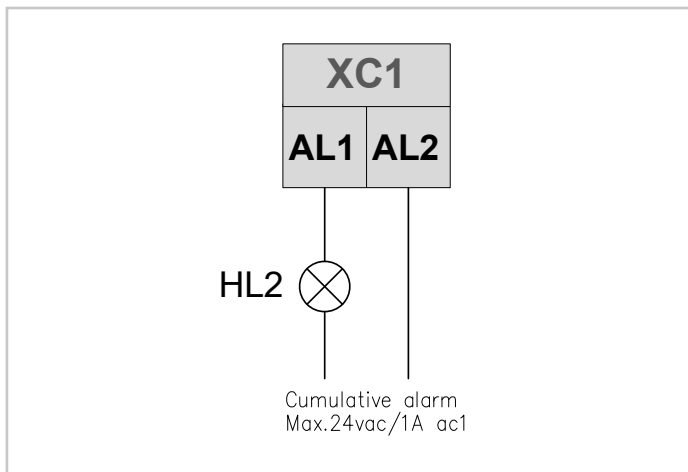

7.4.8 DHW electric heater connection

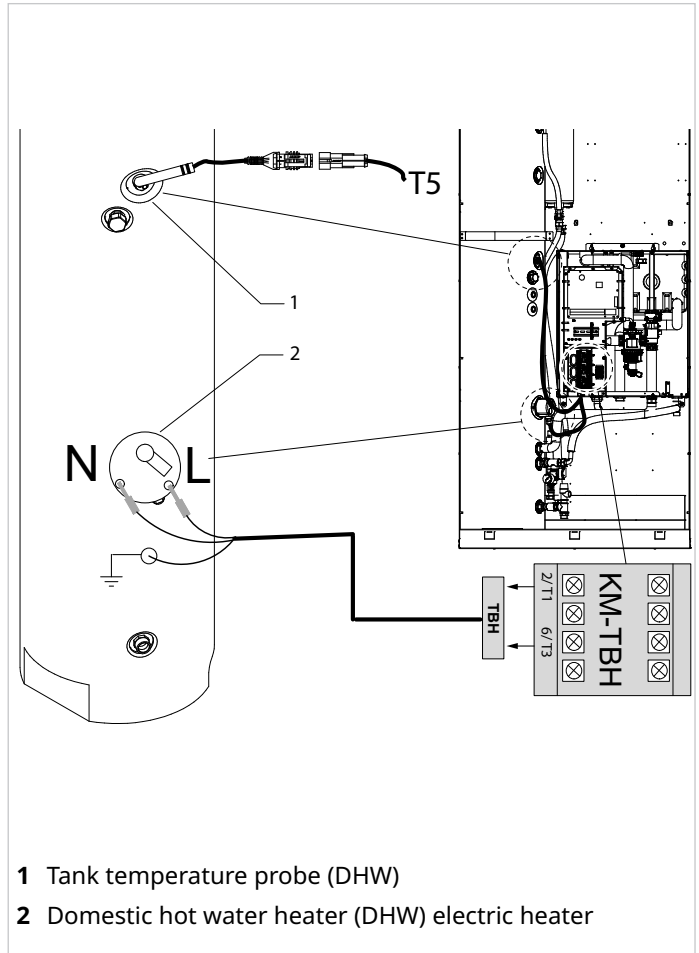

- 1 Tank temperature probe (DHW)
- 2 Domestic hot water heater (DHW) electric heater

**⚠** Before inserting the probe into the well, apply thermal paste.

### 7.5 Keypad + bus connection

Connections to be provided by customer



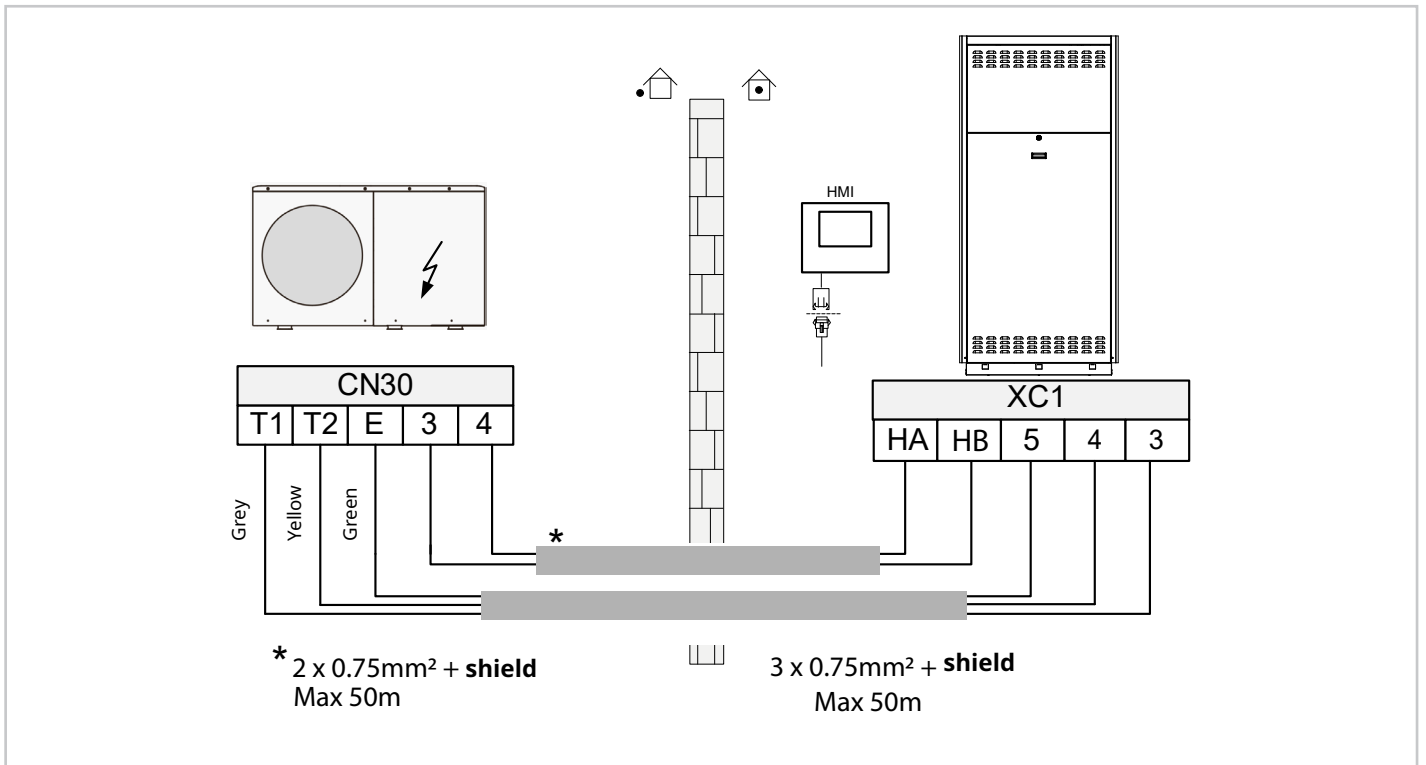

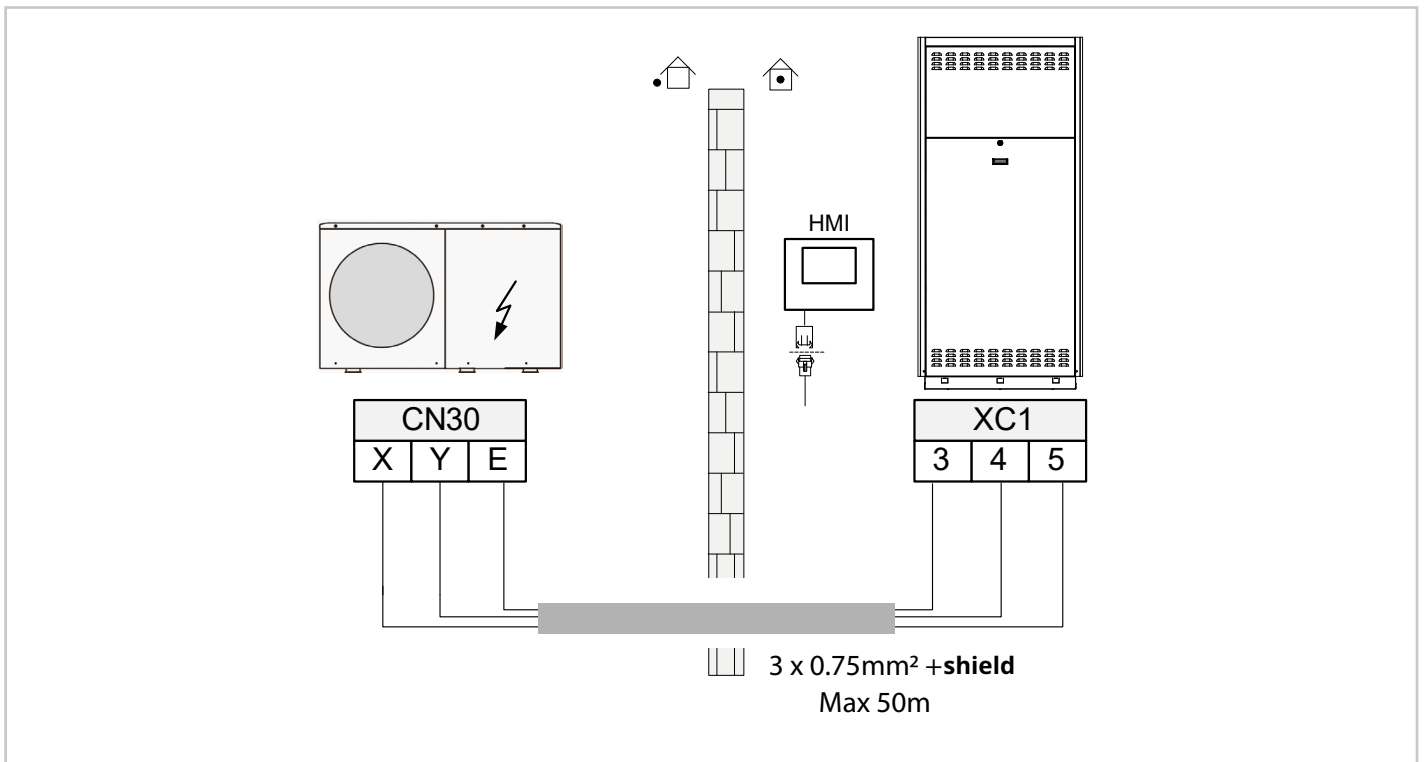

#### R-290 unit



#### R-32 unit



## 8. Starting up the system

-  This section is intended only for the Technical Support Service.
-  The electrical and hydraulic connections and other works typical of the system are the responsibility of the Installer.
-  Operate in compliance with safety regulations in force.
-  Upon request, the service centres performing the start-up.
-  Agree upon in advance the start-up data with the service centre.
-  When installing or servicing, never leave the unit unattended after removing the service panels.
-  **Check that:**
  - the unit should be installed properly and in conformity with this manual
  - the electrical power supply line should be isolated at the beginning
  - the unit isolator is open, locked and equipped with the suitable warning
  - make sure no tension is present

### Remember that:

- during installation, unit settings and parameters should be configured by the Installer according to the installation configuration, climatic conditions, and end-user preferences
  - related settings are accessible and programmable through the user interface
-  Refer to the user interface manual for operation.

### 8.1 Preliminary checks

 For details refer to the different manual sections.

#### 8.1.8.1 Unit power supply: OFF

1	Clearances: <ul style="list-style-type: none"> <li>• check that distances are observed</li> </ul>
2	Water characteristics: <ul style="list-style-type: none"> <li>• check that the allowable water values are respected</li> </ul>
3	Water filter: <ul style="list-style-type: none"> <li>• check that it is correctly installed at the entrance to the aqueduct</li> </ul>
4	Water line input: <ul style="list-style-type: none"> <li>• check the correct connection of the water outlet and water inlet</li> </ul>
5	Non-return valve: <ul style="list-style-type: none"> <li>• check that there is a non return valve on the DHW circulation</li> </ul>
6	DHW expansion vessel: <ul style="list-style-type: none"> <li>• check that the expansion tank is present</li> </ul>
7	System: <ul style="list-style-type: none"> <li>• check that it is charged</li> <li>• check the system pressure</li> <li>• check that it has been vented</li> </ul>
8	On-site wiring: <ul style="list-style-type: none"> <li>• check that all wiring connections comply with the instructions in this manual</li> </ul>
9	Fuses, circuit breakers or protection devices: <ul style="list-style-type: none"> <li>• check that the size and type comply with the instructions in this manual</li> <li>• ensure that no fuses or protective devices have been bypassed</li> </ul>
10	Automatic switch of integrative electric heater: <ul style="list-style-type: none"> <li>• check that the circuit breaker of the additional electric heater in the electrical panel is closed (varies depending on the type of additional electric heater). Refer to the wiring diagram</li> </ul>
11	Automatic switch of supplementary electric heater for DHW cylinder: <ul style="list-style-type: none"> <li>• check the circuit breaker of the supplementary electric resistance for DHW tank is closed (applicable only to units with optional domestic hot water tank)</li> </ul>
12	Internal wiring: <ul style="list-style-type: none"> <li>• check that the wiring and connections inside the electrical cabinet are tight and in good condition</li> <li>• check that the grounding wiring is perfectly tightened and in good condition</li> </ul>
13	Assembly: <ul style="list-style-type: none"> <li>• check that hydraulic connections are properly tightened to avoid water leaks, abnormal noises and vibrations when starting the unit</li> </ul>
14	Damaged components: <ul style="list-style-type: none"> <li>• check the components and circuitry inside the unit for damage or deformation</li> </ul>
15	Power supply voltage: <ul style="list-style-type: none"> <li>• check that the power supply voltage is within the values indicated on the unit's serial number label</li> </ul>

16	Shut-off valve: <ul style="list-style-type: none"><li>• check that all shut-off valves are open</li></ul>
17	Structure: <ul style="list-style-type: none"><li>• check all the structure of the unit is mounted correctly</li></ul>

### 8.1.8.2 Outdoor unit settings

**⚠** The dip-switches on the outdoor unit must be switched as shown in the figure to enable correct communication between the indoor and outdoor units.

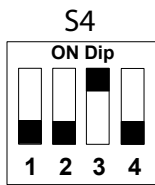

#### R-32

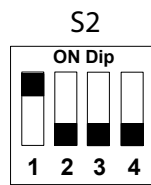

#### R-290



### 8.1.8.3 Unit Power: ON

1	<p>When the unit is turned on, nothing is displayed on the user interface. Check the following anomalies before diagnosing possible error codes:</p> <ul style="list-style-type: none"> <li>• electrical connection problem (power supply or communication signal)</li> <li>• fuse failure on main electronic board</li> </ul>
2	<p>Error code "E8" or "E0" is displayed on the user interface:</p> <ul style="list-style-type: none"> <li>• there is air in the system</li> <li>• water pressure in the system is insufficient</li> <li>• the water flow rate in the system is insufficient</li> </ul> <p> Before starting the operation test, make sure the water system and the water tank are filled with water and the air has been vented. Failure to do so could result in irreversible damage to main system components</p>
3	<p>Error code "EL" is displayed on the user interface:</p> <ul style="list-style-type: none"> <li>• check the wiring between the user interface and the outdoor unit (see wiring diagram)</li> </ul>
4	<p>Initial start-up at low outside temperature:</p> <ul style="list-style-type: none"> <li>• for the initial start-up when the outside temperature is low, the water should be heated gradually</li> <li>• use the underfloor preheating function</li> </ul> <p> Refer to the user interface manual for operation.</p> <p>For radiant panel systems</p> <p> If the temperature rises abruptly in a short time, the floor could suffer irreversible damage.</p>

## 8.2 SYSTEM CONFIGURATION

 For system configuration, of advanced features, refer to the user interface manual.

## 9. Maintenance

### 9.1 Prerequisites

 This section is intended only for the Technical Support Service.

 All operations must be carried out by personnel who meet the requirements of current regulations and are trained in the risks related to such operations.

 Operate in compliance with safety regulations in force.

#### The maintenance allows to:

- maintaining the unit efficient
- reduce the deterioration speed all the equipment is subject to over time
- collect information and data to understand the efficiency state of the unit and prevent possible faults

#### Check that:

- the electrical power supply line should be isolated at the beginning
- the unit isolator is open, locked and equipped with the suitable warning
- make sure no tension is present

 After turning off the power, wait at least 5 minutes before accessing to the electrical panel or any other electrical component.

 Before accessing check with a multimeter that there are no residual stresses.

 When installing or servicing, never leave the unit unattended after removing the service panels.



## 9.2 Maintenance check list

Intervention frequency (months)		1	6	12
1	presence of corrosions			X
2	panel fixing			X
3	water filter cleaning		X	
4	dirt separator cleaning			X
5	expansion tank			X
6	hydraulic system filling pressure		X	
7	water: quality, pH, glycol concentration		X	
8	air in the piping			X
9	drain dirt separator	X	X	X
10	anode check		X	
11	check solar panel fittings for leaks		X	
12	check of the fixing and the insulation of the power lead			X
13	check of the earthing cable			X
14	electric panel cleaning			X
15	power remote controls status			X
16	clamp closure, cable isolation integrity			X
17	voltage and phase unbalancing (no load and on-load)			X
18	absorptions of the single electrical loads		X	
19	electronic anode		X	
20	leak control *		X	
21	control device test: alarm signal, thermometers, probes, pressure gauges, etc.		X	
22	check schedulers, setpoints, compensations, etc.		X	
23	fill in the unit's booklet			

 \*Refer to the local regulations. Companies and technicians that carry out installation, maintenance/fixing, leak control and recovery interventions must be CERTIFIED as required by local regulations.

### 9.3 Unit booklet

It's advisable to create a unit booklet to take notes of the unit interventions.

In this way it will be easier to adequately note the various interventions and aid any troubleshooting.

#### Report on the booklet:

- date
- intervention description
- carried out measures etc.

### 9.4 Standby mode

#### In case of a long period of inactivity:

- ▶ turn off the power
- ▶ avoid the risk of frost (use glycol or empty the system)

### 9.5 Emptying the system

The units are not fitted with a drain valve, so one must be provided on a pipe connecting to the system near to the device and below it.

 All operations must be carried out with the unit shut down and disconnected from the mains power supply.

#### Before emptying:

- ▶ check that the system water filling/refilling valve is closed

#### To drain the system:

- ▶ open the drain valve on the outside of the device
- ▶ open all of the system and terminal relief valves

### 9.6 Structure

 Check the condition of the parts making up the structure.

 Paint so as to eliminate or reduce oxidation at the points in the unit where this problem may occur

 Check the fastening of the external paneling of the unit. Poor fastening may give rise to malfunctions and abnormal noise and vibration,

### 9.7 Water pressure

- ▶ check that the water pressure is greater than 1 bar

#### If necessary:

- ▶ add water up to 1.5-1.8 bar

### 9.8 Water filter

- ▶ check and clean the water filter

#### In case of obstruction:

- ▶ clean the filter

### 9.9 Expansion vessel

- ▶ check the expansion vessel charge
- ▶ check at least once a year

If you necessary load with nitrogen, take care that the pressure does not exceed the value indicated on the label.

### 9.10 Unit electrical panel

- ▶ visually inspect the electrical panel
- ▶ check the tightness of the connections
- ▶ check the cleanliness of the electrical panel

### 9.11 Using glycol

#### least once a year

- ▶ check the glycol concentration and pH value of the system

#### A pH value below 8.0:

- ▶ indicates that a significant proportion of the inhibitor has been consumed
- ▶ topping up

#### A pH value of less than 7.0:

- ▶ indicates that the glycol has oxidised
- ▶ drain and flush the system thoroughly to prevent serious damage

 The glycol solution must be disposed of in accordance with the local laws and regulations in force.

## 9.12 Magnetic sludge

Magnetic filter separates the impurities (sand particles, rust ... etc) present in the system water. The impurities are collected in a settling chamber. Cleaning the filter can also be done with a working system.

### Clean the filter:

- during the start up of the unit
- after one week from the start up
- after one month from start up
- once a year

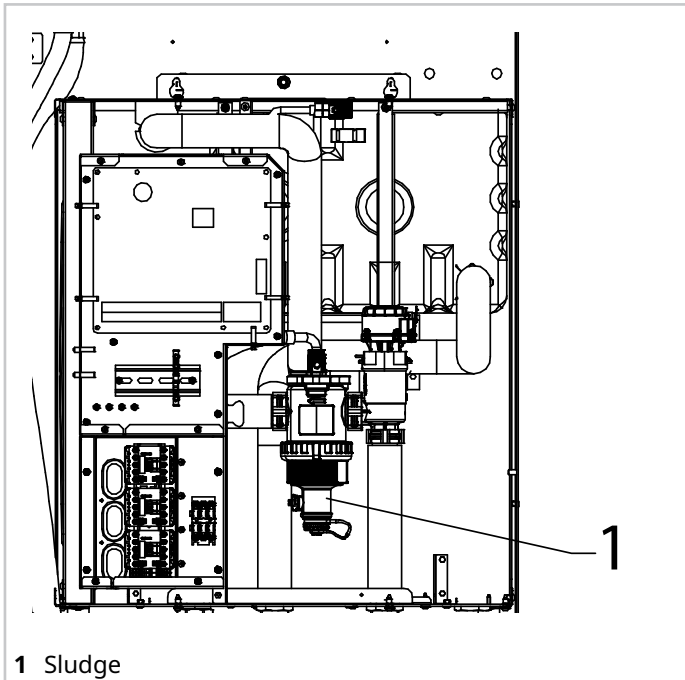

### Clean the filter:

- ▶ remove the magnetic ring
- ▶ open the tap to purge impurities
- ▶ close the tap

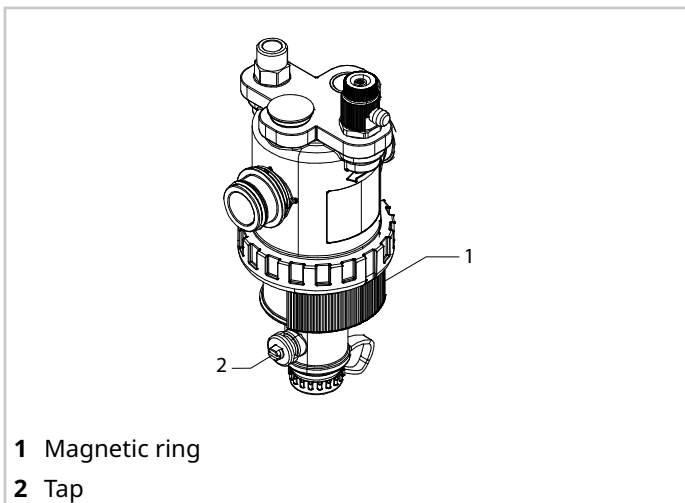

### Cleaning (extraordinary)

Close the shut-off valves of the system and water supply.

### Disassembly sequence:

- ▶ unscrew the ring nut of the lower cover of the dirt separator
- ▶ remove the filter
- ▶ clean the filter
- ▶ clean the filter and the bottom cover
- ▶ close the bottom cover of the dirt separator
- ▶ open the shut-off valves of the plant and aqueduct

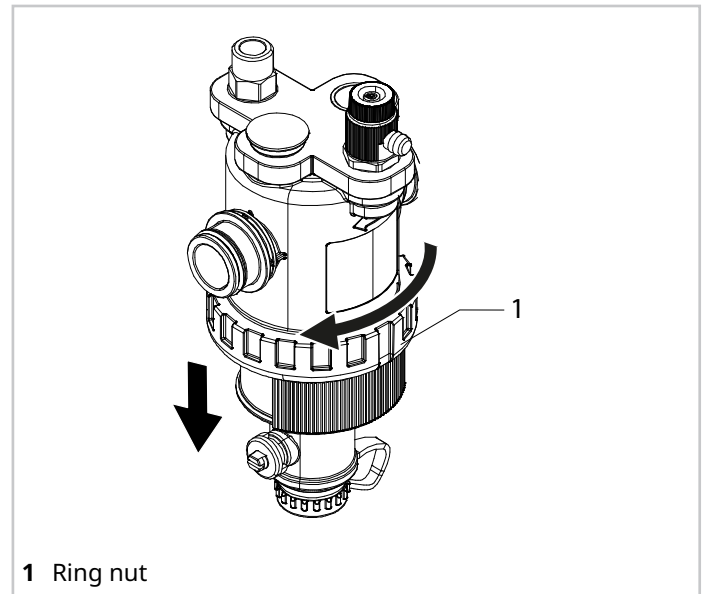

⚠ Check pressure of the plant.

## 9.13 Safety valve

Almost all losses are caused by impurities deposited inside the valve.

- ▶ check the safety valve for leakage
- ▶ check that the pressure relief valve pipe is correctly positioned for draining the water
- ▶ check that the safety valve pipe is free from obstruction

### To carry out a wash:

- ▶ manually open the valve
- ▶ rotate the knob in the sense indicated by the arrow in the knob

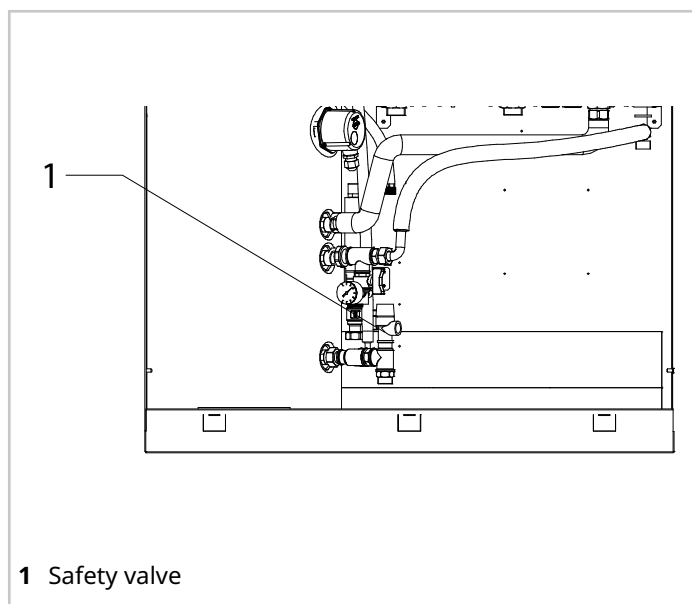

- ⚠ Pay attention to possible scalding from the hot water coming out of the valve.
- ⚠ It's normal if some water drops from the hole of safety valve during operation.
- ⚠ But, if there is a great amount of water, call your service agent for instructions.

## 9.14 Sacrificial anode

Magnesium sacrificial anodes protect the water tank from corrosion.

### Anode check:

- ▶ disconnect the power supply
- ▶ close the water inlet tap on the system (refer to the General system diagram)
- ▶ open the hot water tap to drop the pressure inside the water tank
- ▶ connect a pipe to the drain tap
- ▶ direct it towards a suitable drain or collection tank
- ▶ open the drain tap
- ▶ empty the water tank to point (A)
- ▶ unscrew the cap
- ▶ pull out the anode

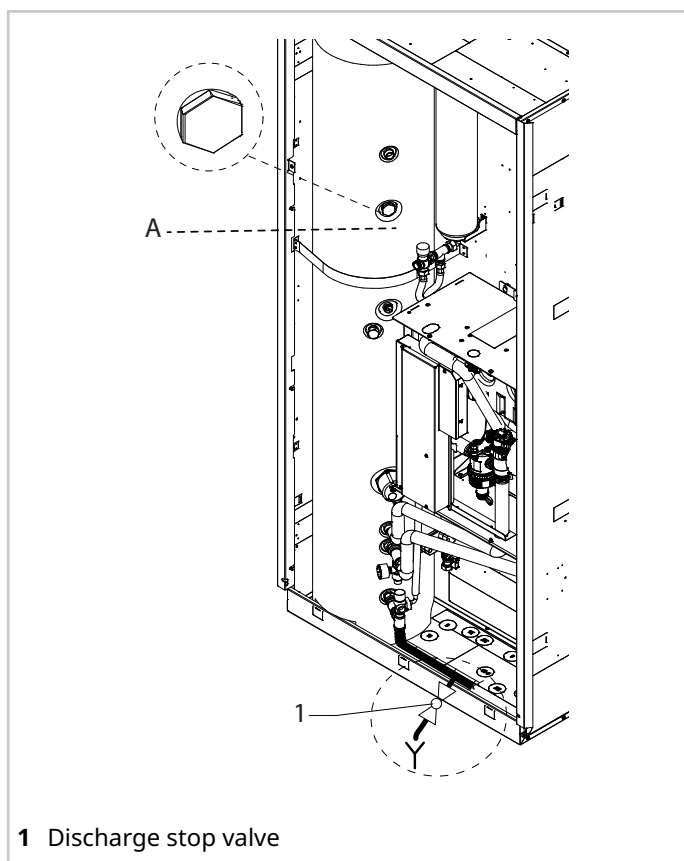

### The anode must be:

- checked every 6 to 12 months
- replaced every 2 to 3 years

**i** Check its wear, replace if  $\varnothing < 10 - 15$  mm.

**⚠** Possible burns, the outlet water temperature can be very hot.

# 10. Decommissioning

## 10.1 Disconnection

 Awaiting decommissioning and disposal, the unit can also be stored outdoors, as bad weather and rapid changes in temperature do not harm the environment provided that the electric, cooling and hydraulic circuits of the unit are intact and closed.



### 10.1.1 WEEE INFORMATION

The manufacturer is registered on the EEE National Register, in compliance with implementation of Directive 2012/19/ EU and relevant national regulations on waste electrical and electronic equipment.

This Directive requires electrical and electronic equipment to be disposed of properly.

Equipment bearing the crossed-out wheeled bin mark must be disposed of separately at the end of its life cycle to prevent damage to human health and to the environment.

Electrical and electronic equipment must be disposed of together with all of its parts.

To dispose of "household" electrical and electronic equipment, the manufacturer recommends you contact an authorised dealer or an authorised ecological area.

"Professional" electrical and electronic equipment must be disposed of by authorised personnel through established waste disposal authorities around the country.

In this regard, here is the definition of household WEEE and professional WEEE:

WEEE from private households: WEEE originating from private households and WEEE which comes from commercial, industrial, institutional and other sources which, because of its nature and quantity, is similar to that from private households. Subject to the nature and quantity, where the waste from EEE was likely to have been by both a private household and users of other than private households, it will be classed as private household WEEE;

Professional WEEE: all WEEE which comes from users other than private households.

This equipment may contain:

- refrigerant gas, the entire contents of which must be recovered in suitable containers by specialised personnel with the necessary qualifications;
- lubrication oil contained in compressors and in the cooling circuit to be collected;
- mixtures with antifreeze in the water circuit, the contents of which are to be collected;
- mechanical and electrical parts to be separated and disposed of as authorised.

When machine components to be replaced for maintenance purposes are removed or when the entire unit reaches the end of its life and needs to be removed from the installation, waste should be separated by its nature and disposed of by authorised personnel at existing collection centres.

## 10.2 Residual risks

Refer to the outdoor unit manual.

## 11. Technical data

### Construction characteristics - Indoor unit

SIZE			A
<b>System characteristics</b>			
Maximum system pressure		bar	3,0
System expansion tank	1	l	8,0
Expansion tank pre-charge		bar	1,0
System water connections		inch	1"
<b>DHW Characteristics</b>			
Type of Tank		-	Acciaio INOX AISI 316 L
Domestic hot water Tank Volume		l	150
Internal coil exchange surface		m <sup>2</sup>	1,0
Water tank leakage		W/K (kWh/24h)	1.69 (1.82)
DHW safety electric heater		kW	2,0
Maximum DHW circuit pressure		bar	6,0
DHW expansion tank		l	8,0
DHW water connections		inch	3/4"
<b>Dimensions</b>			
Operation (L x W x H)		mm	950 x 360 x 2200
Packaging (L x W x H)		mm	2300 x 430 x 1225
Operation weight		kg	317
Shipping weight		kg	180

1. Sufficient volume up to a maximum of 70 litres of system water content.

### Hydraulic data - Indoor unit + Outdoor unit - R32

SIZE		2.1	3.1	4.1	5.1
Minimum system water content	l	30	30	70	70
Minimum water flow rate allowed	l/s	0,11	0,11	0,11	0,11
Maximum water flow rate allowed	l/s	0,25	0,35	0,46	0,58
Net boiler capacity	l	143	143	143	143
DHW tank setpoint	°C	50	50	50	50
Water mixed at 40°C (V40)	l	188	188	188	188
Heating time	h:min	02:11	02:11	01:47	01:47
Energy consumption during heating	kWh	1,90	1,90	2,00	2,00

1. The minimum water content of the area with the smallest water volume is considered.

### Hydraulic data - Indoor unit + Outdoor unit - R290

SIZE		2.1	3.1	4.1	5.1
Minimum system water content	l	30	30	70	70
Minimum water flow rate allowed	l/s	0,10	0,10	0,17	0,17
Maximum water flow rate allowed	l/s	0,42	0,42	0,64	0,69
Net boiler capacity	l	143	143	143	143
DHW tank setpoint	°C	50	50	50	50
Water mixed at 40°C (V40)	l	188	188	188	188
Heating time	h:min	01:44	01:44	01:18	01:18
Energy consumption during heating	kWh	2,10	2,10	2,25	2,25

1. The minimum water content of the area with the smallest water volume is considered.

## EASYIn - Standard unit

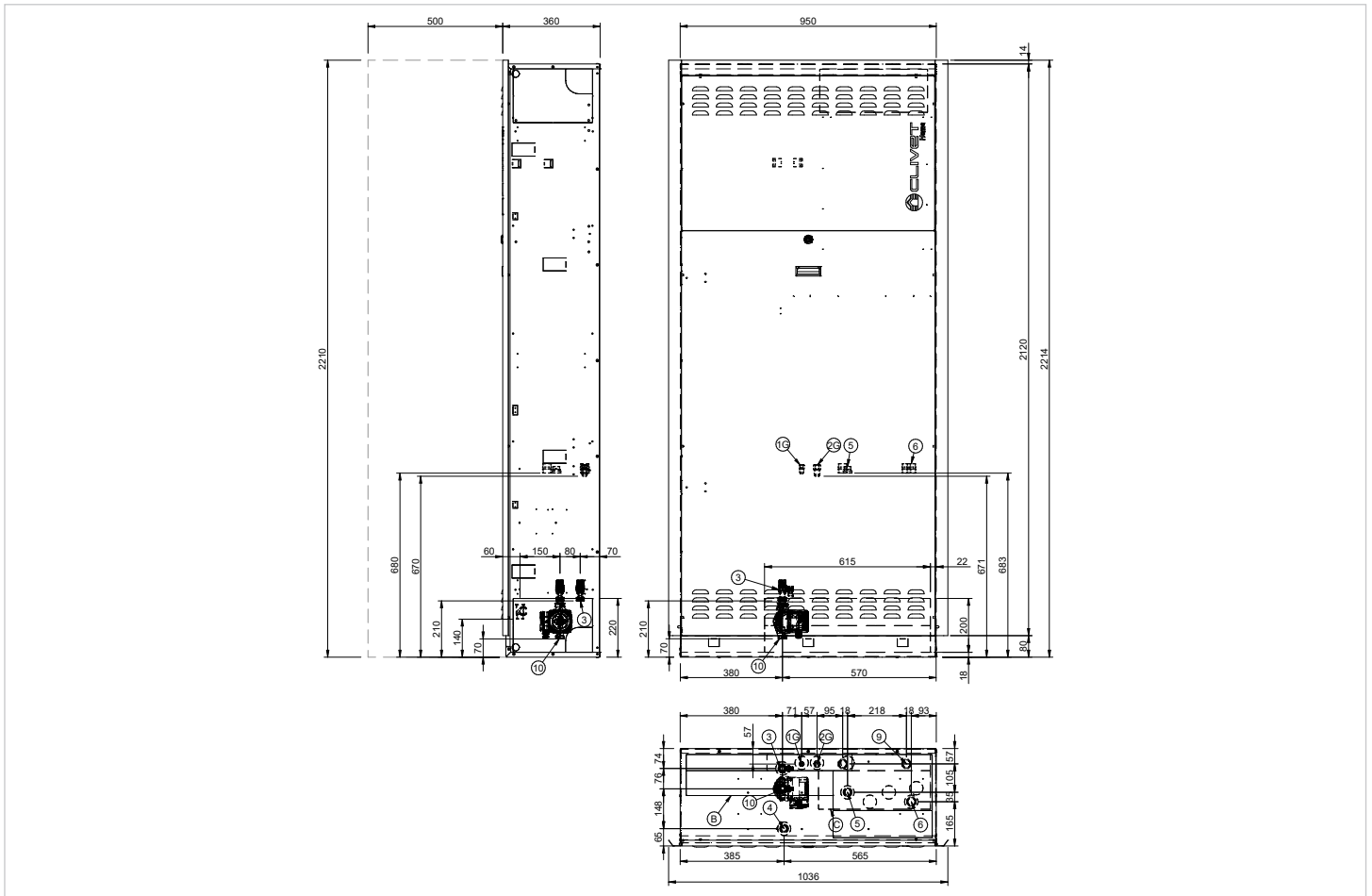

- 1. (G) Refrigerant line connection (Liquid) 3/8" SAE
  - 2. (G) Refrigerant line connection (Gas) 5/8" SAE
  - 3. Hot water supply M G3/4"
  - 4. Water supply system inlet M G3/4"
  - 5. Supply to system M G 1"
  - 6. Return from system M G 1"
  - 7. Condensation drain and valves
  - 8. DHW circulation M G3/4" G (Option)
  - A. Flaps for anchoring on masonry
  - B. Pre-cut area for piping passage
  - C. Pre-cut area for coaxial smoke exhaust 100/60 mm. (For Hybrid version only)
- \* Functional spaces

SIZE		STD indoor unit	STD additional practical cabinet for system accessories	150 L water tank + STD unit components kit
Operation weight	kg	50	70	205
Shipping weight	kg	47	65	55

The presence of optional accessories may result in significant variation of the weights indicated.

FOR OVER 30 YEARS, WE HAVE BEEN OFFERING  
SOLUTIONS TO ENSURE SUSTAINABLE  
COMFORT AND THE WELL-BEING OF PEOPLE  
AND THE ENVIRONMENT



Info & Contacts: [www.clivet.com](http://www.clivet.com)



**MideaGroup**  
*humanizing technology*