

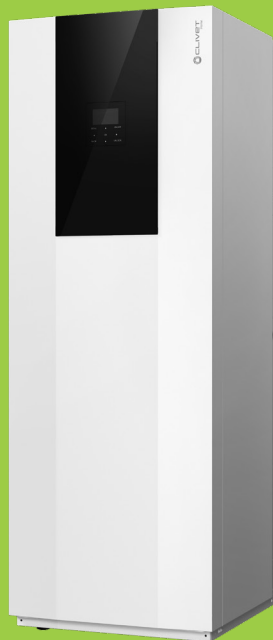

EASYTank

HQCN-NEE 1 TC

Manual
for installation,
and maintenance



en

M0TL00002-01 10-2024

Keep this manual together with the wiring diagram in an accessible place for the operator for future reference.

Dear Customer,

We congratulate you on choosing these product.

Clivet has been working for years to offer systems able to assure the maximum comfort for a long time with highly-reliable, efficient, high-quality and safe solutions.

The target of the company is to offer advanced systems, that assure the best comfort and reduce energy consumption as well as the installation and maintenance costs for the entire life-cycle of the system.

With this manual, we want to give you information that are useful for all phases: from reception, installation and use to disposal - so that such an advanced system can provide the best performances during installation and use.

Best regards and have a good read.

CLIVET Spa

The original instructions are written in Italian.

All other languages are translations of the original instructions.

The data contained in this manual is not binding and may be changed by the manufacturer without prior notice. Reproduction, even partial, is FORBIDDEN.

© Copyright - CLIVET S.p.A. - Feltre (BL) - Italia.

Summary

| | | |
|-----------|--|-----------|
| 1. | Glossary | 5 |
| 2. | General | 6 |
| 2.1 | About the manual..... | 6 |
| 2.2 | General safety warnings..... | 7 |
| 3. | Presentation of the product | 8 |
| 3.1 | Identification..... | 8 |
| 3.2 | Regulatory framework..... | 8 |
| 3.3 | Intended use..... | 8 |
| 3.4 | Description..... | 8 |
| 3.5 | Main components..... | 9 |
| 3.6 | Components supplied with the unit..... | 10 |
| 3.7 | Compatible accessories..... | 10 |
| 4. | Before installation | 11 |
| 4.1 | Prerequisites..... | 11 |
| 4.2 | Reception..... | 11 |
| 4.3 | Storage..... | 11 |
| 4.4 | Handling..... | 12 |
| 4.5 | Removal of the packaging..... | 12 |
| 5. | Installation | 14 |
| 5.1 | Prerequisites..... | 14 |
| 5.2 | General diagram..... | 14 |
| 5.3 | Clearances..... | 15 |
| 5.4 | Access to internal parts..... | 15 |
| 6. | Water connections | 17 |
| 6.1 | General system diagram Standard..... | 17 |
| 6.2 | General system diagram..... | 18 |
| 6.3 | Position of connections..... | 19 |
| 6.4 | Hydraulic connection..... | 19 |
| 6.5 | Water filter..... | 20 |
| 6.6 | DHW safety valve..... | 20 |
| 6.7 | DHW tank filling..... | 21 |
| 6.8 | Loading the plant..... | 21 |
| 7. | Electrical connections | 23 |
| 7.1 | Prerequisites..... | 23 |
| 7.2 | Cable inlet..... | 24 |
| 7.3 | Connecting the power supply..... | 25 |
| 7.4 | External component connections..... | 27 |
| 7.5 | Keypad + bus connection..... | 28 |
| 8. | Starting up the system | 31 |
| 9. | Maintenance | 35 |
| 9.1 | Prerequisites..... | 35 |
| 9.3 | Unit booklet..... | 37 |

| | | |
|------------|---------------------------------|-----------|
| 9.4 | Standby mode | 37 |
| 9.5 | Emptying the system..... | 37 |
| 9.6 | Cleaning the outer coating..... | 37 |
| 9.7 | Water pressure..... | 37 |
| 9.8 | Water filter..... | 37 |
| 9.9 | Expansion vessel..... | 37 |
| 9.10 | Unit electrical panel..... | 37 |
| 9.11 | Using glycol | 37 |
| 9.12 | Magnetic sludge | 38 |
| 9.13 | Safety valve..... | 39 |
| 9.14 | Electronic anode | 40 |
| 10. | Decommissioning | 41 |
| 10.1 | Disconnection | 41 |
| 10.2 | Residual risks | 41 |
| 11. | Technical data | 42 |

1. Glossary

Acronyms or abbreviations are used in this manual to indicate components or parameters. The acronyms and their meanings are given in the table.

| Sign | Description |
|----------------|--|
| DHW | Domestic hot water |
| AHS | Backup boiler |
| HMI | User interface |
| IBH | Backup electric heater |
| OFN | Oxygen-Free-Nitrogen |
| P _i | Outdoor packaged unit pump |
| P _o | Secondary circuit pump (or Zone 1 pump for double zone systems) |
| P _c | Zone 2 pump (for double zone systems) |
| P _d | DHW recirculation pump |
| P _s | Solar thermal circuit pump |
| P _x | Defrosting status or alarm status |
| Pe | Evaporating pressure |
| Pc | Condensing pressure |
| SV1 | 3-way circuit/DHW diverter valve |
| SV2 | 3-way diverter valve for direct double zone systems |
| SV3 | 3-way mixing valve for mixed circuit |
| TBH | Backup electric heater for DHW tank |
| T1 | Water supply temperature from additional heating source (with IBH heater or AHS boiler) |
| T2 | Refrigerant temperature entering the user side exchanger (plate heat exchanger) in Cooling mode (or leaving in Heating mode) |
| T3 | Refrigerant temperature leaving the source exchanger (coil) in Cooling mode (or entering in Heating mode) |
| T4 | Outdoor air temperature |
| T5 | DHW tank temperature |
| T1S | Water supply temperature setpoint |
| Ta | Room air temperature, detected by the probe in the HMI |
| Tbt1 | Inertial storage tank temperature |
| Th | Compressor suction refrigerant temperature |
| Tp | Compressor discharge refrigerant temperature |
| Tsolar | Water temperature in the solar thermal circuit |
| Tw2 | Water supply temperature for the mixed zone (for double zone systems) |
| TWin | Unit water return temperature |
| TWout | Unit water supply temperature |

2. General

2.1 About the manual

- The manual ensures proper installation, use and maintenance of the unit
- this manual is an integral and essential part of the product
- keep this manual together with the wiring diagram in an accessible place for the operator. It should always accompany the product, even if it is transferred to another owner or user
- recipients of the instructions in the manual are indicated in the "Recipients" chapter
- the recipient is indicated at the beginning of each section of the manual
- recipients, to the extent of their responsibility, are required to read the instructions and warnings in this manual as they provide important information on safe installation, use and maintenance.

Remember that:

- the manufacturer The manufacturer accepts no liability for damage to persons or property resulting from failure to observe the rules in this manual
- failure to observe the instructions in this manual will result in forfeiture of the warranty
- the manufacturer reserves the right to make changes or improvements to this documentary material and to the units without prior notice
- visit the manufacturer's website for up-to-date details
- this manual contains proprietary information, all rights reserved, it may not be reproduced or photocopied, either in whole or in part, without the prior written consent of manufacturer.

2.1.1 Symbols

The symbols in the following chapter can be found in the manual and on the product, and provide quick and clear information for correct and safe use.

2.1.1.1 Safety symbols

Danger

This symbol indicates warnings, failure to comply may result in serious harm to health and fatal injuries.

Warning

This symbol indicates warnings, failure to comply may result in irreparable damage to the product or harm to the environment.

Prohibition

This symbol indicates operations that must never be

carried out.

Note

This symbol indicates important information.

2.1.1.2 Editorial symbols

In the texts

Purpose of the action: indicates the purpose of a sequence of actions.

(it is identified by bold text followed by :)

- ▶ this symbol indicates actions that are required
- this symbol indicates the expected result after an action
- this symbol indicates the lists

In the images

1 uniquely indicates a component

 indicates a group of components

 indicates a sequence of actions

In the images, dimensions are expressed in millimetres unless otherwise indicated.

2.1.1.3 Symbols on the unit

The following symbols are used in some parts of the product:



Instructions for the User

Read the User Manual carefully before using the product.



Instructions for the User

Read the Installer Manual carefully before installing the product.



Instructions for the Technical Support Service

Read the Technical Support Service Manual carefully before carrying out any operation on the product.

2.1.2 Recipients

2.1.2.1 User

Inexperienced person who is capable of:

- operating the product safely for people, for the product and for the environment
- interpreting elementary diagnostics of faults and abnormal operating conditions
- carrying out simple adjustment, test and maintenance operations.

2.1.2.2 Installer

Experienced and qualified person able to:

- to put the product in a safe operating condition for people, for the product and for the environment
- to comply with the regulations in force in the country of destination
- to provide the user with basic information on safe use and maintenance in accordance with this manual and current national regulations
- comply with the regulations in force in the country of destination.

2.1.2.3 Technical support service

Experienced person, qualified and authorised directly by the manufacturer to:

- carry out a diagnosis of product faults and abnormal operation, possibly using information provided by the user
- rectify faults, carrying out the necessary repairs, replacements and adjustments that will restore the product's ability to function correctly and safely for the people, for the product and for the environment
- comply with the regulations in force in the country of destination.

2.1.3 Document organisation

- The manual is divided into sections, each dedicated to one or more recipients
- the recipient is indicated at the beginning of each section of the manual.

2.2 General safety warnings

 Read the "About the manual" chapter carefully before proceeding with any operation.

 Each chapter contains specific warnings for the operations given therein. These warnings should be read before starting any activities.

 For every operation, always comply with current national regulations.

 All personnel must be aware of the operations and of the hazardous situations that may arise when starting any operations on the unit.

 Any contractual and non-contractual liability for damage caused to persons, animals or property by installation, adjustment or maintenance errors or improper use is excluded.

 Any uses not expressly indicated in this manual are not permitted.

 Do not change or tamper with the device as this can lead to hazardous situations.

 Use appropriate safety clothing and equipment.

 The manufacturer accepts no liability for failure to comply with current safety and accident prevention regulations.

 The manufacturer reserves the right to make changes to its models at any time to improve its product, subject to the essential characteristics described in this manual.

 The manufacturer is not obliged to add these changes to units previously manufactured, already delivered or being built.

 The unit is suitable for use by children aged 8 years and over and by persons with reduced physical, sensory or mental capabilities or lack of experience or knowledge if they are properly supervised or have received instructions on the safe use of the device and have understood the associated hazardous situations. Children must not play with the device. Cleaning and maintenance operations must not be carried out by children without supervision.

 It is forbidden to touch the device with wet or damp parts of the body.

 It is forbidden to carry out any operation before disconnecting the device from the mains power supply by turning the system's main switch to "off".

 It is forbidden to change the safety or control devices without the device manufacturer's authorisation and instructions.

 It is forbidden to pull, unplug or twist the electrical cables coming out of the device, even if it is disconnected from the mains power supply.

 It is forbidden to introduce objects and substances through the air intake and supply grilles.

 It is forbidden to open the access doors to internal parts of the unit without first turning the system's main switch to "off".

3. Presentation of the product

3.1 Identification

The serial number label is positioned on the unit and allows to identify all the unit features.

The matriculation plate shows the indications foreseen by the standards, in particular:

- unit type
- serial number
- year of manufacture
- wiring diagram number
- electrical data
- manufacturer logo and address

i The serial number uniquely identifies each unit and enables specific parts to be identified.

! Tampering, removal, missing identification labels or anything else that does not allow the product to be safely identified, makes installation and maintenance operations difficult.

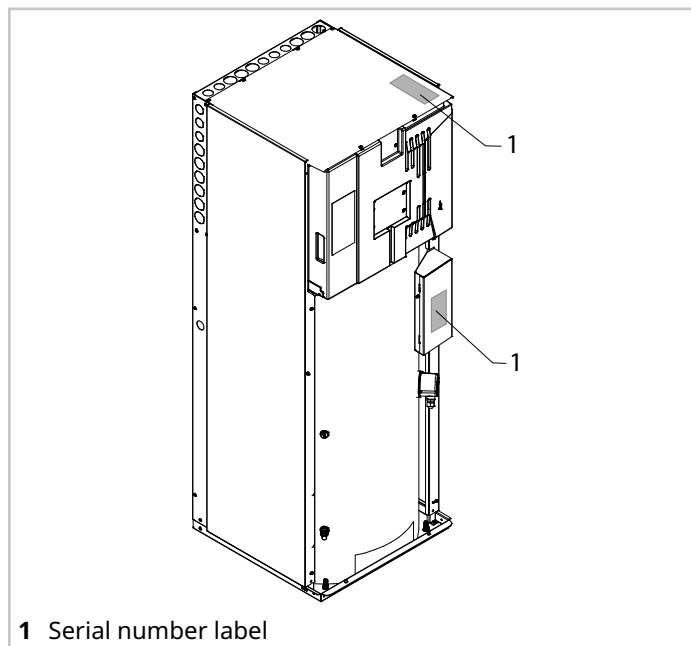

3.2 Regulatory framework

The relevant regulatory framework can be found in the declaration of conformity enclosed with this document.

3.3 Intended use

The units are designed for:

- combination with Edge EVO 2.0 - EXC and Edge F units
- indoor installation
- operation within the limits and with their performance characteristics set out in this document.

3.4 Description

Hydraulic module for combination with packaged heat pumps.

3.5 Main components

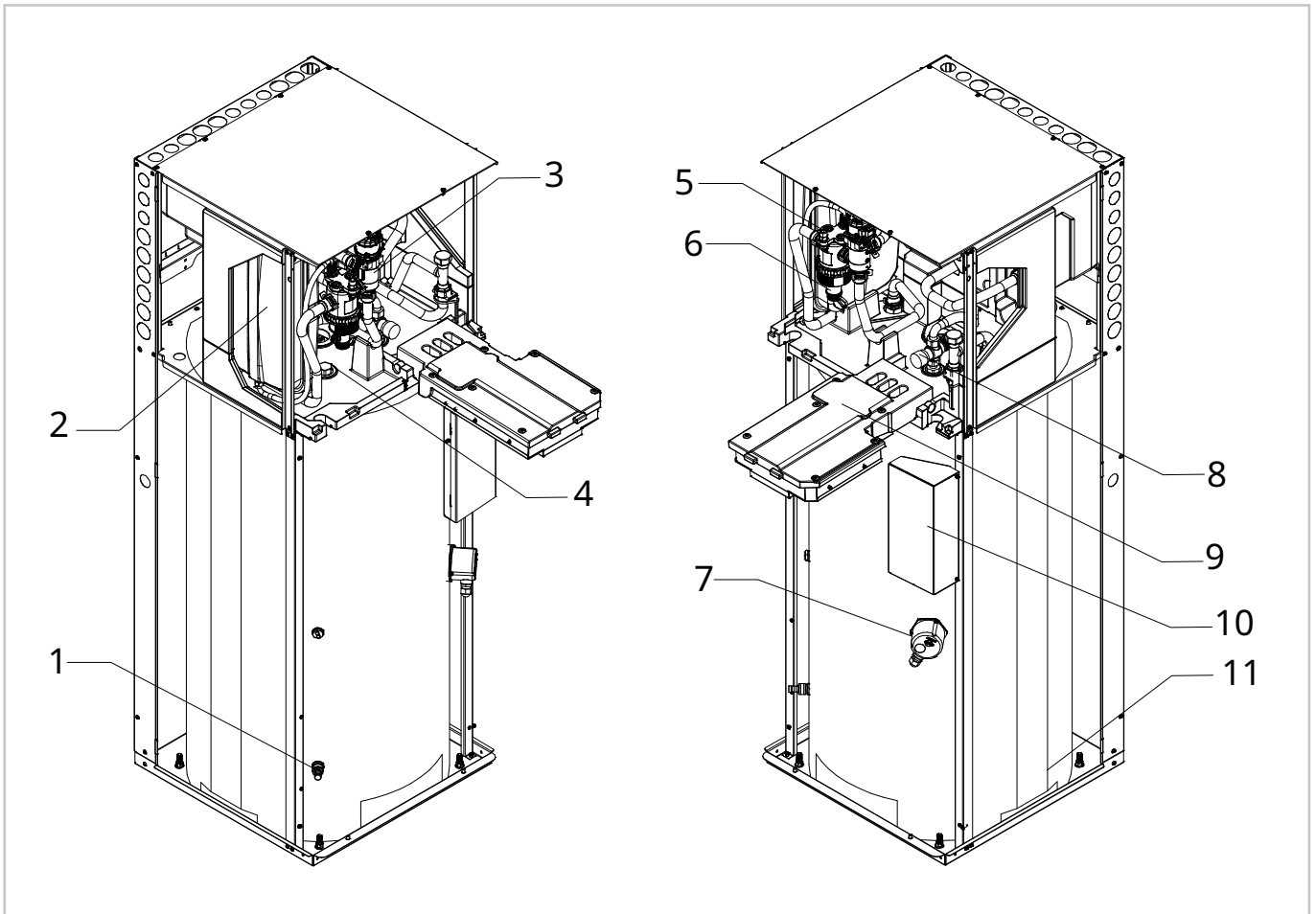

| No. | Component |
|-----|----------------------------|
| 1 | Storage tank drain tap |
| 2 | Expansion tank |
| 3 | 3-way valve |
| 4 | Electronic anode |
| 5 | Air relief valve |
| 6 | Sludge |
| 7 | Heating element 2kW |
| 8 | Anti-scalding valve |
| 9 | Main electrical panel |
| 10 | Secondary electrical panel |
| 11 | DHW tank |

 The images are provided for illustrative purposes only.

3.6 Components supplied with the unit

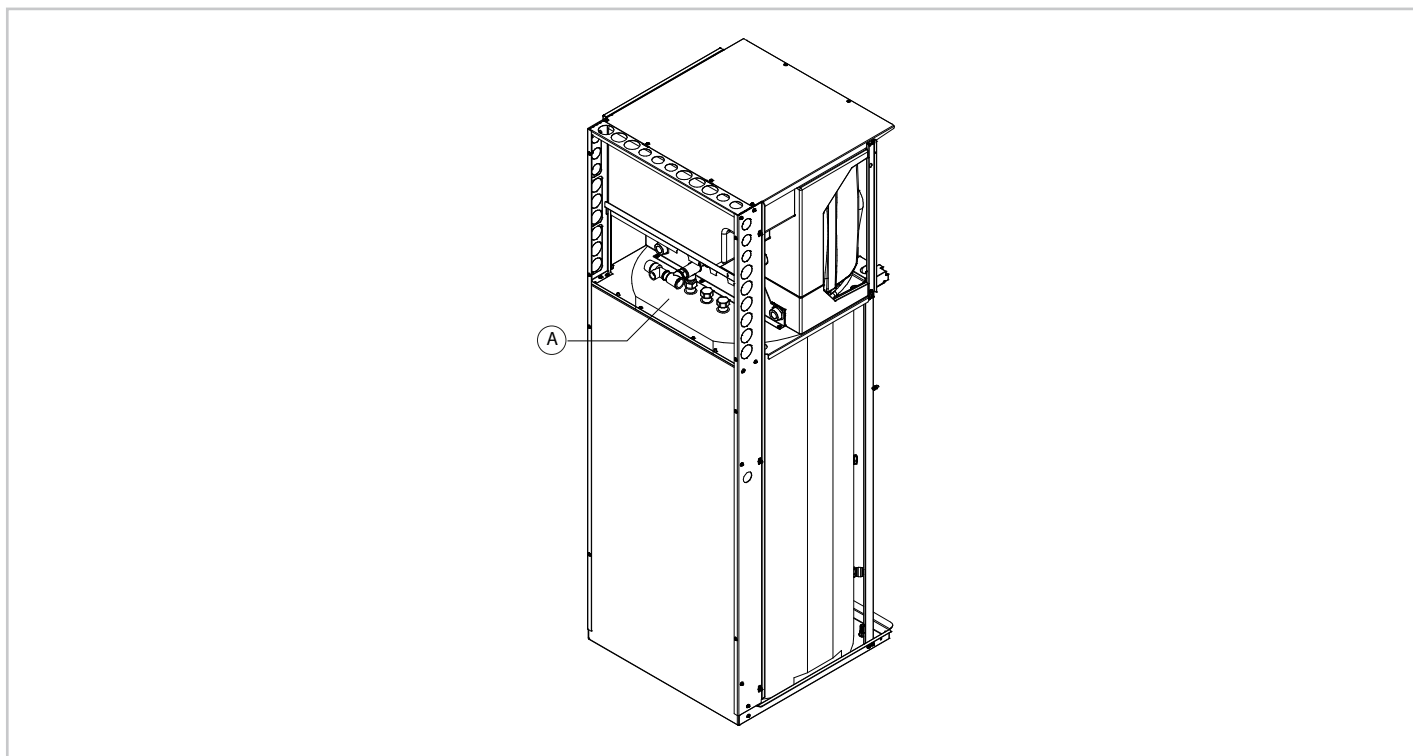

A Position of components supplied with the unit

The following components can be found in the package:

| Description | Quantity |
|-------------------------------------|----------|
| Installation and maintenance manual | 1 |
| TORX 1/4" insert | 1 |
| Quick-release fixing clip | 1 |
| Expansion tank gasket | 1 |
| O-ring | 1 |

3.7 Compatible accessories

The list of accessories can be found in the technical bulletin.

4. Before installation

4.1 Prerequisites

- ⚠ This section is intended exclusively for the Installer.
- ⚠ Refer to the Technical data chapter for details.
- ⚠ When handling the unit, use equipment appropriate to the weight of the unit.
- ⚠ Check that all handling equipment complies with local safety regulations (cran, forklifts, ropes, hooks, etc.).
- ⚠ During manual operations, it is mandatory to comply with the maximum weight per person as required by current legislation.
- ⚠ Provide personnel with personal protective equipment appropriate for the situation, such as hard hat, gloves, safety shoes, etc.
- ⚠ Observe all safety procedures in order to guarantee the safety of the personnel present and the of material.
- ⚠ Keep the unit packed during handling.
- ⚠ Remove the packaging when you have reached the point of installation.

4.2 Reception

Before accepting the delivery, check:

- that the unit has not been damaged during transport
- the slope indicator on the packaging is:
 - green dot ► OK, remove the packaging
 - red dot ► remove the packaging and visually check the unit

⚠ For returns see: In case of damage or fault

- that the materials delivered match those indicated on the transport document, comparing the data with the serial number label on the packaging.

In case of damage or anomaly:

- immediately write down the damage found on the transport document and quote this sentence: "Accepted with reservation due to evident shortages/damages during transport"
- refer to the contractual document.

ⓘ Any disputes must be made within 8 days from the date of the delivery. Complaints after this period are invalid .

Unit's slope indicator

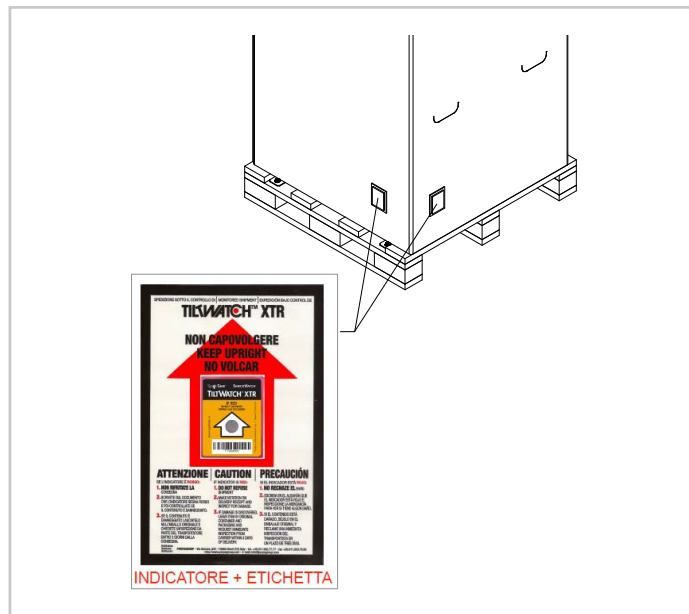

4.3 Storage

Respect the indications on the outside of the pack.

In particular:

- minimum ambient temperature -10 °C
- maximum ambient temperature +50 °C
- maximum relative humidity 95%

⚠ Exceeding these limits can cause irreversible damage to the unit.

4.4 Handling

The unit can be handled:

- with a forklift truck or pallet truck.

The following examples are guidelines; the choice of means and handling modes will depend on the actual installation situation.

4.4.1 Lifting with a forklift truck

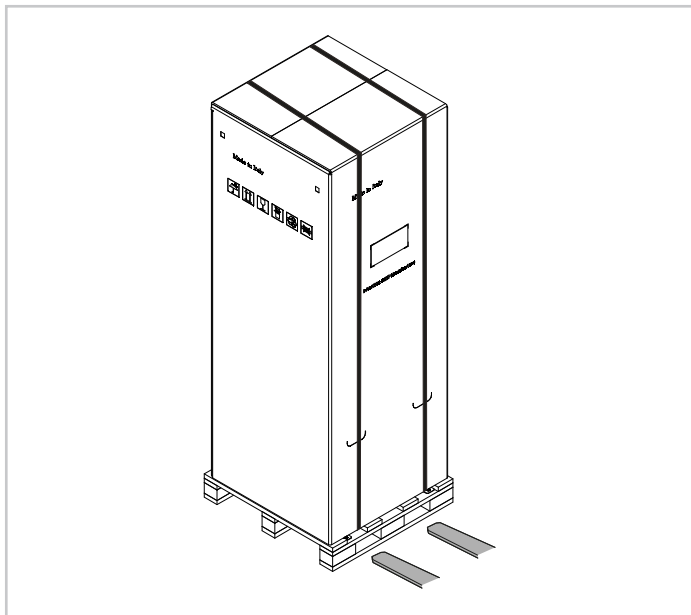

- ⚠ When the load is lifted off the ground, stay clear of the area below and around it.
- ⚠ Identify critical points during handling (disconnected routes, flights, steps, doors).
- ⚠ Before starting the handling, make sure that the unit is stable.

4.5 Removal of the packaging

On reaching the installation site.

Carry out the following procedure:

- ▶ cut the straps

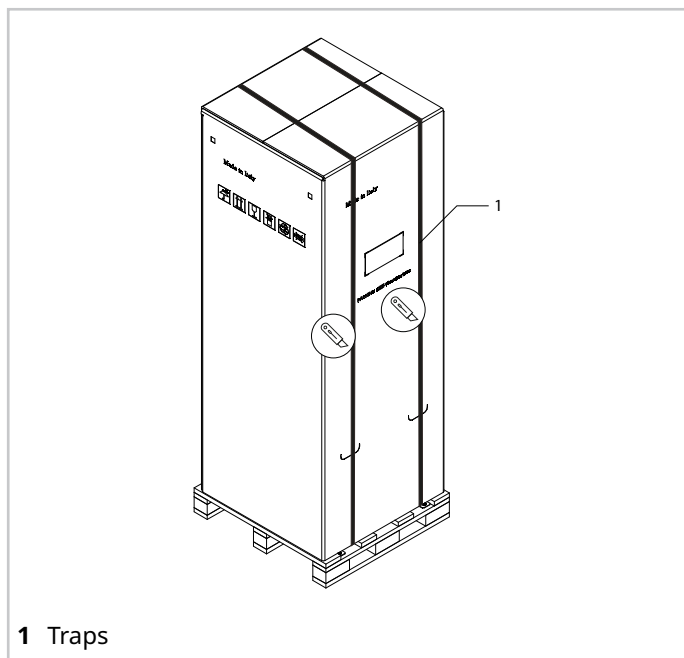

- ▶ lift and remove the packaging

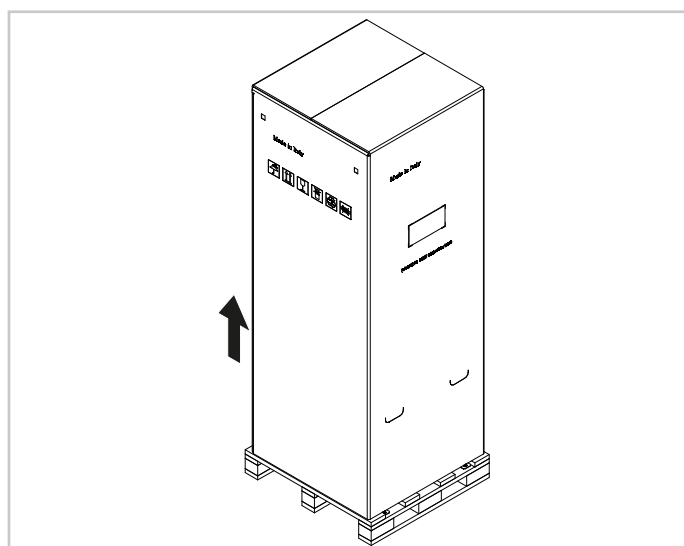

Before installation

- ▶ remove the protection elements
- ▶ remove the components supplied

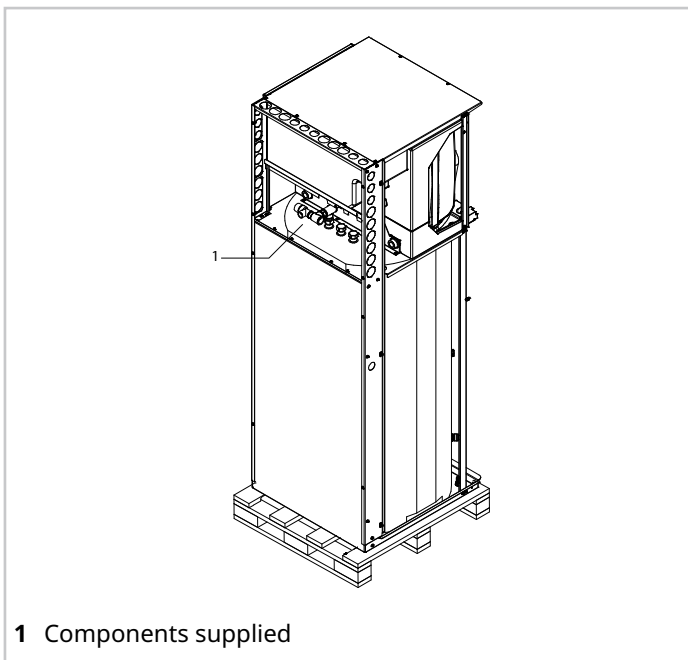

- ▶ remove the fixing screws from the pallet

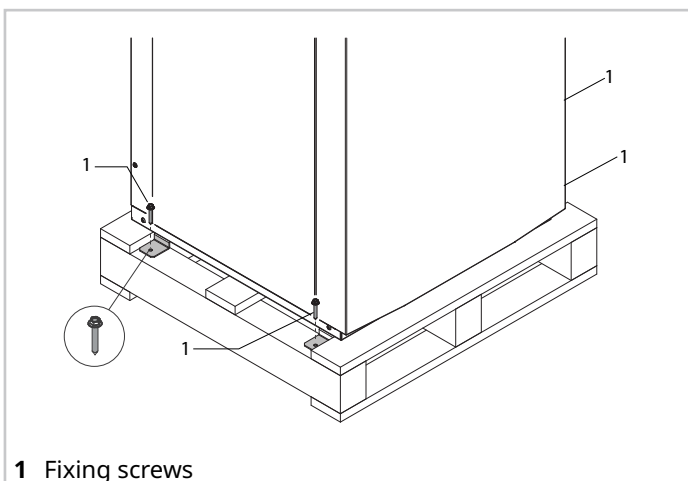

- ▶ move the brackets

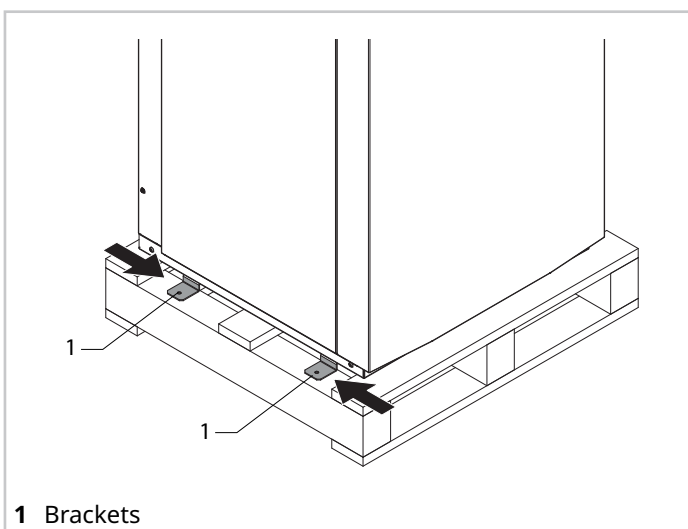

- ▶ remove the brackets
- ▶ remove the unit with suitable means

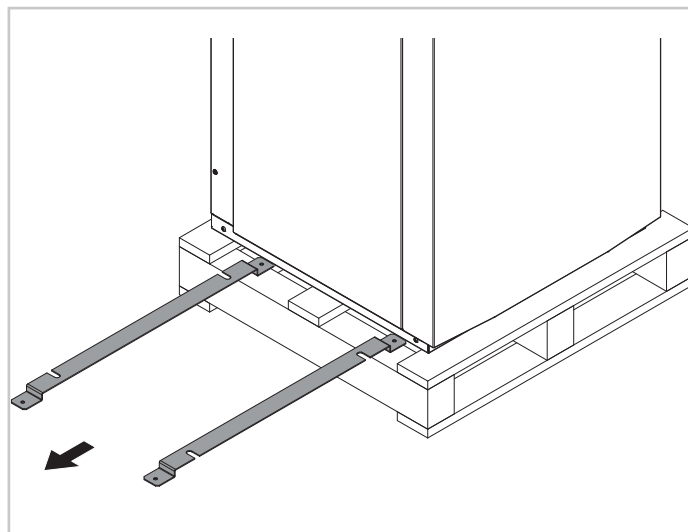

- ⚠ Be careful not to damage the unit.
- ⚠ Keep the packaging material out of children's reach as it may be dangerous.
- ♻ Recycle and dispose of the packaging material in conformity with local regulations.

5. Installation

5.1 Prerequisites

- ⚠ This section is intended exclusively for the Installer.
- ⚠ Refer to the Technical data chapter for details.
- ⚠ The electrical system and its components must be designed by a qualified technician who must work according to the rules of good practice and national regulations.
- ⚠ **Ensure that:**
 - the room or the compartment is dry and the room temperature cannot fall below 0°C or rise above 35°C
 - any furniture or other objects can be moved easily in the event of maintenance
 - the location can be accessed safely
 - the clearances are guaranteed
 - the support surface or the wall can withstand the weight of the unit
 - the floor or wall section does not interfere with power lines or water piping and no load-bearing elements of the construction are compromised.
- ⚠ **Avoid therefore:**
 - places that may be subject to flooding

5.2 General diagram

Place the unit on a flat surface.

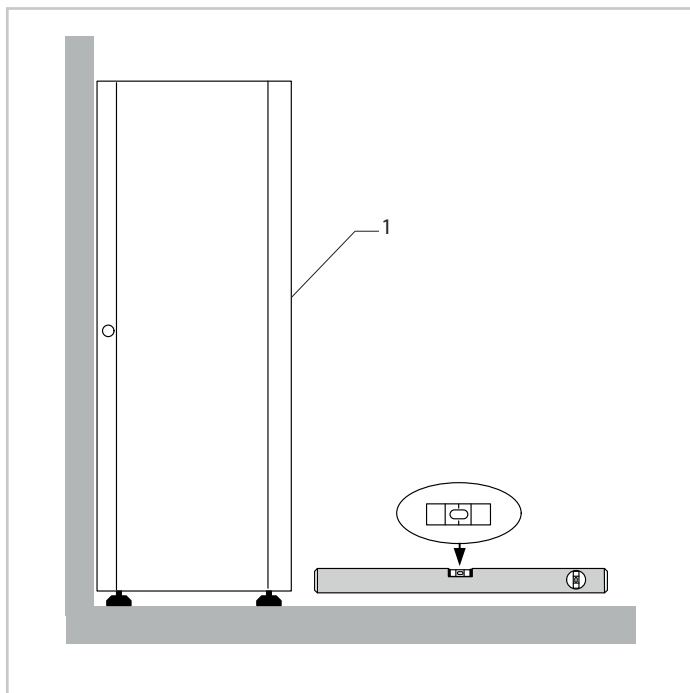

Levelling internal unit

► adjust the support feet

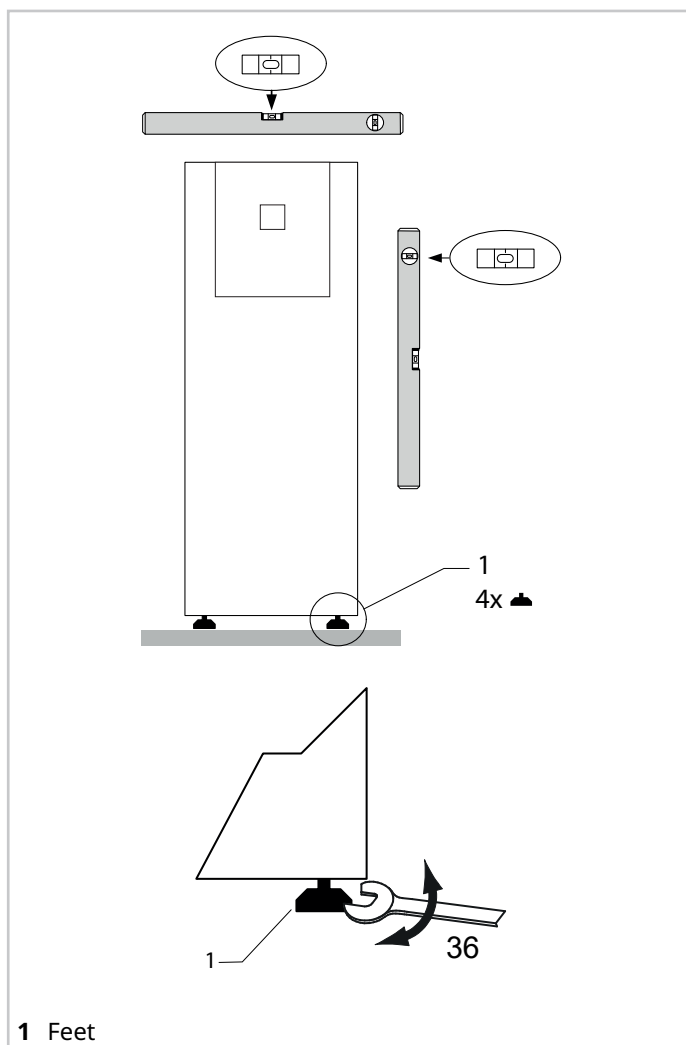

5.3 Clearances

The clearances for installation and maintenance of the unit are shown in the figure.

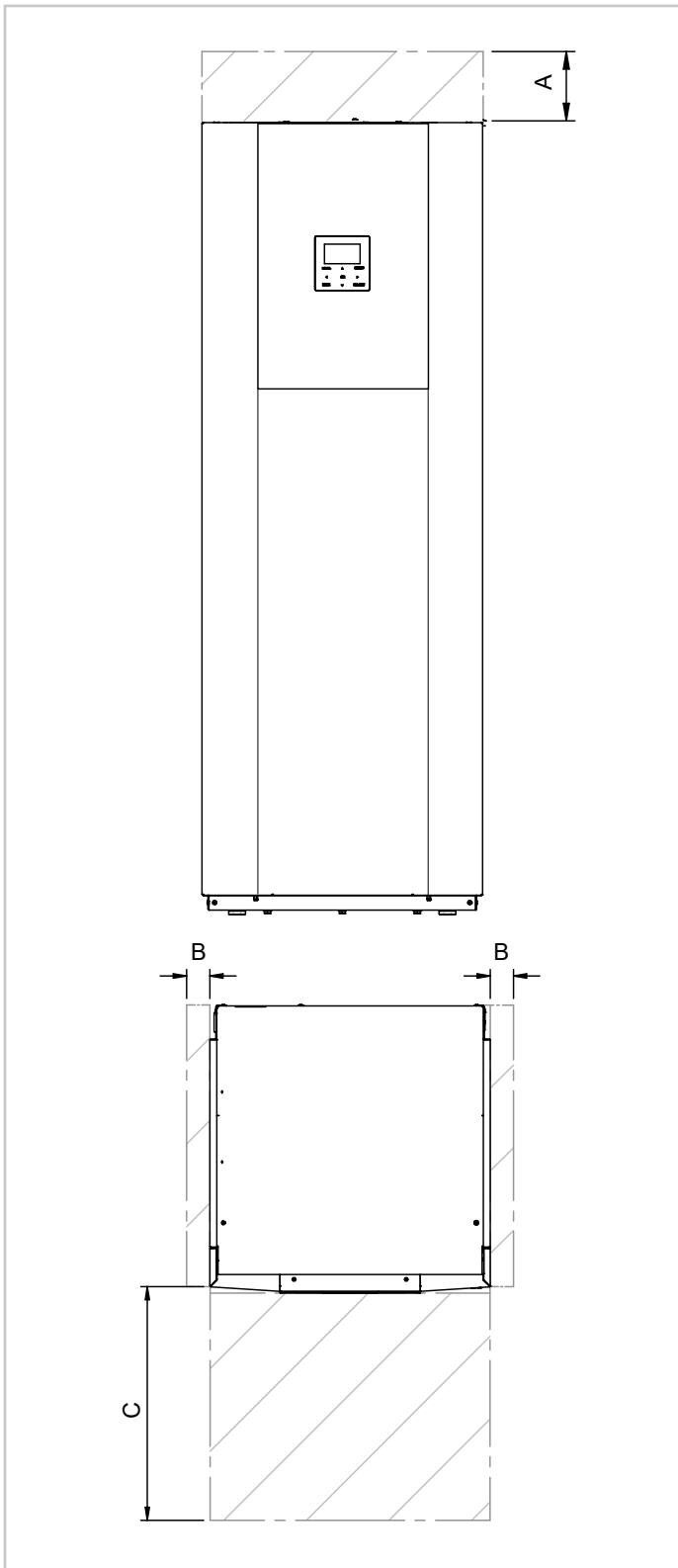

5.4 Access to internal parts

The unit has removable access panels.

To access the unit:

- unscrew the fixing screws

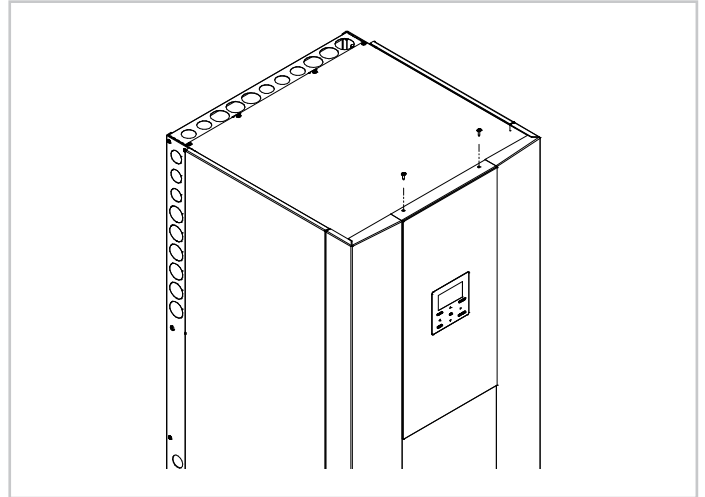

- remove the access panel

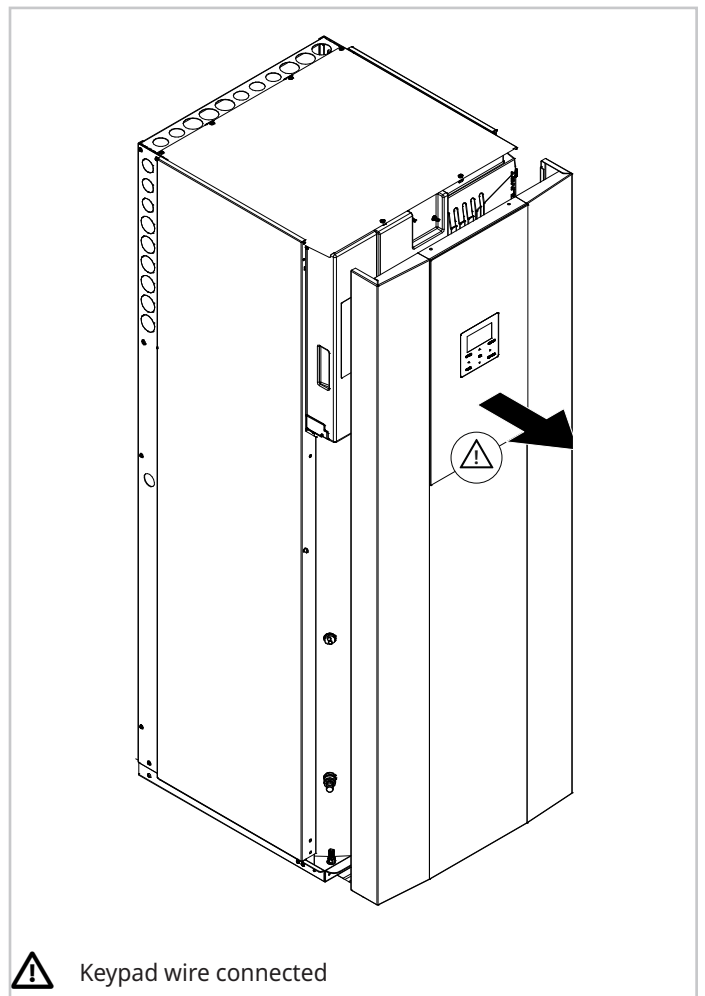

Cable inlet:

- remove the panel

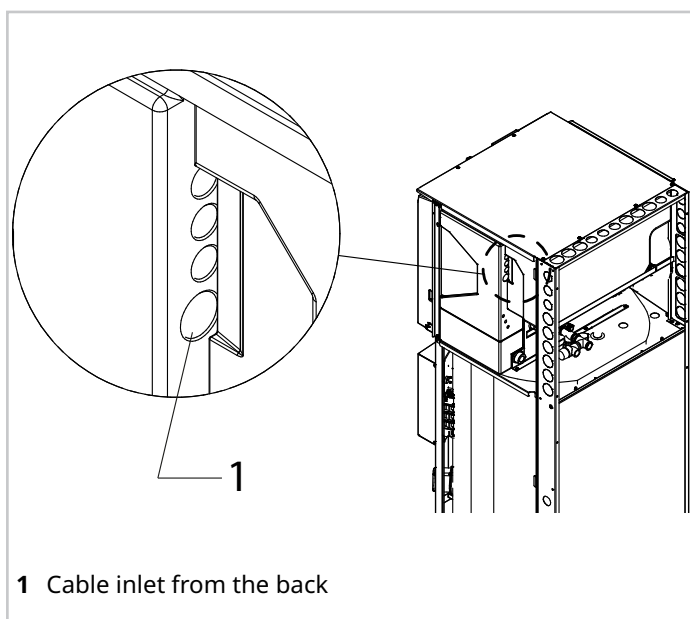
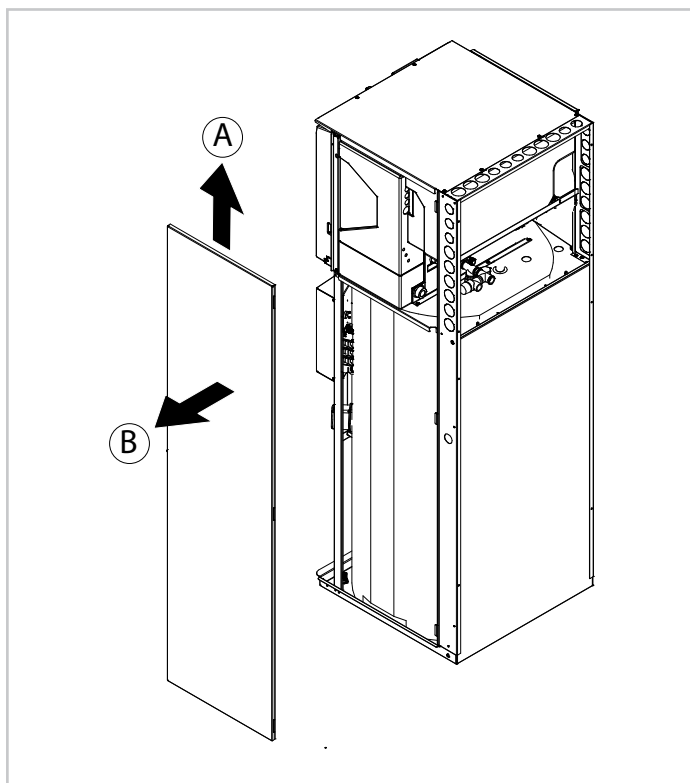

To access the electrical panel:

- remove the protection panel

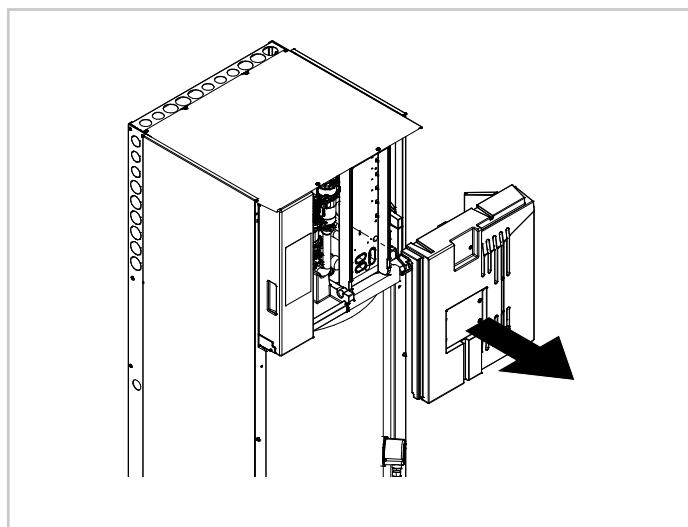

To access the components behind the electrical panel

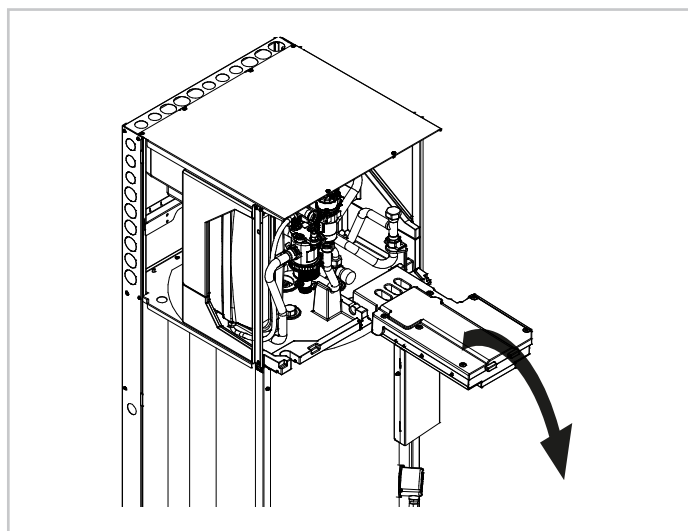

To refit:

- repeat the operations in reverse order

6. Water connections

6.1 General system diagram Standard

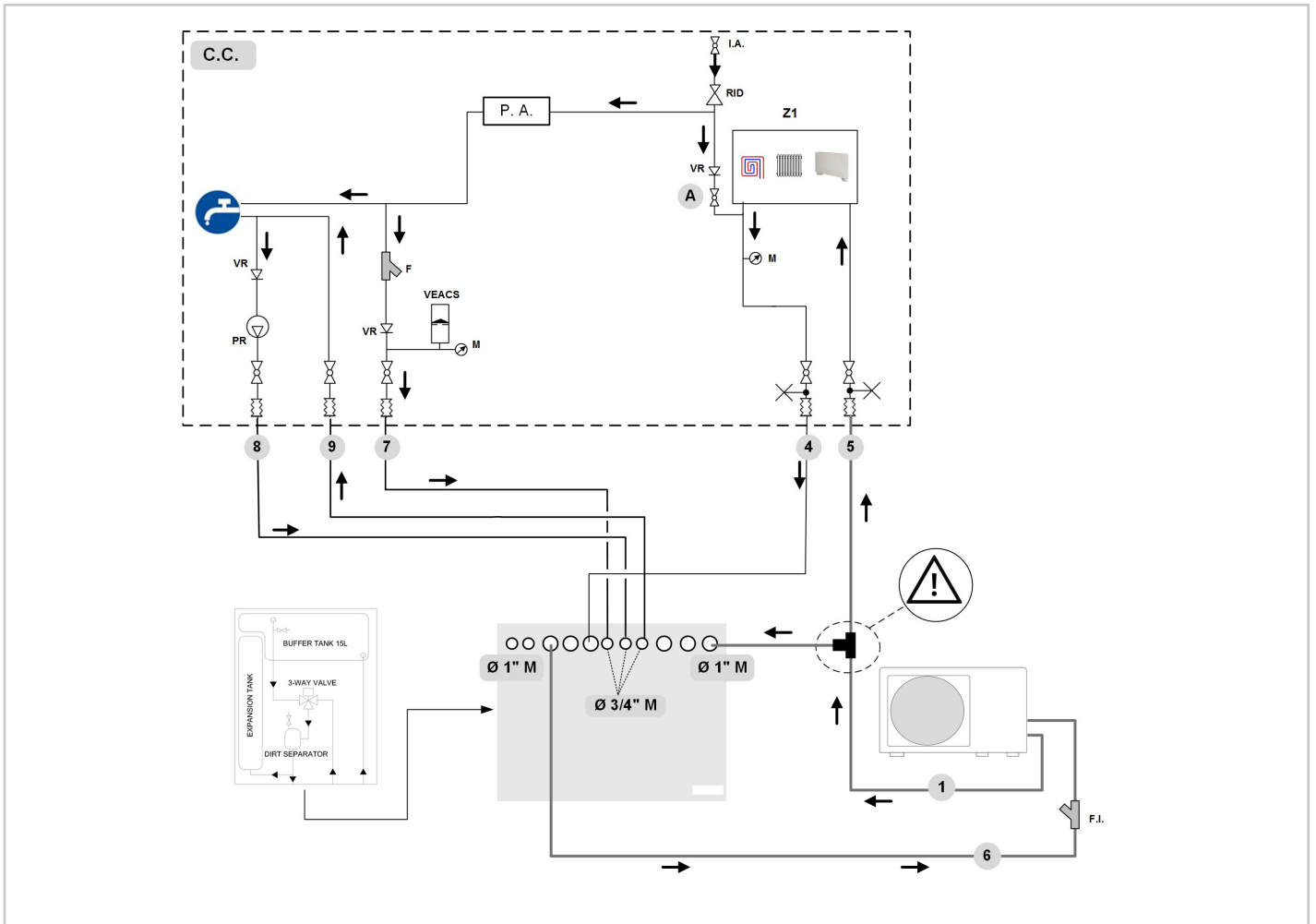

Indispensable components system (not supplied)

| | | | |
|------|---|---|---------------------------------|
| C.C. | Components provided by Customer | 1 | Water supply from outdoor unit |
| A | System valve | 4 | Water return from area 1 system |
| I.A. | Aqueduct inlet | 5 | Water supply to area 1 system |
| F | Water filter (to be provided by customer) | 6 | Water return to outdoor unit |
| F.I. | System filter (standard supplied) | 7 | Aqueduct inlet |
| M | Pressure gauge | 8 | DHW recirculation |
| P.A. | Descaler protection | 9 | DHW outlet |
| RID | Pressure reducing valve | | Vent |
| VR | Check valve | | Cut-off valves |
| Z1 | Zone 1 | | Anti-vibration joints |

Use the "T" fitting in the supplied kit by installing it on the water supply of the outdoor unit.

Do NOT use the "T" connection when using the electrical resistance option.

6.2 General system diagram

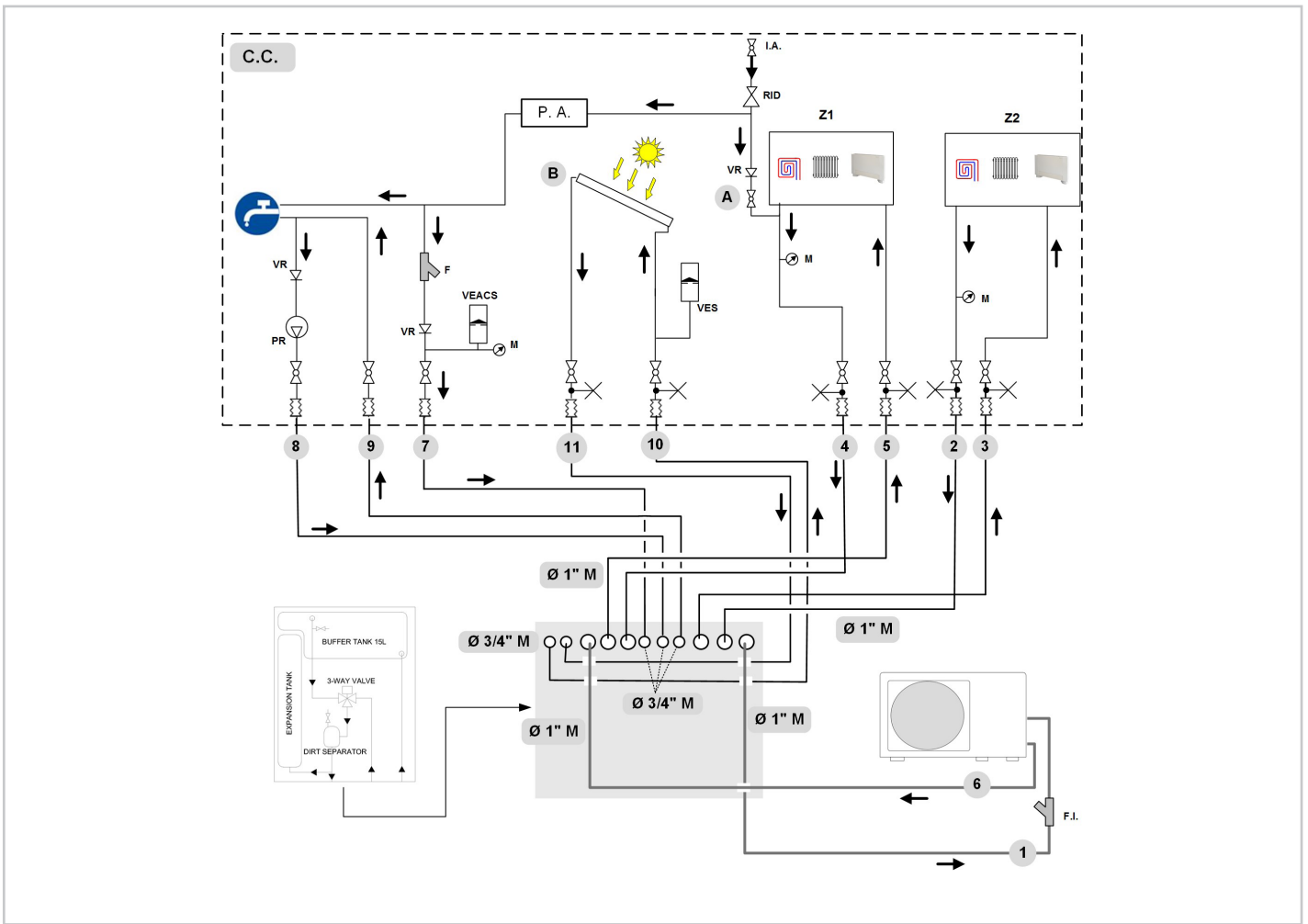

Indispensable components system (not supplied)

| | | | |
|-------------|---|----|--|
| C.C. | Components provided by Customer | 1 | Water supply from outdoor unit |
| A | System valve | 2 | Water return from area 2 system (optional) |
| B | ELFOSun2 (option) | 3 | Water supply to area 2 system (optional) |
| I.A | Aqueduct inlet | 4 | Water return from area 1 system |
| F | Water filter (to be provided by customer) | 5 | Water supply to area 1 system |
| F.I | System filter (standard supplied) | 6 | Water return to outdoor unit |
| M | Pressure gauge | 7 | Aqueduct inlet |
| P.A | Descaler protection | 8 | DHW recirculation |
| PS | Solar pump | 9 | DHW outlet |
| RID | Pressure reducing valve | 10 | Solar system return (option) |
| VES | Solar expansion tank | 11 | Solar system outlet (option) |
| VR | Check valve | | Vent |
| Z1 | Zone 1 | | Cut-off valves |
| Z2 | Zone 2 | | Anti-vibration joints |

i Refer to the combined outdoor unit manual for:

- Prerequisites
- Water flow-rate
- Minimum water content
- Water characteristics
- Cleaning
- Piping insulation
- Hydraulic circuit antifreeze protection

6.3 Position of connections

Rear view.

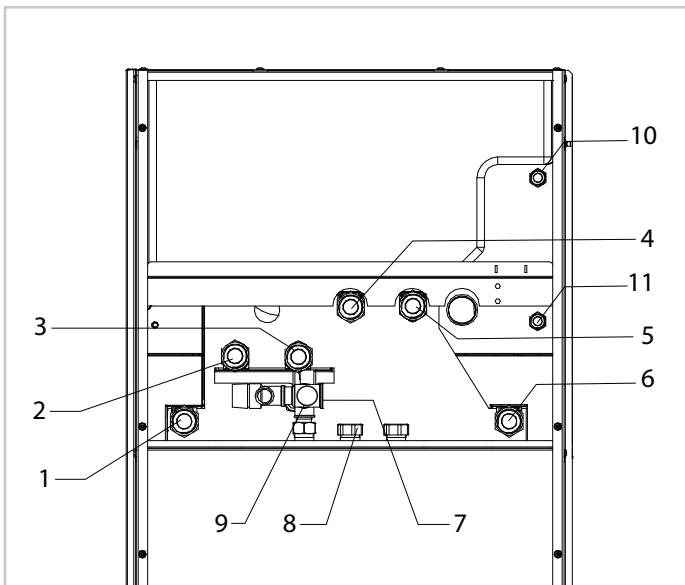

- 1** Water supply from outdoor unit 1"
- 2** Area 2 system return - 1" (optional)
- 3** Area 2 system supply - 1" (optional)
- 4** Area 1 system return - 1"
- 5** Area 1 system supply - 1"
- 6** Water return to outdoor unit 1"
- 7** Water supply system inlet 3/4"
- 8** DHW recirculation 3/4"
- 9** DHW outlet 3/4"
- 10** Supply to solar system 3/4" (optional)
- 11** Return from solar system 3/4" (optional)

Top pipes outlet

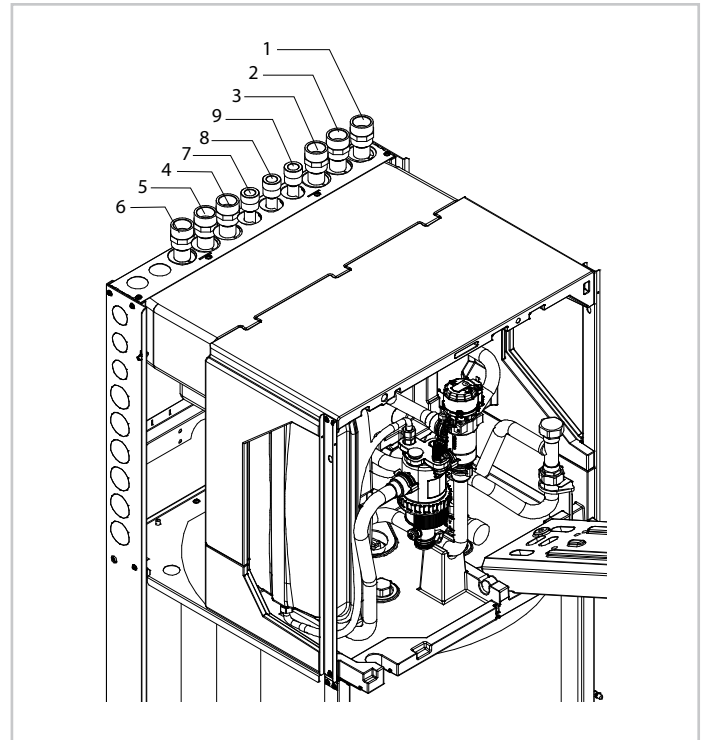

If the top space is insufficient, connections can be made from the left or right side of the unit through the necessary pre-cuts.

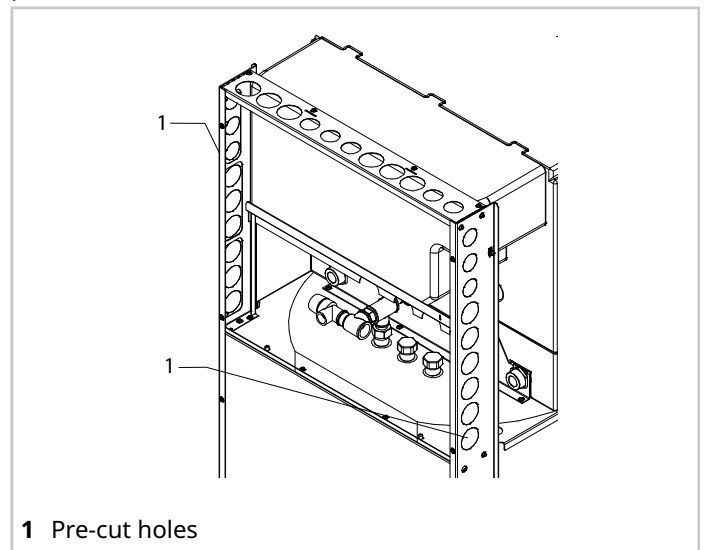

6.4 Hydraulic connection

Ensure that:

- clean piping with no moisture, air, dirt or dust is used
- the end of the pipe is kept downwards when removing burrs
- the end of the pipe is covered when passing it through a wall to prevent dust and dirt from entering
- thread sealant is used to seal the connections that must withstand the pressures and temperatures of the circuit
- the two types of materials are isolated from each other to

prevent galvanic corrosion when using non-copper metal piping

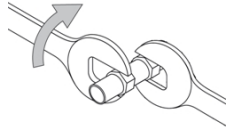

- the piping is not deformed by using excessive force or unsuitable tools during connection: this could cause the unit to malfunction.

 Always use the wrench and counter wrench method in tightening operations.





6.5 Water filter

A water filter is supplied with the unit.

-  Installation of the filter is mandatory.
-  Operation without a filter can cause irreversible damage to the unit.
-  Operation without a filter will void the warranty.

Remember that the filter must be:

- installed immediately at inlet to the water supply system
- easily accessible for maintenance work

-  Periodically check for clogging.
-  The filter should never be removed.

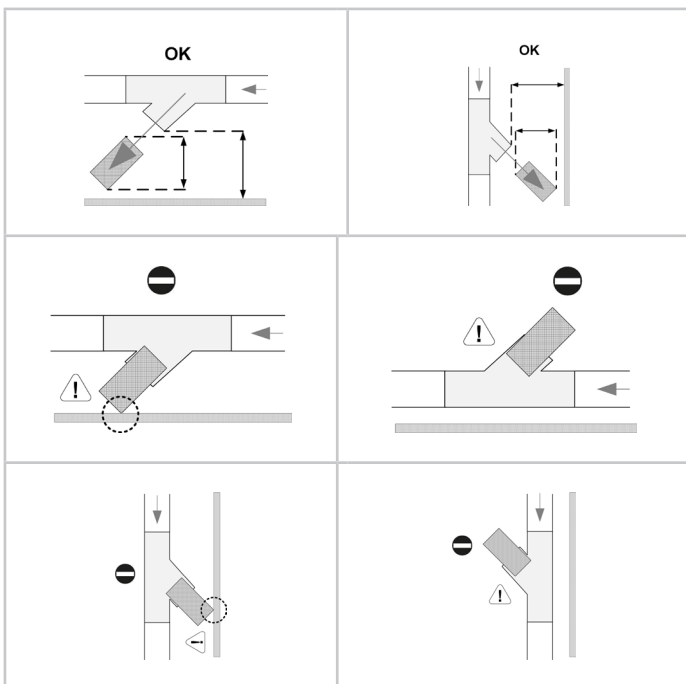

otherwise if valves intervened and flood the rooms, the heat pump manufacturer will not be responsible.

Pressure relief valve connection

- ▶ connect the pipe to the pressure relief valve
- ▶ direct the exhaust pipe towards a suitable drain

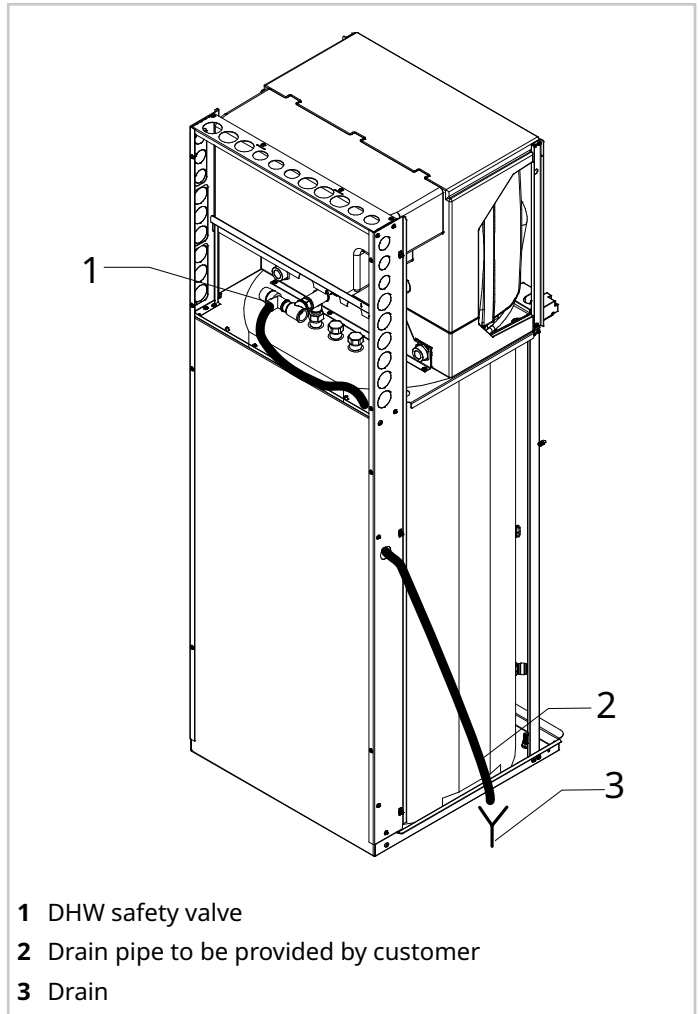

6.6 DHW safety valve

 Inside the unit there is a safety valve (6 bar on the DHW circuit) that must be connected to a suitable drain,

6.7 DHW tank filling

Once the hydraulic connections have been completed, the DHW tank can be filled.

DHW tank filling:

- ▶ system's main switch OFF
- ▶ close the drain valve
- ▶ start filling, open the filling tap on the system (refer to the General system diagram)

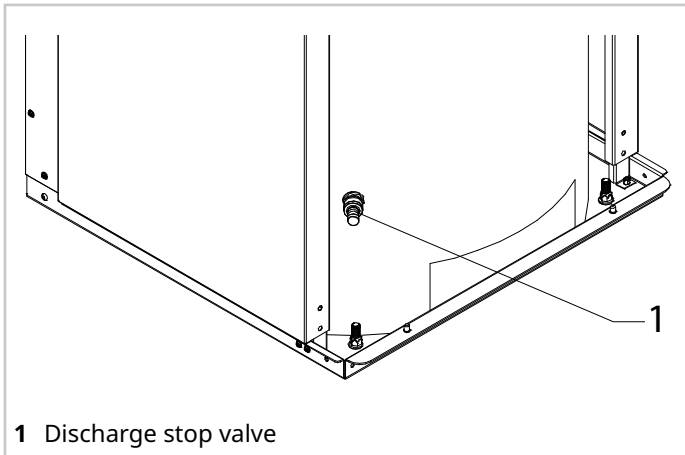

- ▶ open the taps located on the system and connected to the DHW outlet, DHW recirculation inlet and water inlet
- ▶ open the hot water taps (bathroom and kitchen)

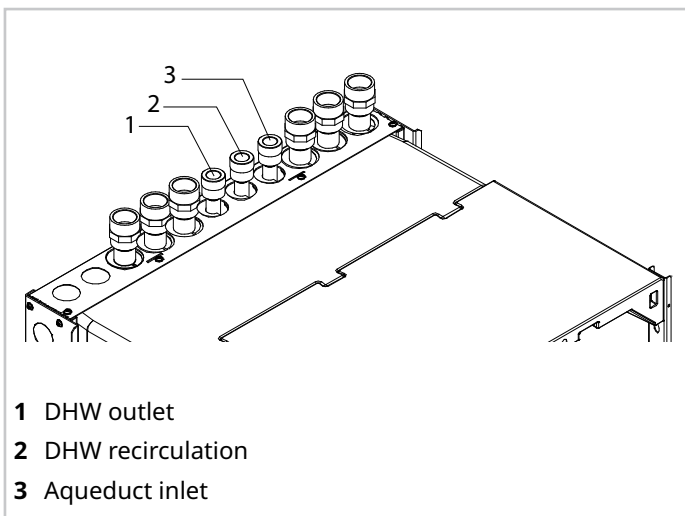

When water starts coming out of the taps:

- ▶ close the taps
- ▶ continue filling up to the system pressure value
- ▶ check the hydraulic seal of the joints

⚠ Maximum DHW system pressure 6 bar

⚠ DHW safety valve setting 6 bar

6.8 Loading the plant

Once the hydraulic connections have been completed, the

system can be charged.

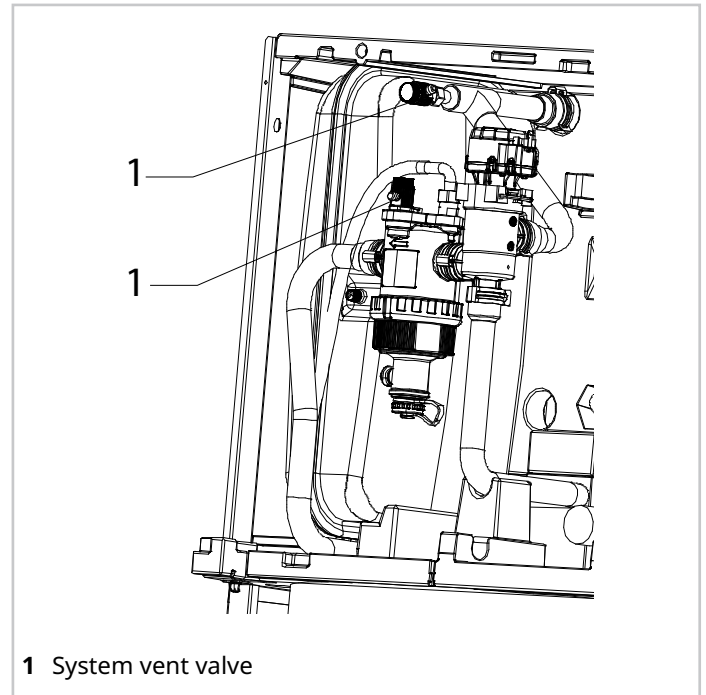

Charging the system:

- ▶ open the filling tap on the system (refer to the General system diagram)
- ▶ open all of the system and terminal relief valves

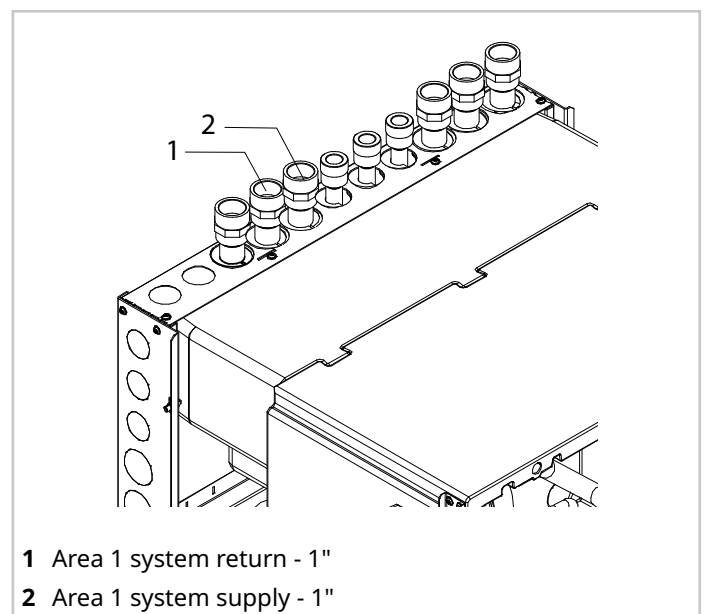

When water starts coming out of the air relief valves:

- ▶ close the valves
- ▶ continue filling up to the system pressure
- ▶ check the hydraulic tightness of the connections.





























⚠ Check the system pressure periodically.

⚠ Reintegration is carried out when the unit is off (pump OFF).

-  If the system remains charged and inoperative at outside temperatures close to zero, freezing problems may occur.
-  Refer to the Hydraulic Circuit Frost Protection chapter.
-  In case of extraordinary maintenance see chapter MAINTENANCE.

7. Electrical connections

7.1 Prerequisites

-  This section is intended exclusively for the Installer.
-  The electrical system and its components must be designed by a qualified technician who must work according to the rules of good practice and national regulations.
-  All electrical operations should be performed by trained personnel having the necessary requirements by the regulations in force and being informed about the risks relevant to these activities.
-  Operate in compliance with safety regulations in force.
-  The power cables and the protection cable section must be defined in accordance with the characteristics of the protections adopted.
-  The protection devices of the unit power line must be able to stop the presumed short circuit current, whose value must be determined in function of system features.
-  Refer to the unit electrical diagram (the number of the diagram is shown on the serial number label).
-  verify that the network has characteristics conforming to the data shown on the serial number label.
-  Before starting work, verify that the sectioning device at the start of the unit power line is open, blocked and equipped with cartel warning.
-  The supply line must be disconnectable from the rest of the building's power mains with an all-pole magnetothermic circuit breaker with separation of contacts on all poles, to be implemented in accordance with current laws and regulations.
-  The protection must be sized in accordance with the electrical data declared by the manufacturer.
-  Disconnect the power supply before making any connection.
-  Do not crush cable bundles and prevent them from coming into contact with piping and any sharp edges.
-  Primarily you have to realize the earthing connection.
-  Incorrect grounding may cause electric shocks.
-  All external high voltage loads, if connected to a metal fitting or grounding clip, must be earthed.
-  The current required for each external load must be less than 0.2 A. If the current required for a single load is greater than 0,2 A, insert a contactor for control.
-  Install an earth leakage breaker (30 mA).
-  Failure to observe this precaution may result in electric shocks.
-  Power and signal cables should be routed as separately as possible to avoid any interference.
-  Keep the unit's controller wiring as far away from hot surfaces as possible. It is advisable to use cables with cross-linked polyvinyl chloride sheath.
-  For the electrical connection, use a cable of sufficient length to cover the entire distance without any connection work. Do not use extension cords. Do not apply other loads on the power supply.
-  If the power cable is damaged, it must be replaced by qualified personnel and in accordance with current national regulations.
-  The manufacturer is not liable for any damage caused by failure to install a grounding system or failure to comply with the diagrams.
-  Check the voltage values which must be within the limits: 220-240V +/- 10% and 380-415V +/- 6%.
-  Before power the unit, make sure that all the protections that were removed during the electrical connection work have been restored.
-  It is forbidden to connect the earth wire to gas or water pipes, lightning rods or telephone ground.

7.2 Cable inlet

To access the panel, see the "Access to internal parts" section

⚠ Before removing the protection panel from the electrical panel, disconnect the power supply to the indoor and outdoor units and to all the other electrically powered components.

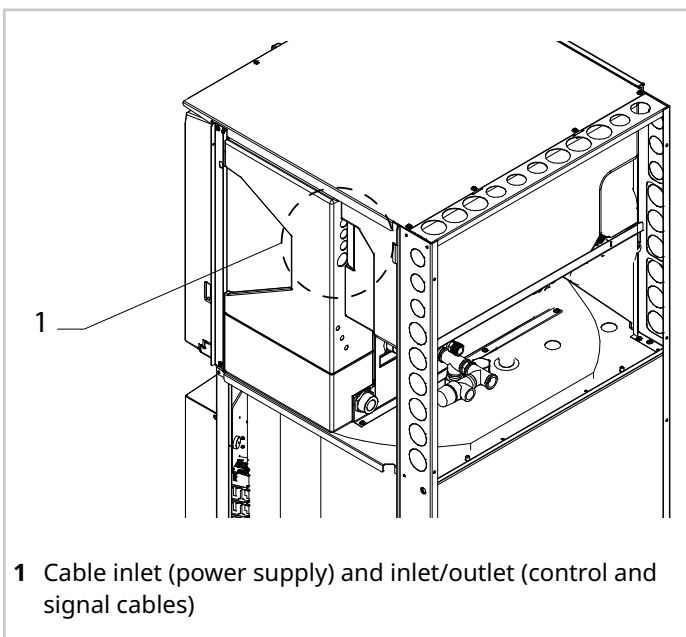
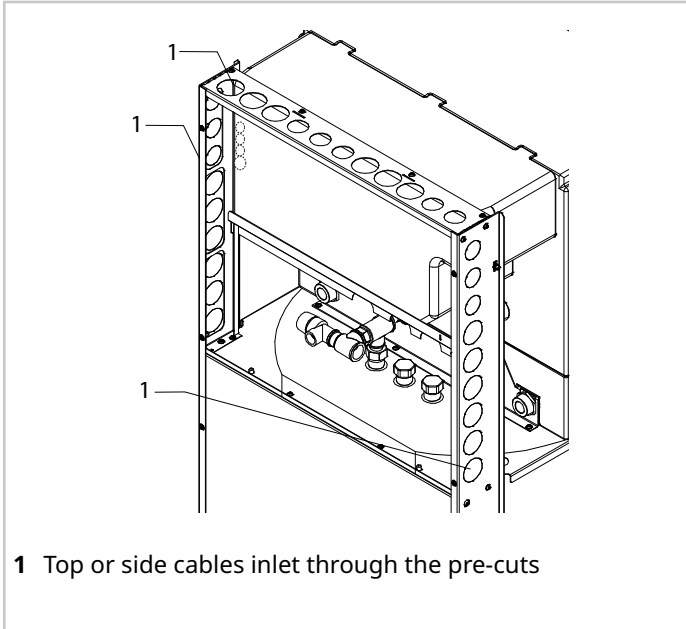

Cable entry in the electrical panel

The connection cables are plugged into the back of the electrical panel.

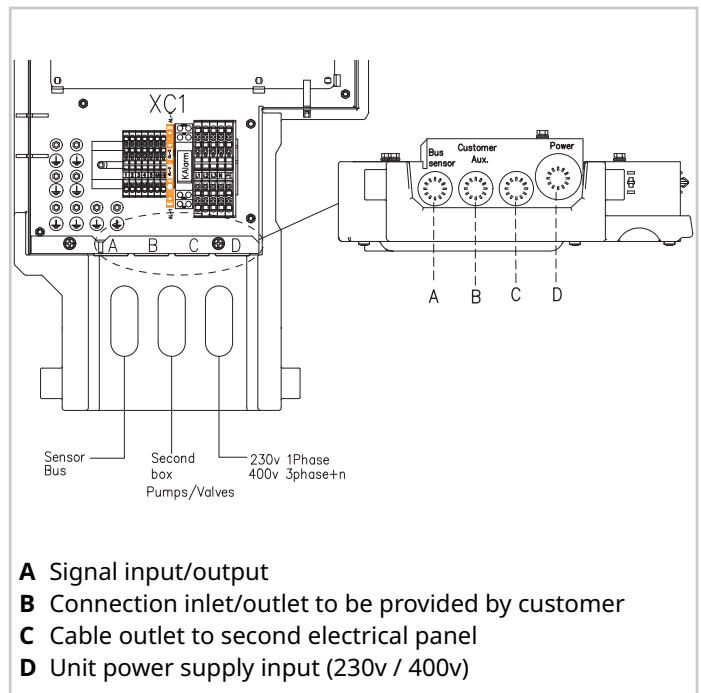
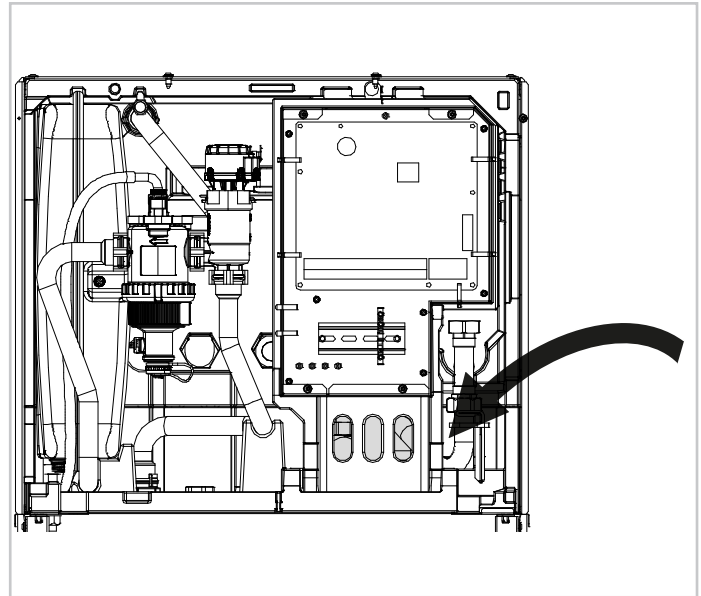

Secondary electrical panel

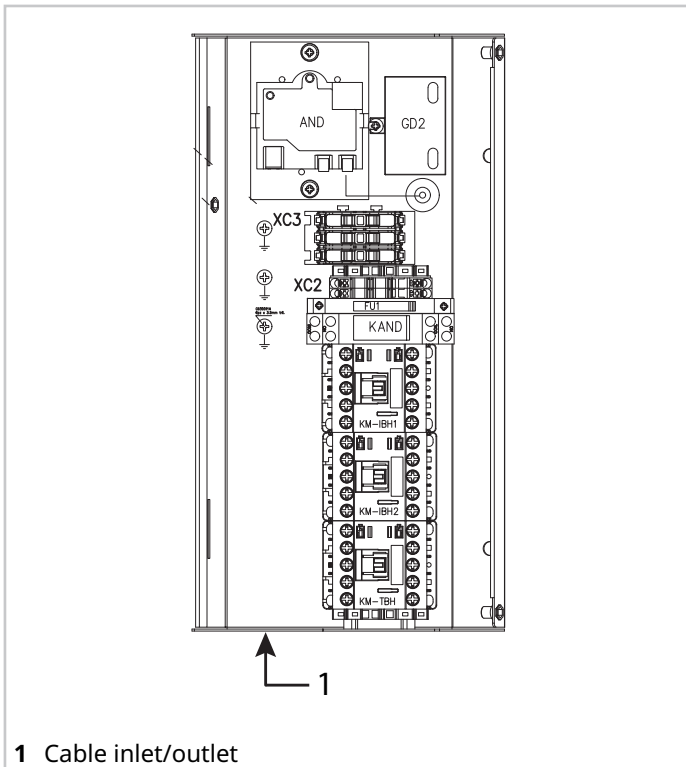
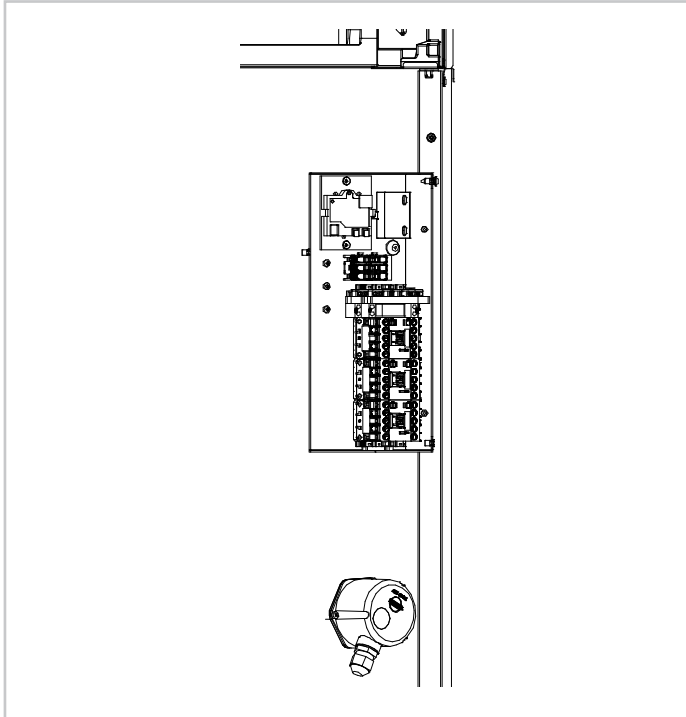

1 Cable inlet/outlet

⚠ Connect as shown in the wiring diagrams.

7.3 Connecting the power supply

⚠ Ensure that:

- no cables of different cross-sections are connected to the same power supply terminal block (loosening of the power supply wires could cause overheating)
- terminal block screws are not over-tightened
- an earth leakage breaker and a fuse or magnetothermic circuit breaker are connected to the supply line.

7.3.1 Single-phase units

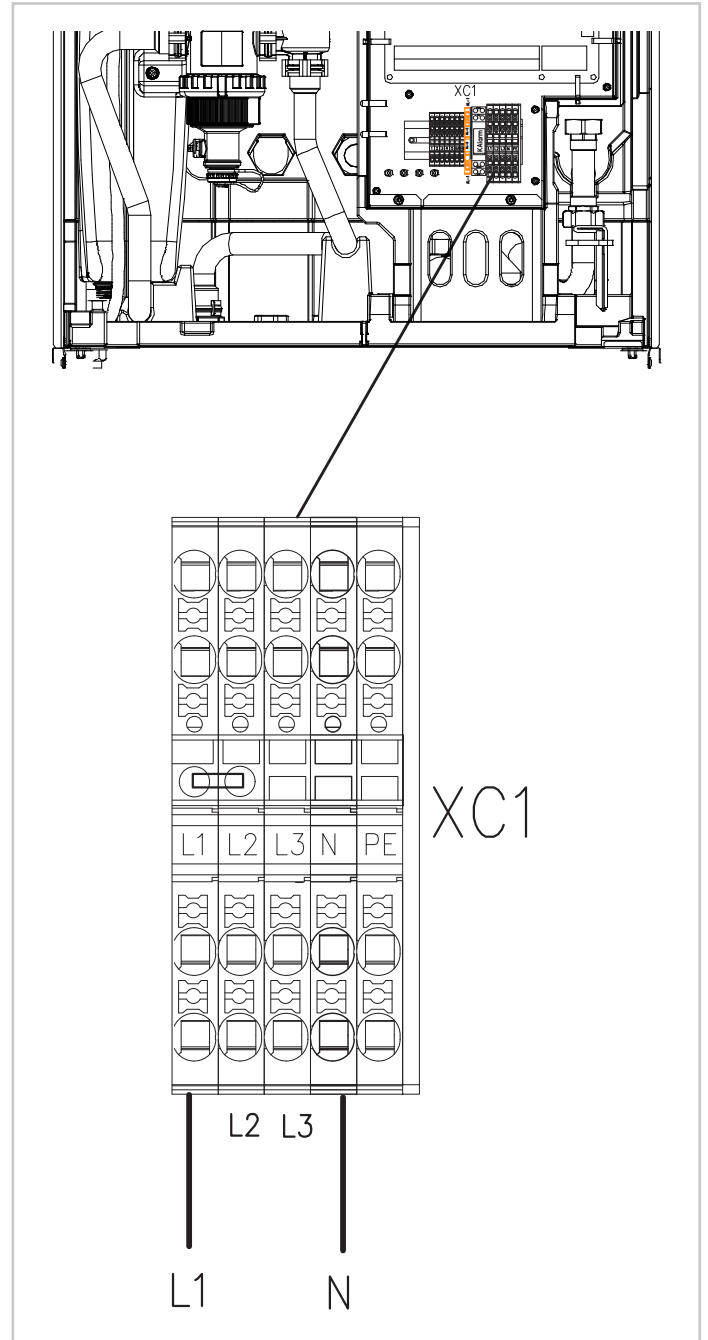

7.3.2 Three-phase units

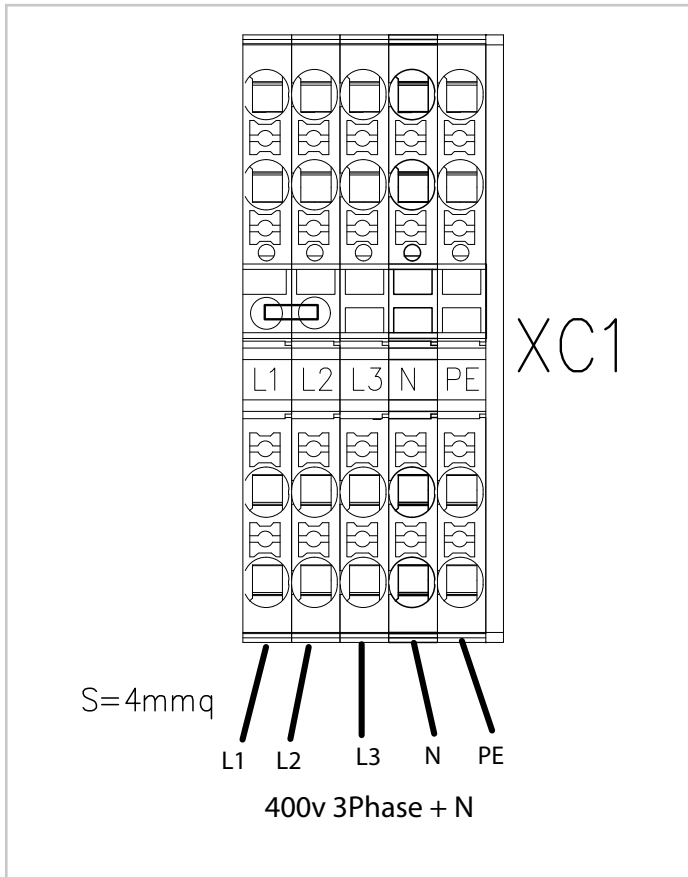

7.4 External component connections

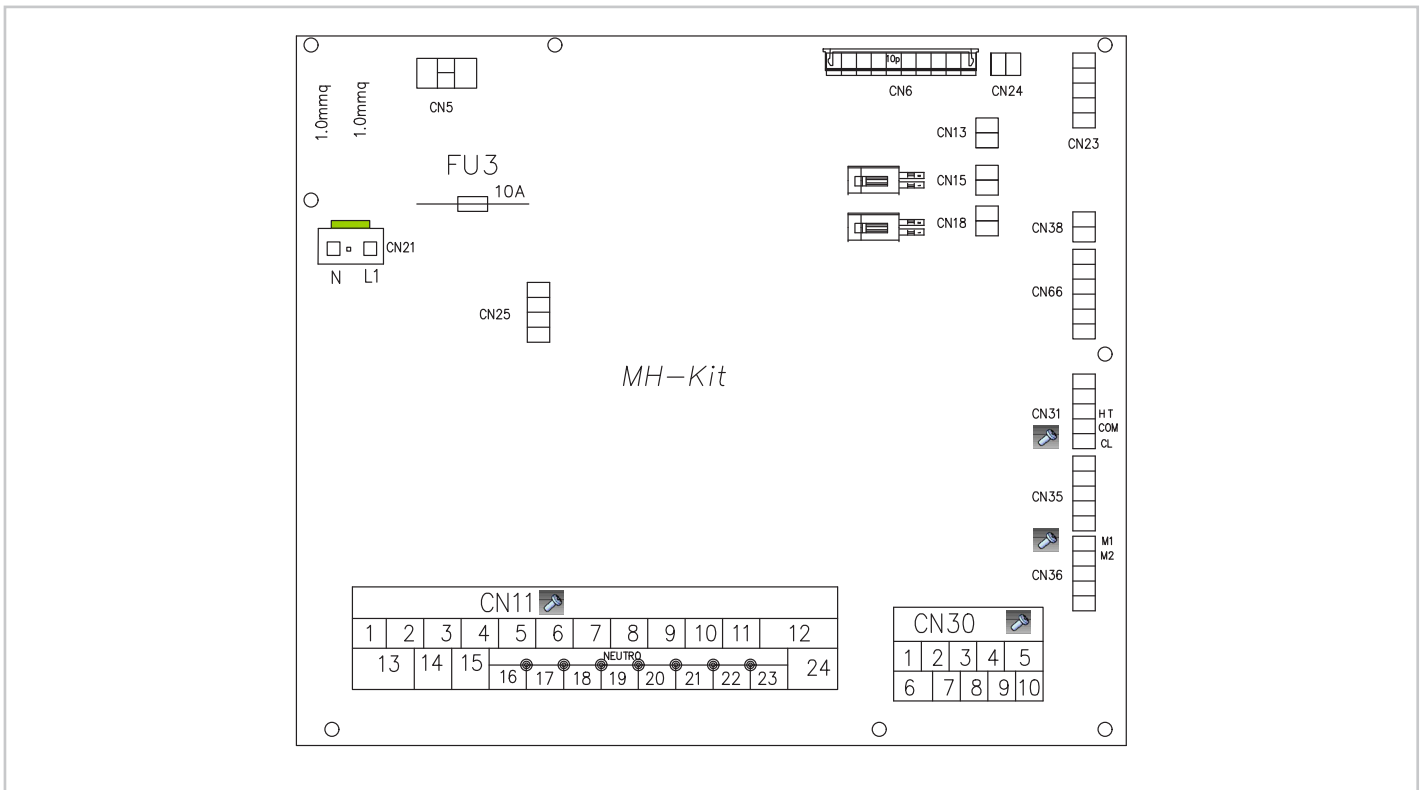

| Ref. | Terminal block CN11 | | | 220-240 VAC |
|------|---------------------|---------|----------------------------------|--------------------|
| 1 | 3 | SV1 ON | SV1 DHW 3-way valve | Contact en tension |
| | 4 | SV1 OFF | | |
| | 17 | N | | |
| 2 | 7 | SV3 ON | SV3 Zone 2 3-way mixing valve | Contact en tension |
| | 5 | SV2 ON | | |
| | 18 | N | | |
| 3 | 9 | P_c | pump P_c (zone2) | Contact en tension |
| | 19 | N | | |
| 4 | 10 | P_o | Pump P_o (zone1) | Contact en tension |
| | 20 | N | | |
| 5 | 11 | P_s | Solar pump | Contact en tension |
| | 21 | N | | |
| 6 | 12 | P_d | DHW recirculation pump | Contact en tension |
| | 22 | N | | |
| 7 | 13 | TBH | TBH heater | Contact en tension |
| | 16 | N | | |
| 8 | 14 | IBH1 | External backup heater | Contact en tension |
| | 16 | N | | |

i See the glossary for the acronyms

7.5 Keypad + bus connection

R-290 unit

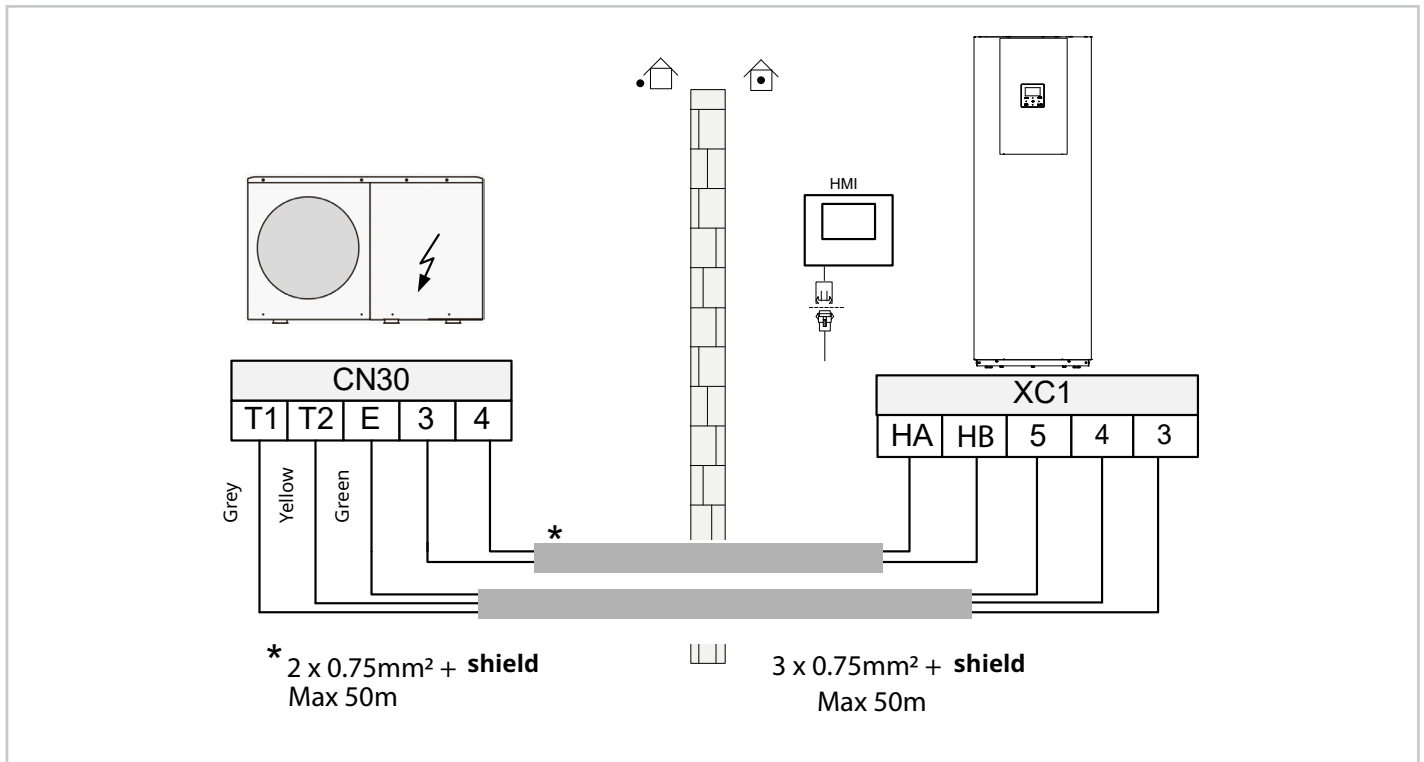

R-32 unit

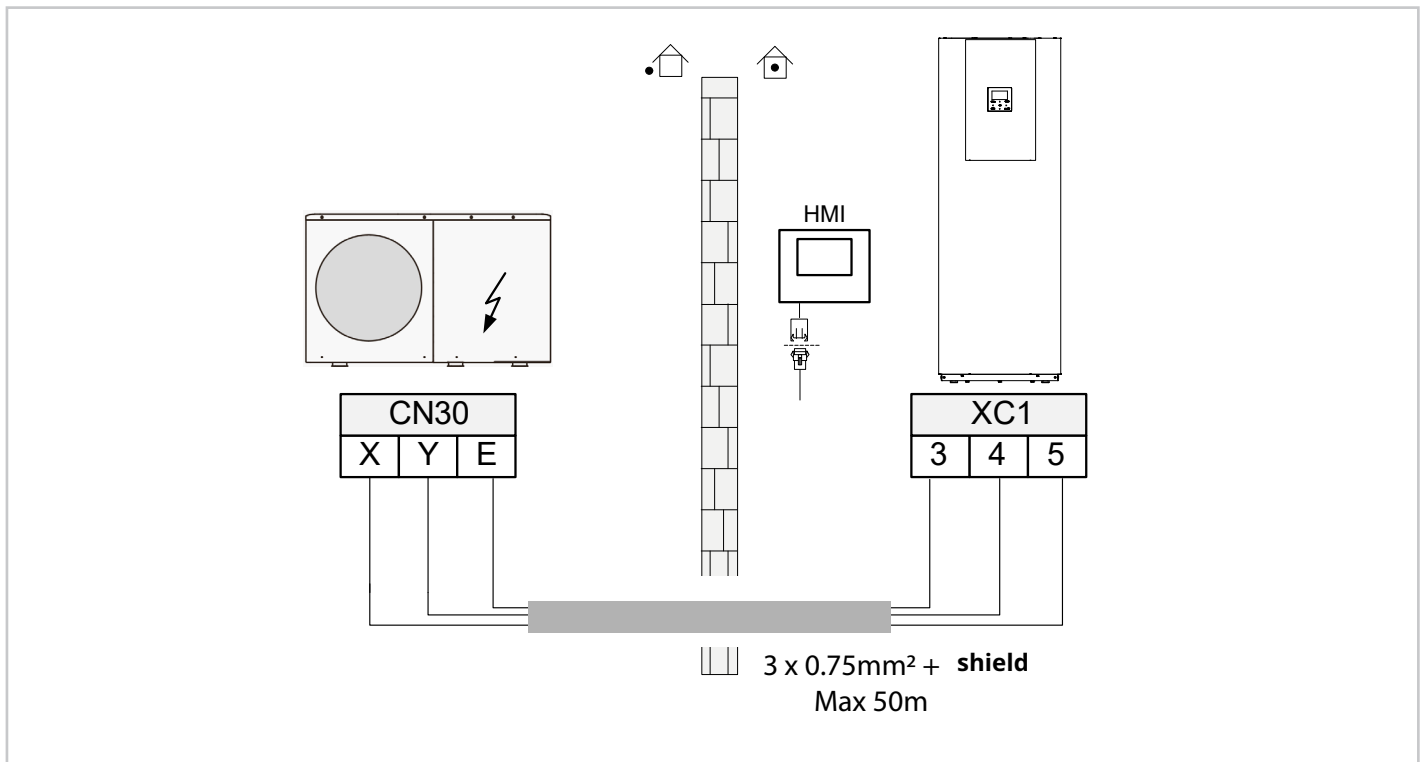

Electrical connections

i External electrical components KM..., Fuses, etc. are to be provided by the customer.

⚠ Connect as shown in the wiring diagrams.

7.5.1 1-zone system

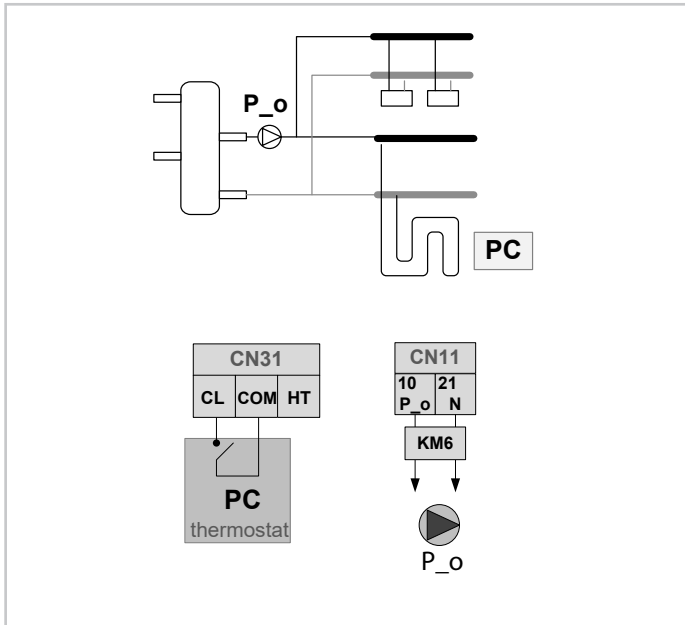

7.5.3 DHW recirculation pump

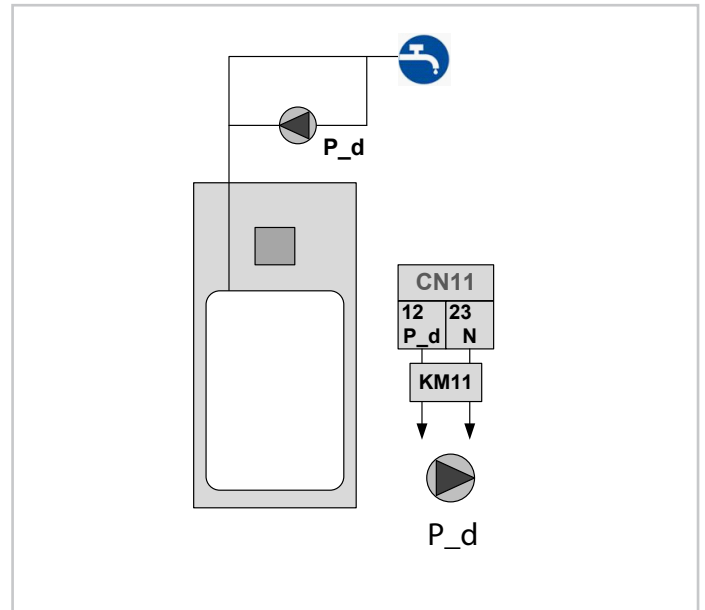

| Contact type | 220-240 VAC |
|--|-------------|
| Maximum tripping of protections (A) | 0.2 |
| Cable cross-section (mm ²) | 0.75 |

7.5.2 Double zone mixed system

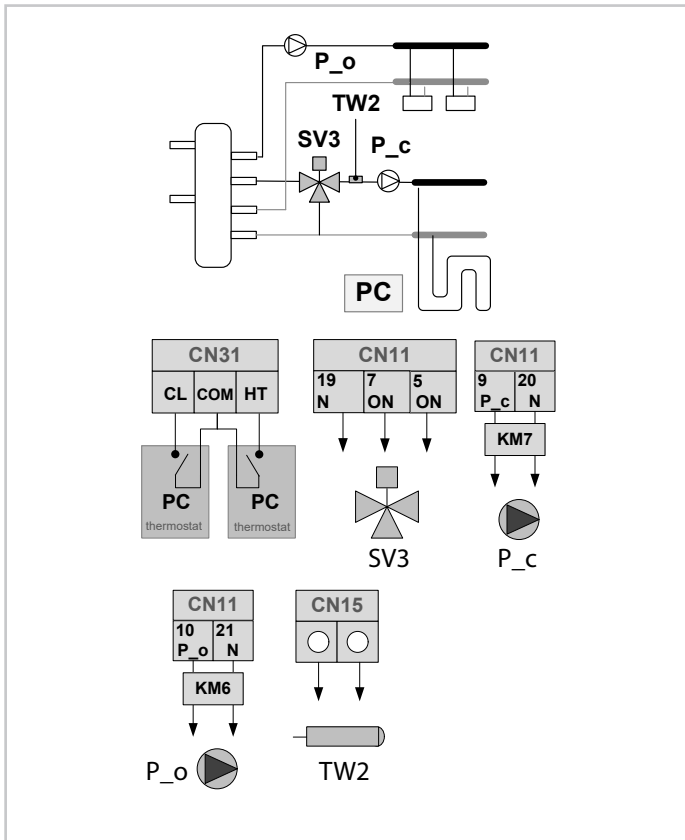

7.5.4 Remote unit on/off

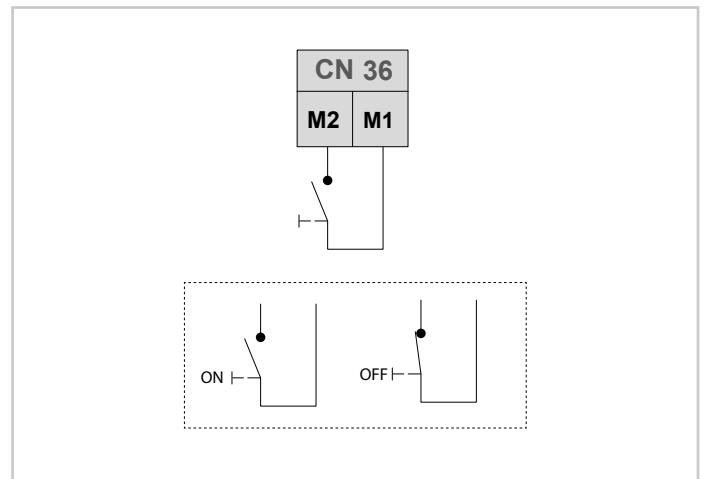

| Contact type | 220-240 VAC |
|--|-------------|
| Maximum tripping of protections (A) | 0.2 |
| Cable cross-section (mm ²) | 0.75 |

7.5.5 Solar pump

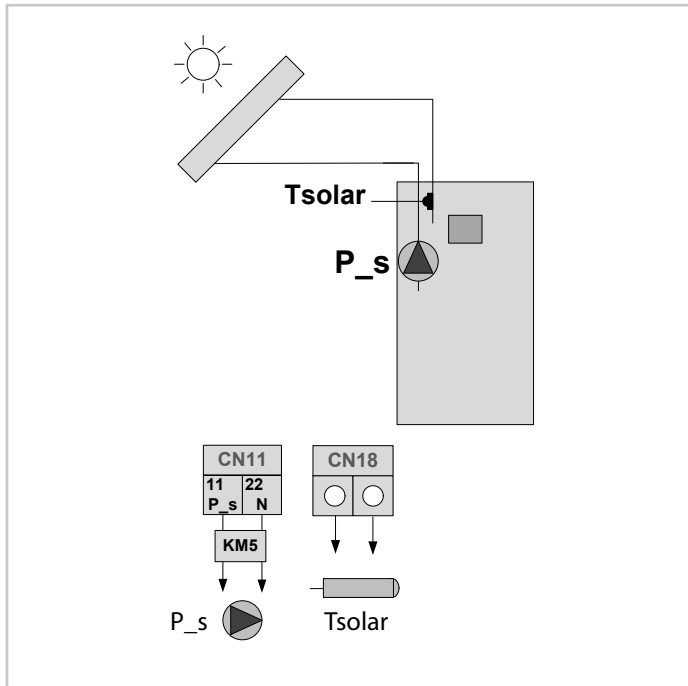



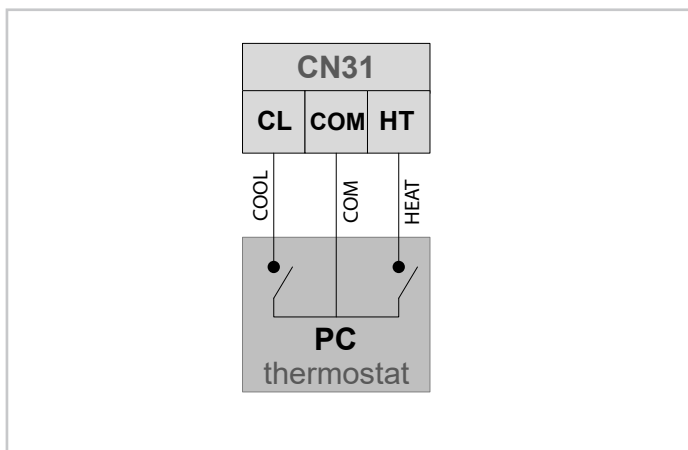

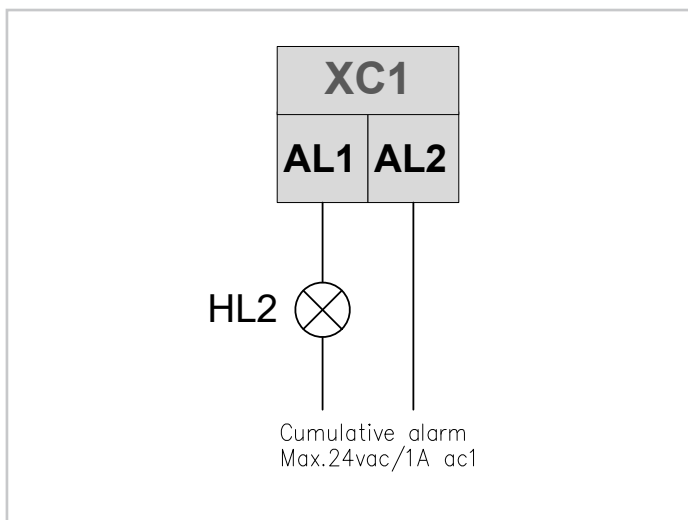

7.5.6 Remote environment thermostat



7.5.7 Alarm signal



8. Starting up the system

-  This section is intended only for the Technical Support Service.
-  The electrical and hydraulic connections and other works typical of the system are the responsibility of the Installer.
-  Operate in compliance with safety regulations in force.
-  Upon request, the service centres performing the start-up.
-  Agree upon in advance the start-up data with the service centre.
-  When installing or servicing, never leave the unit unattended after removing the service panels.
-  **Check that:**
 - the unit should be installed properly and in conformity with this manual
 - the electrical power supply line should be isolated at the beginning
 - the unit isolator is open, locked and equipped with the suitable warning
 - make sure no tension is present

Remember that:

- during installation, unit settings and parameters should be configured by the Installer according to the installation configuration, climatic conditions, and end-user preferences
 - related settings are accessible and programmable through the user interface
-  Refer to the user interface manual for operation.

8.1 Preliminary checks

 For details refer to the different manual sections.

8.1.7.1 Unit power supply: OFF

| | |
|----|---|
| 1 | Clearances: <ul style="list-style-type: none"> • check that distances are observed |
| 2 | Water characteristics: <ul style="list-style-type: none"> • check that the allowable water values are respected |
| 3 | Water filter: <ul style="list-style-type: none"> • check that it is correctly installed at the entrance to the aqueduct |
| 4 | Water line input: <ul style="list-style-type: none"> • check the correct connection of the water outlet and water inlet |
| 5 | Non-return valve: <ul style="list-style-type: none"> • check that there is a non return valve on the DHW circulation |
| 6 | DHW expansion vessel: <ul style="list-style-type: none"> • check that the expansion tank is present |
| 7 | System: <ul style="list-style-type: none"> • check that it is charged • check the system pressure • check that it has been vented |
| 8 | On-site wiring: <ul style="list-style-type: none"> • check that all wiring connections comply with the instructions in this manual |
| 9 | Fuses, circuit breakers or protection devices: <ul style="list-style-type: none"> • check that the size and type comply with the instructions in this manual • ensure that no fuses or protective devices have been bypassed |
| 10 | Automatic switch of integrative electric heater: <ul style="list-style-type: none"> • check that the circuit breaker of the additional electric heater in the electrical panel is closed (varies depending on the type of additional electric heater). Refer to the wiring diagram |
| 11 | Automatic switch of supplementary electric heater for DHW cylinder: <ul style="list-style-type: none"> • check the circuit breaker of the supplementary electric resistance for DHW tank is closed (applicable only to units with optional domestic hot water tank) |
| 12 | Internal wiring: <ul style="list-style-type: none"> • check that the wiring and connections inside the electrical cabinet are tight and in good condition • check that the grounding wiring is perfectly tightened and in good condition |
| 13 | Assembly: <ul style="list-style-type: none"> • check that hydraulic connections are properly tightened to avoid water leaks, abnormal noises and vibrations when starting the unit |
| 14 | Damaged components: <ul style="list-style-type: none"> • check the components and circuitry inside the unit for damage or deformation |
| 15 | Power supply voltage: <ul style="list-style-type: none"> • check that the power supply voltage is within the values indicated on the unit's serial number label |

| | |
|----|---|
| 16 | Shut-off valve: <ul style="list-style-type: none">• check that all shut-off valves are open |
| 17 | Structure: <ul style="list-style-type: none">• check all the structure of the unit is mounted correctly |

8.1.7.2 Outdoor unit settings

⚠ The dip-switches on the outdoor unit must be switched as shown in the figure to enable correct communication between the indoor and outdoor units.

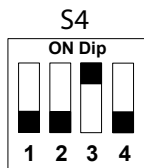

R-32

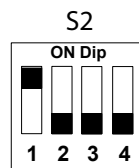

R-290



8.1.7.3 Unit Power: ON

| | |
|---|--|
| 1 | <p>When the unit is turned on, nothing is displayed on the user interface. Check the following anomalies before diagnosing possible error codes:</p> <ul style="list-style-type: none"> • electrical connection problem (power supply or communication signal) • fuse failure on main electronic board |
| 2 | <p>Error code "E8" or "E0" is displayed on the user interface:</p> <ul style="list-style-type: none"> • there is air in the system • water pressure in the system is insufficient • the water flow rate in the system is insufficient <p> Before starting the operation test, make sure the water system and the water tank are filled with water and the air has been vented. Failure to do so could result in irreversible damage to main system components</p> |
| 3 | <p>Error code "EL" is displayed on the user interface:</p> <ul style="list-style-type: none"> • check the wiring between the user interface and the outdoor unit |
| 4 | <p>Initial start-up at low outside temperature:</p> <ul style="list-style-type: none"> • for the initial start-up when the outside temperature is low, the water should be heated gradually • use the underfloor preheating function <p> Refer to the user interface manual for operation.</p> <p>For radiant panel systems</p> <p> If the temperature rises abruptly in a short time, the floor could suffer irreversible damage.</p> |

8.2 SYSTEM CONFIGURATION

 For system configuration, of advanced features, refer to the user interface manual.

9. Maintenance

9.1 Prerequisites

 This section is intended only for the Technical Support Service.

 All operations must be carried out by personnel who meet the requirements of current regulations and are trained in the risks related to such operations.

 Operate in compliance with safety regulations in force.

The maintenance allows to:

- maintaining the unit efficient
- reduce the deterioration speed all the equipment is subject to over time
- collect information and data to understand the efficiency state of the unit and prevent possible faults

Check that:

- the electrical power supply line should be isolated at the beginning
- the unit isolator is open, locked and equipped with the suitable warning
- make sure no tension is present

 After turning off the power, wait at least 5 minutes before accessing to the electrical panel or any other electrical component.

 Before accessing check with a multimeter that there are no residual stresses.

 When installing or servicing, never leave the unit unattended after removing the service panels.

9.2 Maintenance check list

| Intervention frequency (months) | | 1 | 6 | 12 |
|---------------------------------|--|---|---|----|
| 1 | presence of corrosions | | | X |
| 2 | panel fixing | | | X |
| 3 | water filter cleaning | | X | |
| 4 | dirt separator cleaning | | | X |
| 5 | expansion tank | | | X |
| 6 | hydraulic system filling pressure | | X | |
| 7 | water: quality, pH, glycol concentration | | X | |
| 8 | air in the piping | | | X |
| 9 | drain dirt separator | X | X | X |
| 10 | check solar panel fittings for leaks | | X | |
| 11 | check of the fixing and the insulation of the power lead | | | X |
| 12 | check of the earthing cable | | | X |
| 13 | electric panel cleaning | | | X |
| 14 | power remote controls status | | | X |
| 15 | clamp closure, cable isolation integrity | | | X |
| 16 | voltage and phase unbalancing (no load and on-load) | | | X |
| 17 | absorptions of the single electrical loads | | X | |
| 18 | electronic anode | | X | |
| 19 | leak control * | | X | |
| 20 | control device test: alarm signal, thermometers, probes, pressure gauges, etc. | | X | |
| 21 | check schedulers, setpoints, compensations, etc. | | X | |
| 22 | fill in the unit's booklet | | | |

i *Refer to the local regulations. Companies and technicians that carry out installation, maintenance/fixing, leak control and recovery interventions must be CERTIFIED as required by local regulations.

9.3 Unit booklet

It's advisable to create a unit booklet to take notes of the unit interventions.

In this way it will be easier to adequately note the various interventions and aid any troubleshooting.

Report on the booklet:

- date
- intervention description
- carried out measures etc.

9.4 Standby mode

In case of a long period of inactivity:

- ▶ turn off the power
- ▶ avoid the risk of frost (use glycol or empty the system)

9.5 Emptying the system

The units are not fitted with a drain valve, so one must be provided on a pipe connecting to the system near to the device and below it.

 All operations must be carried out with the unit shut down and disconnected from the mains power supply.

Before emptying:

- ▶ check that the system water filling/refilling valve is closed

To drain the system:

- ▶ open the drain valve on the outside of the device
- ▶ open all of the system and terminal relief valves

9.6 Cleaning the outer coating

To clean:

- ▶ soapy water
- ▶ water-based detergents containing anionic and/or non-ionic surfactants

Always rinse with clean water.

 Do not use solvent-based degreasing agents such as: acetone, denatured ethyl alcohol, trichloroethylene, white spirit, etc.

 Do not use dilute acids in aqueous solution (Hydrochloric Acid, Nitric Acid) and products containing dilute acids.

 Do not use dilute bases in aqueous solution (Caustic Soda, Sodium Hypochlorite, Ammonia).

 Do not use fluorinated hydrocarbons.

 Do not use mineral-based lubricating oils.

 These substances can attack the surface of the product and lead to the formation of cracks and, over time, to the

possibility of breakage of the plastic material.

9.7 Water pressure

- ▶ check that the water pressure is greater than 1 bar

If necessary:

- ▶ add water up to 1.5-1.8 bar

9.8 Water filter

- ▶ check and clean the water filter

In case of obstruction:

- ▶ clean the filter

9.9 Expansion vessel

- ▶ check the expansion vessel charge
- ▶ check at least once a year

If you necessary load with nitrogen, take care that the pressure does not exceed the value indicated on the label.

9.10 Unit electrical panel

- ▶ visually inspect the electrical panel
- ▶ check the tightness of the connections
- ▶ check the cleanliness of the electrical panel

9.11 Using glycol

least once a year

- ▶ check the glycol concentration and pH value of the system

A pH value below 8.0:

- ▶ indicates that a significant proportion of the inhibitor has been consumed
- ▶ topping up

A pH value of less than 7.0:

- ▶ indicates that the glycol has oxidised
- ▶ drain and flush the system thoroughly to prevent serious damage

 The glycol solution must be disposed of in accordance with the local laws and regulations in force.

9.12 Magnetic sludge

Magnetic filter separates the impurities (sand particles, rust ... etc) present in the system water.

The impurities are collected in a settling chamber.

Cleaning the filter can also be done with a working system.

Clean the filter:

- during the start up of the unit
- after one week from the start up
- after one month from start up
- once a year

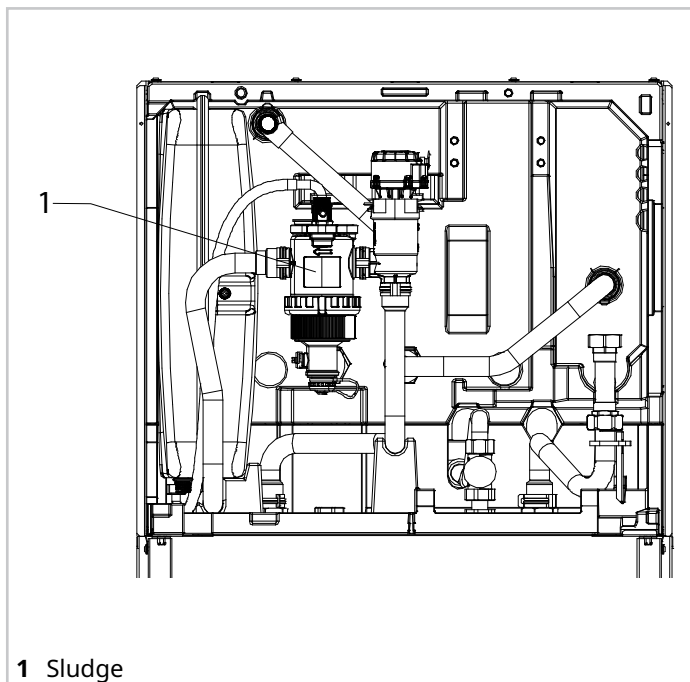

Clean the filter:

- ▶ remove the magnetic ring
- ▶ open the tap to purge impurities
- ▶ close the tap

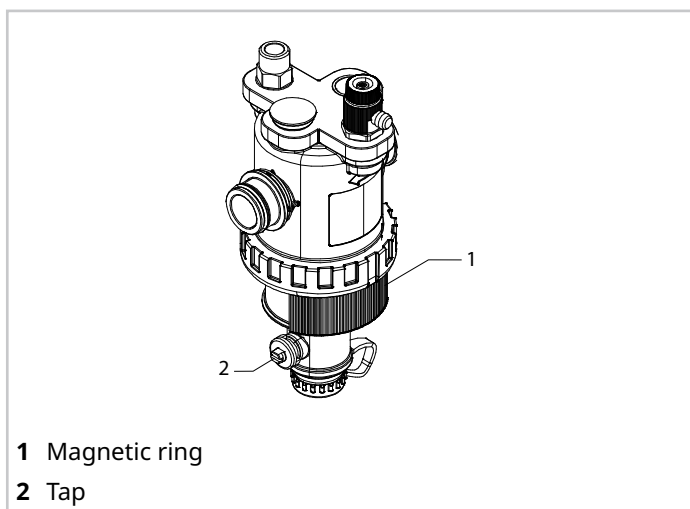

Cleaning (extraordinary)

Close the shut-off valves of the system and water supply.

Disassembly sequence:

- ▶ unscrew the ring nut of the lower cover of the dirt separator
- ▶ remove the filter
- ▶ clean the filter
- ▶ clean the filter and the bottom cover
- ▶ close the bottom cover of the dirt separator
- ▶ open the shut-off valves of the plant and aqueduct

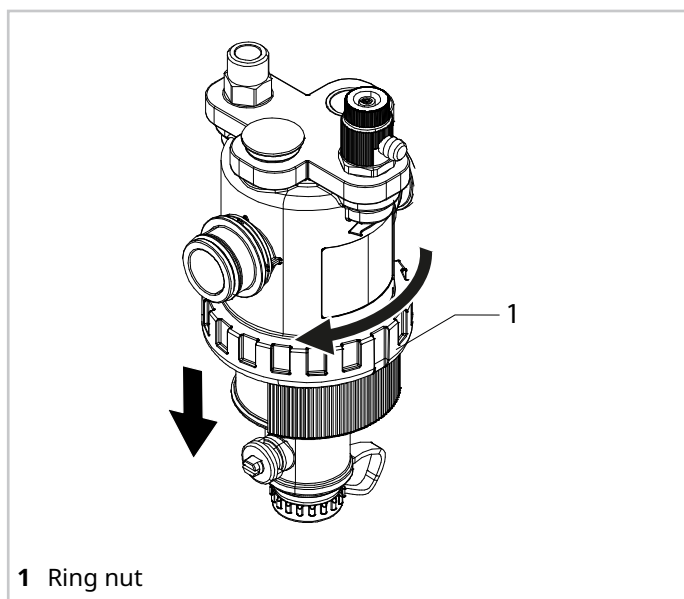

 Check pressure of the plant.

9.13 Safety valve

Almost all losses are caused by impurities deposited inside the valve.

- ▶ check the safety valve for leakage
- ▶ check that the pressure relief valve pipe is correctly positioned for draining the water
- ▶ check that the safety valve pipe is free from obstruction

To carry out a wash:

- ▶ manually open the valve
- ▶ rotate the knob in the sense indicated by the arrow in the knob

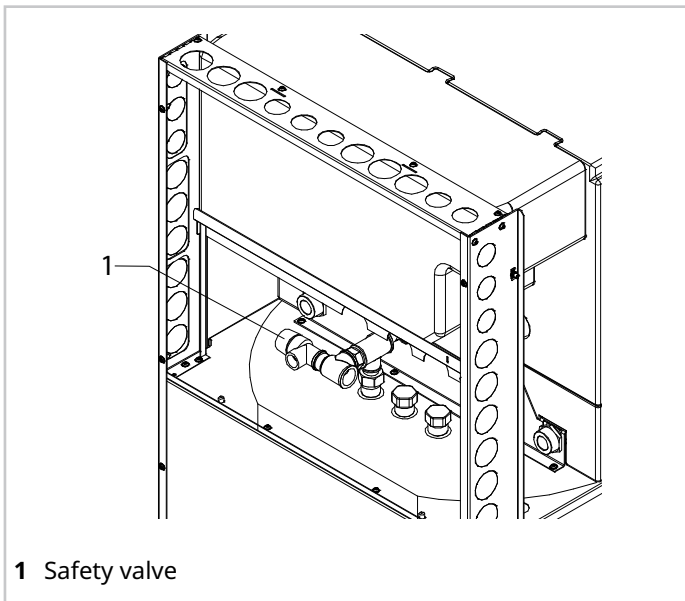

- ⚠ Pay attention to possible scalding from the hot water coming out of the valve.
- ⚠ It's normal if some water drops from the hole of safety valve during operation.
- ⚠ But, if there is a great amount of water, call your service agent for instructions.

9.14 Electronic anode

The unit is equipped with a dynamic system for the tank active protection from corrosion.
The anode is in active titanium.
Periodical substitutions are not foreseen.

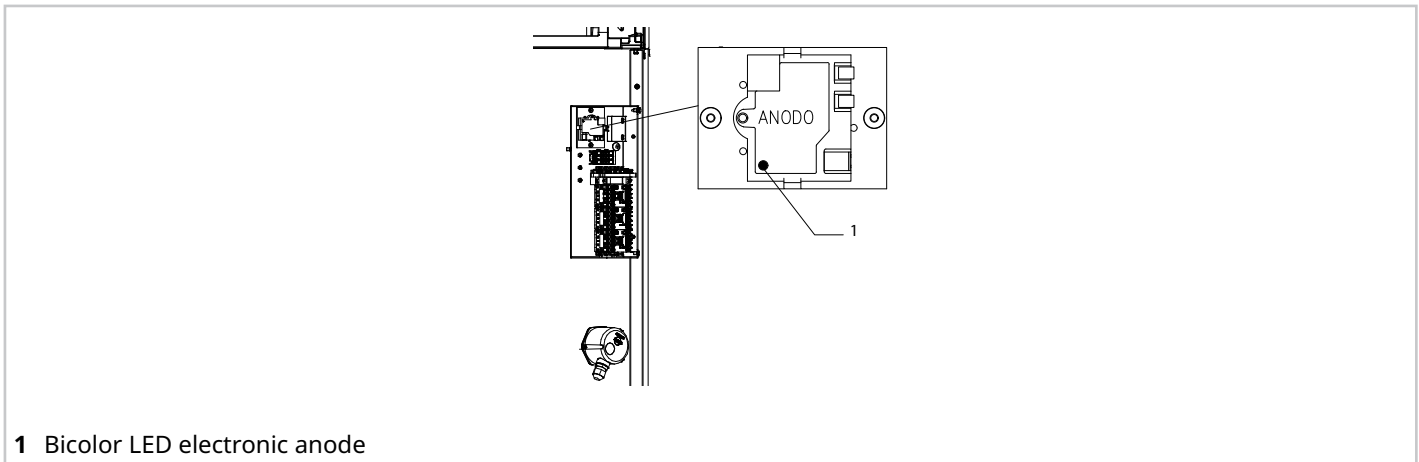

1 Bicolor LED electronic anode

Diagnostics

| | |
|--|---|
| | 3 Rapid red flashes = entry in the signalling function |
| | Number of read flashes shows number of months |
| | Number of green flashes shows numbers of years |
| | 3 Rapid green flashes = exit of the signalling function |

Note: to check the working time during normal operation simply disconnect and reconnect the power supply of the device. This is locked and not manageable.

Power supply alarm signals

| | |
|--|---|
| | 1 Red flash every 1 second - Insufficient power supply (<11V) |
| | 2 Red flashes every 1 second - Overvoltage from power supply (>14V) |
| | No signal - Device off - No power supply |

Power supply alarm signals

| | |
|--|---|
| | Green flash then one long red, alternate - Anode disconnected |
| | 3 Red flashes every 1 second - Short circuit on output |
| | 2 Red flashes every 1 second - Overvoltage from power supply (>14V) |

Working signals

| | |
|--|--|
| | 1 Green flash every 1 second, repeat - Protection OK (*) |
| | 1 Green flash + 1 red, repeat - Protection low (*) |
| | 1 Green flash + 2 red, repeat - No protection (*) |
| | 1 Green flash + 3 red, repeat - Over Protection (*) |

(*) At first use, it may be possible to have all these signals at the same time as the wall potential could be close to the protection limit.

Signal priority - In case of simultaneous signals

| | |
|-----------------|---------------------|
| High priority | Power supply alarms |
| Medium priority | Wiring alarms |
| Low priority | Working alarms |

10. Decommissioning

10.1 Disconnection

 Awaiting decommissioning and disposal, the unit can also be stored outdoors, as bad weather and rapid changes in temperature do not harm the environment provided that the electric, cooling and hydraulic circuits of the unit are intact and closed.



10.1.1 WEEE INFORMATION

The manufacturer is registered on the EEE National Register, in compliance with implementation of Directive 2012/19/ EU and relevant national regulations on waste electrical and electronic equipment.

This Directive requires electrical and electronic equipment to be disposed of properly.

Equipment bearing the crossed-out wheeled bin mark must be disposed of separately at the end of its life cycle to prevent damage to human health and to the environment.

Electrical and electronic equipment must be disposed of together with all of its parts.

To dispose of "household" electrical and electronic equipment, the manufacturer recommends you contact an authorised dealer or an authorised ecological area.

"Professional" electrical and electronic equipment must be disposed of by authorised personnel through established waste disposal authorities around the country.

In this regard, here is the definition of household WEEE and professional WEEE:

WEEE from private households: WEEE originating from private households and WEEE which comes from commercial, industrial, institutional and other sources which, because of its nature and quantity, is similar to that from private households. Subject to the nature and quantity, where the waste from EEE was likely to have been by both a private household and users of other than private households, it will be classed as private household WEEE;

Professional WEEE: all WEEE which comes from users other than private households.

This equipment may contain:

- refrigerant gas, the entire contents of which must be recovered in suitable containers by specialised personnel with the necessary qualifications;
- lubrication oil contained in compressors and in the cooling circuit to be collected;
- mixtures with antifreeze in the water circuit, the contents of which are to be collected;
- mechanical and electrical parts to be separated and disposed of as authorised.

When machine components to be replaced for maintenance purposes are removed or when the entire unit reaches the end of its life and needs to be removed from the installation, waste should be separated by its nature and disposed of by authorised personnel at existing collection centres.

10.2 Residual risks

Refer to the outdoor unit manual.

11. Technical data

Construction characteristics - Indoor unit

| SIZE | | | A - 190 L | B - 250 L |
|---------------------------------|---|----------------|---------------------|---------------------|
| System characteristics | | | | |
| Maximum system circuit pressure | | bar | 3 | 3 |
| System expansion tank | 1 | l | 12 | 12 |
| Expansion tank pre-charge | | bar | 1 | 1 |
| System water connections | | inch | 1" | 1" |
| DHW Characteristics | | | | |
| Type of Tank | | - | Acciaio Vetrificato | Acciaio Vetrificato |
| Domestic hot water Tank Volume | | l | 190 | 250 |
| Internal coil exchange surface | | m ² | 1,7 | 1,7 |
| Water tank leakage | | W/K | 1.81(1.95) | 2.04(2.20) |
| DHW safety electric heater | | kW | 2 | 2 |
| Maximum DHW circuit pressure | | bar | 6 | 6 |
| DHW expansion tank | 2 | l | 12 | 16 |
| DHW water connections | | inch | 3/4" | 3/4" |
| Dimensions | | | | |
| Operation (L x W x H) | | mm | 600 x 615 x 1685 | 600 x 615 x 1995 |
| Packaging (L x W x H) | | mm | 660 x 690 x 1890 | 660 x 690 x 2190 |
| Operation weight | | kg | 357 | 180 |
| Shipping weight | | kg | 205 | 445 |

1. Sufficient volume up to a maximum of 60 litres of water content in the system
2. It is mandatory for the installer to install the DHW expansion valve. The volumes indicated are for reference purposes only.

Hydraulic data - Indoor unit + Outdoor unit - R-32

| SIZE | Characteristics | 2.1 | | 3.1 | | 4.1 | | 5.1 | | 6.1 | | 7.1 | | 8.1 | |
|------|-----------------------------------|-------|-------|-------|-------|-------|-------|-------|-------|-------|-------|-------|-------|-------|--|
| | | 190 L | 250 L | 190 L | 250 L | 190 L | 250 L | 190 L | 250 L | 250 L | 250 L | 250 L | 250 L | 250 L | |
| | Minimum system water content | l | 30 | 30 | 70 | 70 | 70 | 70 | 70 | 70 | 70 | 70 | 70 | 70 | |
| | Minimum water flow rate allowed | l/s | 0,11 | 0,11 | 0,11 | 0,11 | 0,11 | 0,11 | 0,2 | 0,2 | 0,2 | 0,2 | 0,2 | | |
| | Maximum water flow rate allowed | l/s | 0,25 | 0,35 | 0,46 | 0,58 | 0,69 | 0,76 | 0,83 | | | | | | |
| | Net boiler capacity | l | 182 | 240 | 182 | 240 | 182 | 240 | 182 | 240 | 240 | 240 | 240 | | |
| | DHW tank setpoint | °C | 50 | 50 | 50 | 50 | 50 | 50 | 50 | 50 | 50 | 50 | 50 | | |
| | Water mixed at 40°C (V40) | l | 204 | 269 | 204 | 269 | 204 | 269 | 204 | 269 | 269 | 269 | 269 | | |
| | Heating time | h:min | 02:30 | 02:25 | 02:30 | 02:25 | 02:08 | 02:25 | 02:08 | 02:05 | 01:46 | 01:46 | 01:46 | | |
| | Energy consumption during heating | kWh | 2,20 | 2,70 | 2,20 | 2,70 | 2,30 | 2,85 | 2,30 | 2,85 | 3,01 | 3,01 | 3,01 | | |

1. Consider the water content of the area with less volume
2. Time required to bring the water volume of the tank from a temperature of 10°C to a temperature of 50°C
3. Energy consumption to bring the water volume of the tank from a temperature of 10°C to a temperature of 50°C

Hydraulic data - Indoor unit + Outdoor unit - R-290

| SIZE | Characteristics | 2.1 | | 3.1 | | 4.1 | | 5.1 | | 6.1 | | 7.1 | | 8.1 | |
|------|-----------------------------------|-------|-------|-------|-------|-------|-------|-------|-------|-------|-------|-------|-------|-------|--|
| | | 190 L | 250 L | 190 L | 250 L | 190 L | 250 L | 190 L | 250 L | 250 L | 250 L | 250 L | 250 L | 250 L | |
| | Minimum system water content | l | 40 | 40 | 70 | 70 | 70 | 70 | 70 | 70 | 70 | 70 | 70 | | |
| | Minimum water flow rate allowed | l/s | 0,1 | 0,1 | 0,17 | 0,17 | 0,17 | 0,17 | 0,17 | 0,17 | 0,17 | 0,17 | 0,17 | | |
| | Maximum water flow rate allowed | l/s | 0,42 | 0,42 | 0,64 | 0,69 | 0,89 | 1 | 1,08 | | | | | | |
| | Net boiler capacity | l | 182 | 240 | 182 | 240 | 182 | 240 | 182 | 240 | 240 | 240 | 240 | | |
| | DHW tank setpoint | °C | 50 | 50 | 50 | 50 | 50 | 50 | 50 | 50 | 50 | 50 | 50 | | |
| | Water mixed at 40°C (V40) | l | 204 | 269 | 204 | 269 | 204 | 269 | 204 | 269 | 269 | 269 | 269 | | |
| | Heating time | h:min | 01:57 | 01:52 | 01:57 | 01:52 | 01:35 | 01:30 | 01:35 | 01:30 | 01:15 | 01:15 | 01:15 | | |
| | Energy consumption during heating | kWh | 2,40 | 2,95 | 2,40 | 2,95 | 2,50 | 3,05 | 2,50 | 3,05 | 3,25 | 3,25 | 3,25 | | |

1. Consider the water content of the area with less volume
2. Time required to bring the water volume of the tank from a temperature of 10°C to a temperature of 50°C
3. Energy consumption to bring the water volume of the tank from a temperature of 10°C to a temperature of 50°C

EASYTower unit 190 L

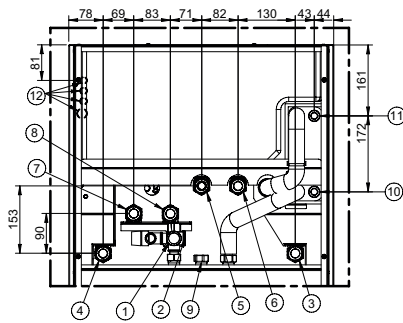

DETTAGLIO B

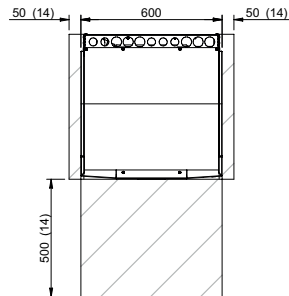
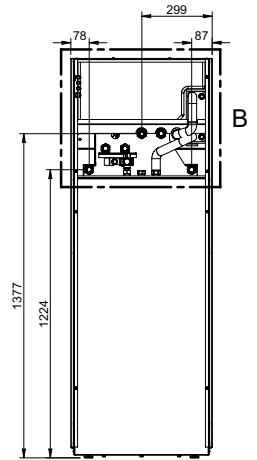
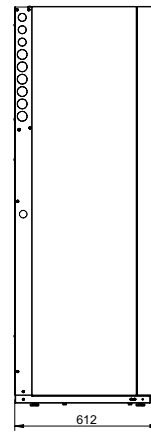
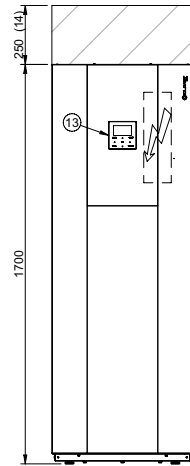

1. Domestic hot water outlet M 3/4"
2. Water supply system inlet M 3/4"
3. Return to outdoor unit M 1"
4. Supply from outdoor unit M 1"
5. Return from user side system M 1* area 1
6. Supply to user side system M 1* area 1 (optional accessory)
7. Return from user side system M 1* area 2 (optional accessory)
8. Supply to user side system M 1* area 2 (optional accessory)
9. DHW circulation circuit inlet M 3/4"
10. Return from solar system M 3/4"
11. Supply to solar system M 3/4"
12. Power input
13. Unit control keypad
14. Functional spaces for standard unit

| SIZE | | 190 L |
|------------------|----|-------|
| Operation weight | kg | 357 |
| Shipping weight | kg | 158 |

The presence of optional accessories may result in significant variation of the weights indicated.

EASYTower unit 250 L

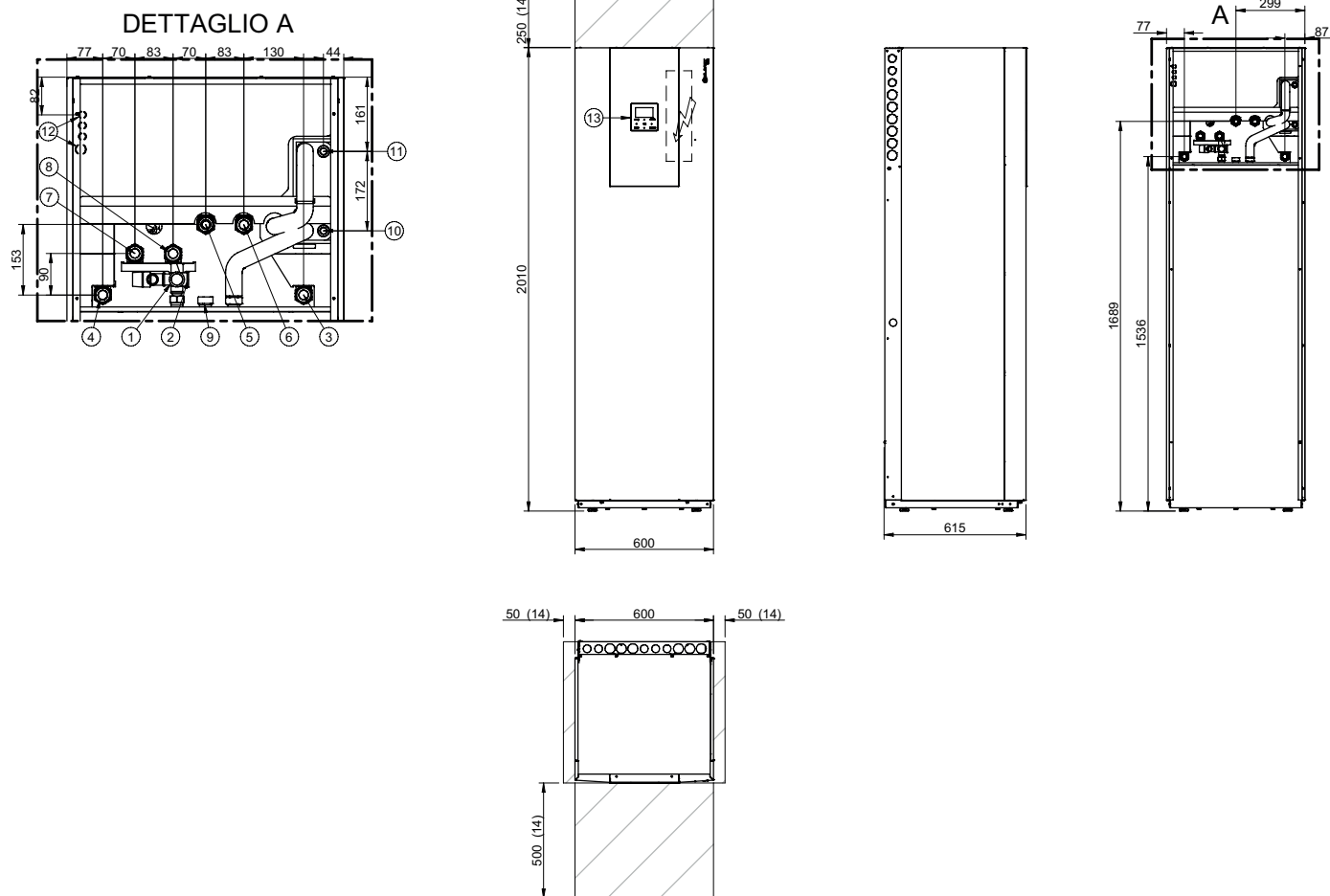

1. Domestic hot water outlet M 3/4"
2. Water supply system inlet M 3/4"
3. Return to outdoor unit M 1"
4. Supply from outdoor unit M 1"
5. Return from user side system M 1* area 1
6. Supply to user side system M 1* area 1 (optional accessory)
7. Return from user side system M 1* area 2 (optional accessory)
8. Supply to user side system M 1* area 2 (optional accessory)
9. DHW circulation circuit inlet M 3/4"
10. Return from solar system M 3/4"
11. Supply to solar system M 3/4"
12. Power input
13. Unit control keypad
14. Functional spaces for standard unit

| SIZE | | 250 L |
|------------------|----|-------|
| Operation weight | kg | 417 |
| Shipping weight | kg | 175 |

The presence of optional accessories may result in significant variation of the weights indicated.

FOR OVER 35 YEARS, WE HAVE BEEN OFFERING
SOLUTIONS TO ENSURE SUSTAINABLE
COMFORT AND THE WELL-BEING OF PEOPLE
AND THE ENVIRONMENT



Info & Contacts: www.clivet.com

