

*Indoor unit with DHW tank for
Hydro-Split heat pumps*

EASYMINI HQCN-NEE 1 MC RANGE



TECHNICAL BULLETIN



DHW TANK

50 L

Page

3	Features and benefits
4	Standard unit technical specifications
5	Option compatibility
6	General technical data
11	Hydraulic connections
12	System connections
13	Dimensional drawings

Features and benefits

EASYModules are specialized autonomous heat pump systems dedicated to meet the thermal and comfort requirements of single or multi-family homes with medium-low energy consumption. The system consists of a new generation monobloc outdoor unit, EDGE EVO 2.0 to R-32 and EDGE F to R-290, with very high efficiency that encloses the refrigerant circuit inside, this is combined with an internal hydraulic module available in four different versions as shown below.

EASYMINI

- Mini Version
- 50-litre domestic water tank
- Single-area water booster kit already included in standard unit
- Built-in WiFi for connection to the dedicated APP
- Compact dimensions, suitable for replacing a boiler



EASYTANK

- Tower Version
- Two domestic water volumes 190 and 250 litres
- Built-in WiFi for connection to the dedicated APP

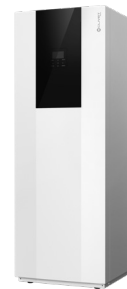

EASYBOX

- Box Version
- Integrated three-way valve for domestic hot water
- Compact dimensions
- Built-in WiFi for connection to the dedicated APP



EASYIN

- Uncased version
- 150-litre domestic water tank can be expanded to 300 litres
- Compact dimensions for easy installation in walls
- Also available in the hybrid version with 24 kW or 34 kW boiler
- Built-in WiFi for connection to the dedicated APP



Outdoor units that can be combined:

Packaged heat pumps with hermetic Twin Rotary DC compressor with soft start, controlled by an inverter that constantly modulates the power delivered according to actual demand, guaranteeing the best in terms of reliability, low consumption and high seasonal efficiency.

EDGE EVO 2.0 - WISAN-YME 1 S

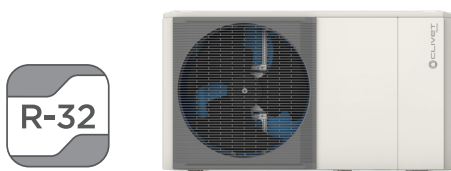

EDGE F - WISAN-PME 1 S

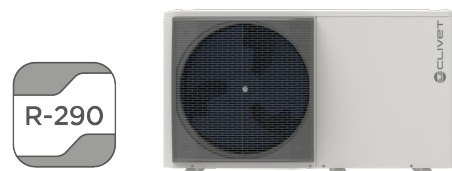

EASYMini - Indoor unit

Zinc magnesium structure

Supporting structure made of zinc-magnesium sheet metal that ensures excellent mechanical features and high long-term resistance to corrosion.

Panelling

External panelling in zinc-magnesium sheet metal, with white paint in RAL 9003 to ensure better resistance to corrosion. Panels that can be easily removed to allow full access to internal components.

Domestic hot water

- 50-litre domestic water storage tank, in stainless steel and outer insulation in polyurethane (50 mm thick).
- Electronic anode
- 2 kW safety and antilegionella cycle electric heater
- Technical water - domestic hot water plate exchanger
- Water tank drain tap

Water circuit

- 3-litre DHW side expansion tank
- Safety flow switch for water flow
- 3-way switching valve for system or domestic water
- Magnetic dirt separator
- 8-litre expansion tank
- Anti-scalding valve
- Pressure relief valve 6 bar
- Single-area water booster kit
- 15-litre inertial tank

Electrical panel

The electrical panel is located inside the unit and can be accessed by an easily removable panel.

The power section includes:

- power inlet terminals.

Coloured keypad for:

- BMS management;
- daily and weekly switch-on/off scheduler and set point;
- anti-legionella function scheduling;
- one-area booster management;
- solar thermal management;
- management for backup heaters;
- interface terminal with remotely controlled graphic display
- integrated wifi module for connection to the APP
- cascade operation;

Standard unit kit

- Torx insert for opening and closing the unit's panels
- Cover cap for remotely controlled keypad
- 1 quick coupling spring
- 1 expansion tank connection gasket
- 1 O-ring



Option compatibility

Compatibility of options for EASYMINI + EDGE Hydro-Split system.

When combining EASYMINI and EDGE units, the following options can be selected for the packaged unit:

“Hybrid configuration” section

- GAS BOILER_UC / GAS BOILER_FE 24.4-33.4 - 4-pipe condensing boiler for hybrid heat pumps
- KCSAFX - \varnothing 60/100 mm vertical coaxial fitting
- CCOAX - 90° coaxial elbow for \varnothing 60/100 mm horizontal outlet that can be adjusted at 360°
- TCOAX - L1000mm \varnothing 60/100 coaxial pipe with terminal
- KAS80X - \varnothing 80 mm vertical fittings
- KSDFX - \varnothing 80 mm flue gas splitter kit
- VDACSX - Thermostatic switching valve for domestic water
- GAS BOILER_UC 70.2-115.2-200F.2 - 2-pipe condensing boiler for hybrid heat pumps
- INAILX - INAIL safety kit for installation of single boiler
- FH100X - \varnothing 100mm vertical smoke discharge terminal
- HIDUCX - Remote control for UC 70.2-115.2 boilers

“Other accessories supplied separately” section

- KTFLX - Hose kit for connection to the unit
- VAGX - Safety antifreeze valve for system
- DTX - Drain pan with electric heater
- AMRX - Kit of antivibration mounts for floor installation
- AMMSX - Kit of anti-seismic antivibration mounts for floor installation
- ASTFX - Kit of antivibration mounts for installation on wall brackets, inertial storage tank or tray
- KSIPX - Wall fixing bracket kit
- HTC2WX - White HID-TConnect 2 chronothermostat for temperature control
- CONTROL4NRG

Construction characteristics - Indoor unit

SIZE		A
System characteristics		
Maximum system pressure	bar	3
System expansion tank	l	8
Expansion tank pre-charging	bar	1
System water connections	inch	1"
Size		
Inertial tank volume	l	15
Operation (L x W x H)	mm	455 x 550 x 1113
Packaging (L x W x H)	mm	1180 x 500 x 708
Operating weight	kg	140
Shipping weight	kg	84

1. Sufficient volume up to a maximum of 60 litres of system water content.

General technical data

EDGE EVO 2.0 - WiSAN-YME 1 S - performance

Heating

SIZE		2.1	3.1	4.1	5.1	6.1 / 6.1T	7.1 / 7.1T	8.1 / 8.1T
Air 7 °C - Water 35 °C								
Rated heating capacity	1 kW	4,20	6,35	8,40	10,0	12,1	14,5	15,9
Total power input	1 kW	0,82	1,28	1,63	2,02	2,44	3,15	3,53
COP	1 -	5,10	4,95	5,15	4,95	4,95	4,60	4,50
Water flow rate	1 l/s	0,20	0,30	0,40	0,48	0,58	0,69	0,76
Nominal available pressure	1 kPa	85	84	80	71	60	48	40
Air 2 °C - Water 35 °C								
Rated heating capacity	2 kW	4,40	5,50	7,10	8,20	9,20	11,0	13,0
Total power input	2 kW	1,10	1,41	1,73	2,05	2,36	3,06	3,77
COP	2 -	4,00	3,90	4,10	4,00	3,90	3,60	3,45
Water flow rate	2 l/s	0,21	0,26	0,34	0,39	0,44	0,53	0,62
Nominal available pressure	2 kPa	85	85	82	80	78	65	54
Air -7 °C - Water 35 °C								
Rated heating capacity	3 kW	4,70	6,00	7,00	8,00	10,0	12,0	13,1
Total power input	3 kW	1,52	2,00	2,19	2,62	3,33	4,21	4,85
COP	3 -	3,10	3,00	3,20	3,05	3,00	2,85	2,70
Water flow rate	3 l/s	0,22	0,29	0,33	0,38	0,48	0,57	0,63
Nominal available pressure	3 kPa	85	85	83	81	72	60	55
Air 7 °C - Water 45 °C								
Rated heating capacity	4 kW	4,30	6,30	8,10	10,0	12,3	14,1	16,0
Total power input	4 kW	1,13	1,70	2,10	2,67	3,32	3,92	4,57
COP	4 -	3,80	3,70	3,85	3,75	3,70	3,60	3,50
Water flow rate	4 l/s	0,21	0,30	0,39	0,48	0,59	0,67	0,76
Nominal available pressure	4 kPa	85	85	80	70	56	48	38
Air 7 °C - Water 55 °C								
Rated heating capacity	5 kW	4,40	6,00	7,50	9,50	11,9	13,8	16,0
Total power input	5 kW	1,49	2,03	2,36	3,06	3,90	4,68	5,61
COP	5 -	2,95	2,95	3,18	3,10	3,05	2,95	2,85
Water flow rate	5 l/s	0,21	0,29	0,36	0,45	0,57	0,66	0,76
Nominal available pressure	5 kPa	85	85	82	75	60	52	38

Data according to EN 14511:2018.

1. entering/leaving water temperature 30/35 °C, outdoor air temperature -7 °C dry bulb / -6 °C wet bulb
2. entering/leaving water temperature 30/35 °C, outdoor air temperature -2 °C dry bulb / -1 °C wet bulb
3. entering/leaving water temperature 30/35 °C, outdoor air temperature -7 °C dry bulb / -8 °C wet bulb
4. entering/leaving water temperature 40/45 °C, outdoor air temperature 7 °C dry bulb / 6 °C wet bulb
5. entering/leaving water temperature 47/55 °C, outdoor air temperature 7 °C dry bulb / 6 °C wet bulb

Cooling

SIZE		2.1	3.1	4.1	5.1	6.1 / 6.1T	7.1 / 7.1T	8.1 / 8.1T
Air 35 °C - Water 18 °C								
Nominal cooling capacity	6 kW	4,50	6,50	8,30	9,90	12,0	13,5	14,2
Total power input	6 kW	0,82	1,35	1,64	2,18	3,04	3,74	3,94
EER	6 -	5,50	4,80	5,05	4,55	3,95	3,61	3,61
Water flow rate	6 l/s	0,22	0,31	0,40	0,47	0,57	0,65	0,68
Nominal available pressure	6 kPa	85	84	80	71	60	54	47
Air 35 °C - Water 7 °C								
Nominal cooling capacity	7 kW	4,70	7,00	7,45	8,20	11,5	12,4	14,0
Total power input	7 kW	1,36	2,33	2,22	2,52	4,18	4,96	5,60
EER	7 -	3,45	3,00	3,35	3,25	2,75	2,50	2,50
Water flow rate	7 l/s	0,22	0,33	0,36	0,39	0,55	0,59	0,67
Nominal available pressure	7 kPa	85	83	82	80	63	56	48

Data according to EN 14511:2018.

6. entering/leaving water temperature 23/18 °C, outdoor air temperature -35 °C dry bulb / -27 °C wet bulb
7. entering/leaving water temperature 12/7 °C, outdoor air temperature -35 °C dry bulb / -27 °C wet bulb

EDGE F - WiSAN-PME 1 S - performance

Heating

SIZE		2.1	3.1	4.1	5.1	6.1 / 6.1T	7.1 / 7.1T	8.1 / 8.1T
Air 7 °C - Water 35 °C								
Rated heating capacity	1 kW	4,50	6,20	8,40	10,0	12,0	14,0	15,0
Total power input	1 kW	0,87	1,27	1,68	2,13	2,50	3,11	3,41
COP	1 -	5,15	4,90	5,00	4,70	4,80	4,50	4,40
Water flow rate	1 l/s	0,21	0,30	0,40	0,48	0,57	0,67	0,71
Nominal available pressure	1 kPa	89	87	80	71	63	54	49
Air 2 °C - Water 35 °C								
Rated heating capacity	2 kW	4,40	5,60	7,10	8,20	9,10	10,1	12,8
Total power input	2 kW	1,07	1,44	1,84	2,25	2,39	2,81	4,00
COP	2 -	4,10	3,90	3,85	3,65	3,80	3,60	3,20
Water flow rate	2 l/s	0,21	0,27	0,34	0,39	0,43	0,48	0,61
Nominal available pressure	2 kPa	89	88	85	80	81	75	60
Air -7 °C - Water 35 °C								
Rated heating capacity	3 kW	4,50	5,90	7,00	8,00	10,0	11,5	12,7
Total power input	3 kW	1,45	2,00	2,33	2,81	3,57	4,00	4,26
COP	3 -	3,10	2,95	3,00	2,85	2,80	2,70	2,50
Water flow rate	3 l/s	0,21	0,28	0,33	0,38	0,48	0,52	0,55
Nominal available pressure	3 kPa	89	88	85	80	75	68	66
Air 7 °C - Water 45 °C								
Rated heating capacity	4 kW	4,50	6,40	8,20	10,0	12,0	14,0	15,0
Total power input	4 kW	1,11	1,68	2,13	2,74	3,24	4,00	4,48
COP	4 -	4,05	3,80	3,85	3,65	3,70	3,50	3,35
Water flow rate	4 l/s	0,21	0,30	0,39	0,48	0,57	0,67	0,71
Nominal available pressure	4 kPa	89	87	80	71	63	54	49
Air 7 °C - Water 55 °C								
Rated heating capacity	5 kW	4,60	6,20	7,80	9,50	12,0	14,0	15,0
Total power input	5 kW	1,44	2,00	2,44	3,11	3,87	4,67	5,26
COP	5 -	3,20	3,10	3,20	3,05	3,10	3,00	2,85
Water flow rate	5 l/s	0,14	0,18	0,23	0,28	0,36	0,42	0,45
Nominal available pressure	5 kPa	90	89	86	85	87	81	78

Data according to EN 14511:2022.

1. entering/leaving water temperature 30/35 °C, outdoor air temperature -7 °C dry bulb / -6 °C wet bulb
2. entering/leaving water temperature 30/35 °C, outdoor air temperature -2 °C dry bulb / -1 °C wet bulb
3. entering/leaving water temperature 30/35 °C, outdoor air temperature -7 °C dry bulb / -8 °C wet bulb
4. entering/leaving water temperature 40/45 °C, outdoor air temperature 7 °C dry bulb / 6 °C wet bulb
5. entering/leaving water temperature 47/55 °C, outdoor air temperature 7 °C dry bulb / 6 °C wet bulb

Cooling

SIZE		2.1	3.1	4.1	5.1	6.1 / 6.1T	7.1 / 7.1T	8.1 / 8.1T
Air 35 °C - Water 18 °C								
Nominal cooling capacity	1 kW	4,50	6,50	8,30	10,0	12,0	14,0	16,0
Total power input	1 kW	0,82	1,27	1,61	2,11	2,67	3,33	4,10
EER	1 -	5,50	5,10	5,15	4,75	4,50	4,20	3,90
Water flow rate	1 l/s	0,21	0,31	0,40	0,48	0,57	0,67	0,76
Nominal available pressure	1 kPa	89	87	80	71	63	54	45
Air 35 °C - Water 7 °C								
Nominal cooling capacity	2 kW	4,70	6,80	7,50	8,90	11,5	12,7	14,0
Total power input	2 kW	1,29	2,19	2,17	2,74	3,77	4,38	5,09
EER	2 -	3,65	3,10	3,45	3,25	3,05	2,90	2,75
Water flow rate	2 l/s	0,22	0,32	0,36	0,42	0,55	0,60	0,67
Nominal available pressure	2 kPa	89	86	83	81	66	60	54

Data according to EN 14511:2022

1. entering/leaving water temperature 23/18 °C, outdoor air temperature -35 °C dry bulb / -27 °C wet bulb
2. entering/leaving water temperature 12/7 °C, outdoor air temperature -35 °C dry bulb / -27 °C wet bulb

General technical data

Hydraulic data - Indoor unit + EDGE EVO 2.0 - WiSAN-YME 1 S

SIZE		2.1	3.1	4.1	5.1	6.1	7.1	8.1
Minimum system water content	l	30	30	70	70	70	70	70
Minimum water flow rate allowed	l/s	0,11	0,11	0,11	0,11	0,2	0,2	0,2
Maximum water flow rate allowed	l/s	0,25	0,35	0,46	0,58	0,69	0,76	0,83
Net boiler capacity	l	50	50	50	50	50	50	50
DHW tank setpoint	°C	50	50	50	50	50	50	50
Water mixed at 40°C (V40)	l	62	62	62	62	62	62	62
Heating time	h:min	00:55	00:55	00:42	00:42	00:36	00:36	00:36
Energy consumption during heating	kWh	0,72	0,72	0,88	0,88	0,96	0,96	0,96



1. Consider the water content of the area with less volume
2. Time required to bring the water volume of the tank from a temperature of 10°C to a temperature of 50°C
3. Energy consumption to bring the water volume of the tank from a temperature of 10°C to a temperature of 50°C

Hydraulic data - Indoor unit + EDGE F - WiSAN-PME 1 S

SIZE		2.1	3.1	4.1	5.1	6.1	7.1	8.1
Minimum system water content	l	30	30	70	70	70	70	70
Minimum water flow rate allowed	l/s	0,10	0,10	0,17	0,17	0,17	0,17	0,17
Maximum water flow rate allowed	l/s	0,42	0,42	0,64	0,69	0,89	1	1,08
Net boiler capacity	l	50	50	50	50	50	50	50
DHW tank setpoint	°C	50	50	50	50	50	50	50
Water mixed at 40°C (V40)	l	62	62	62	62	62	62	62
Heating time	h:min	00:39	00:39	00:29	00:29	00:23	00:23	00:23
Energy consumption during heating	kWh	0,81	0,81	1,00	1,00	1,13	1,13	1,13



4. Consider the water content of the area with less volume
5. Time required to bring the water volume of the tank from a temperature of 10°C to a temperature of 50°C
6. Energy consumption to bring the water volume of the tank from a temperature of 10°C to a temperature of 50°C

Electrical data

Standard EASYMINI indoor unit

Power supply 220-240V ~ 50Hz

Electrical current consumption of the DHW Electric heater	A	10,1
Power input of the DHW Electric heater	kW	2
Total electrical current consumption	A	11,6
Total power input	kW	2,3

Power supply 220-240V ~ 50Hz +/-10.

The units comply with the requirements of European standard IEC EN 60335.

Indoor unit pressure drops

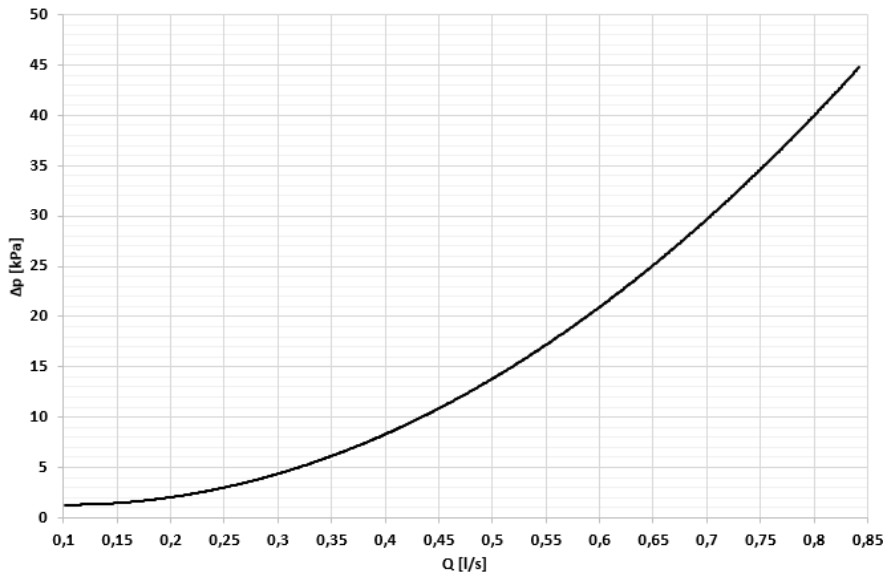

ΔP [kPa] = Pressure drops
Q [l/s] = Water flow-rate

Note: STANDARD indoor unit pressure drops

Available pressure

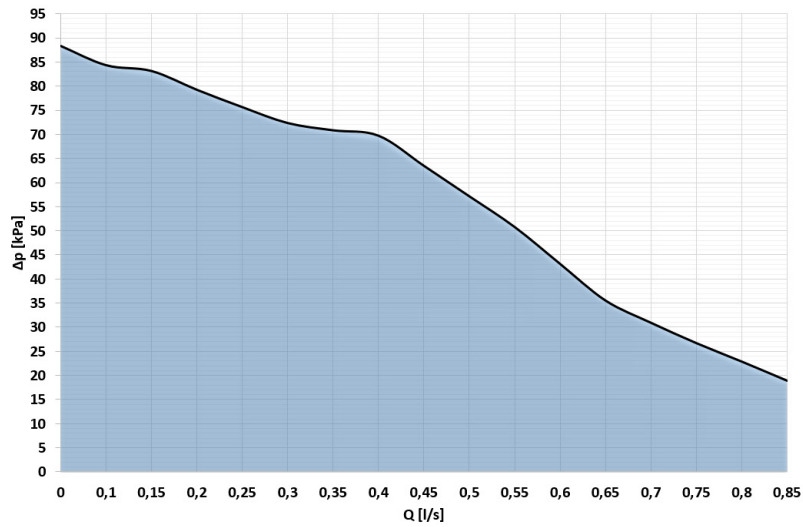

ΔP [kPa] = Available pressure
Q [l/h] = Water flow-rate

Circulator operating range

Hydraulic connections

Hydraulic line sizing

Equivalent length of the lines (metres) = actual length (metres) + quantity of bends x K
 Use the K value from the following table

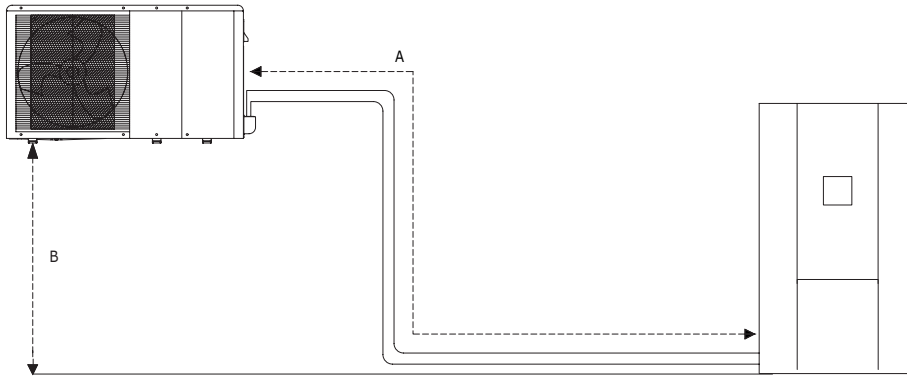

SIZE		2.1	3.1	4.1	5.1	6.1	7.1	8.1
K values								
standard 90° elbow bend	m	0,6	0,6	0,6	0,6	0,9	0,9	0,9
45° bend (standard)	m	0,3	0,3	0,3	0,3	0,3	0,3	0,3
Length and height difference of hydraulic lines								
A- Minimum and maximum connection distance between indoor and outdoor units	m	2 - 25	2 - 25	2 - 25	2 - 25	2 - 20	2 - 15	2 - 15
B- Maximum height difference between indoor and outdoor units	m	20	20	20	20	15	15	15

Note: recommended diameter, the one the same size as the connection on the outdoor unit.

General description of the system and possible connections

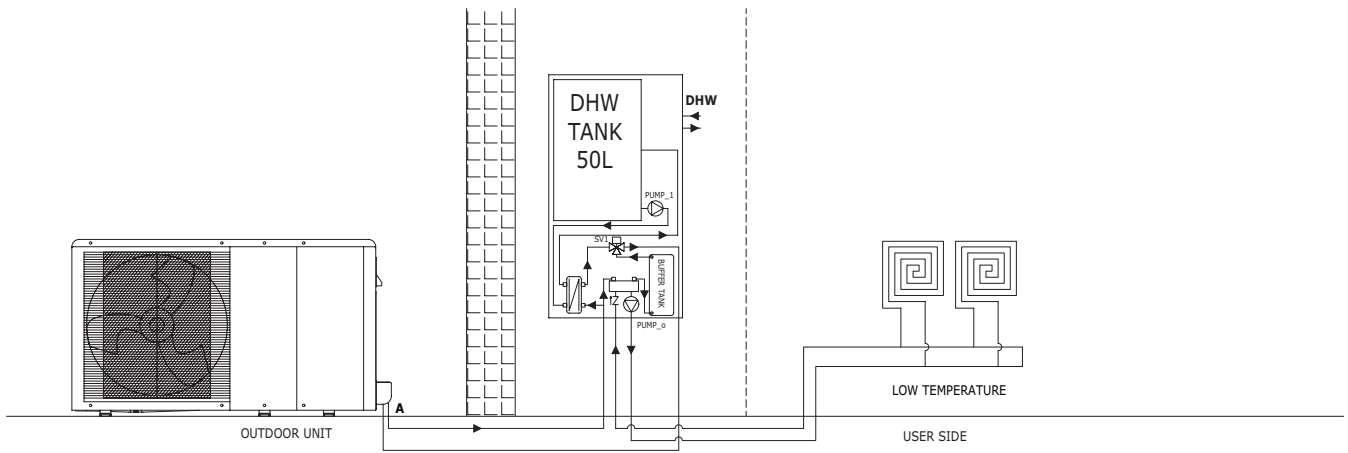

Standard

Dimensional drawings

EASYMINI

DAATJ0000 - REV00
DATA/DATE 28/05/2024

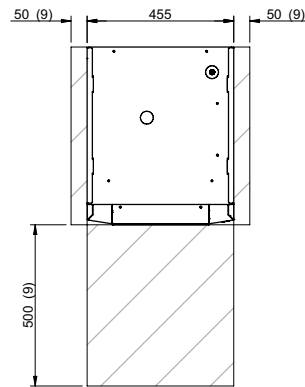
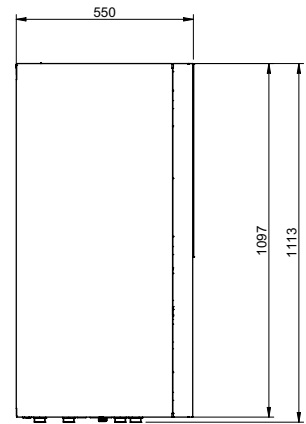
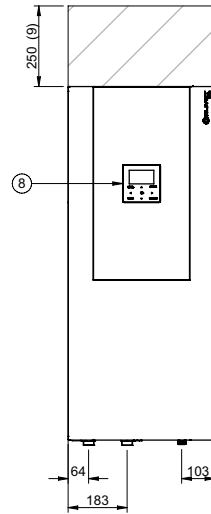
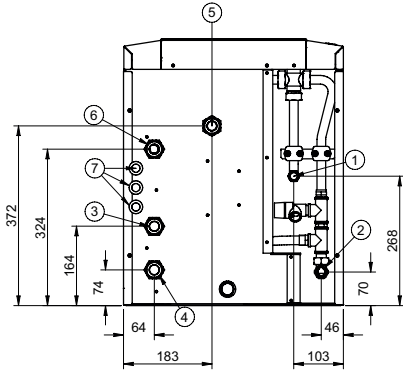

1. Domestic hot water outlet M 1/2"
2. Water supply system inlet F 1/2"
3. Return to outdoor unit M 1"
4. Supply from outdoor unit M 1"
5. Return from user side system M 1" area 1
6. Supply from user side system M 1" area 1
7. power line inlet
8. Control keypad
9. Functional spaces for standard unit

SIZE

Operating weight	kg	140
Shipping weight	kg	84

The presence of optional accessories may result in significant variation of the weights indicated.

Page intentionally left blank

Page intentionally left blank

FOR 35 YEARS WE HAVE BEEN OFFERING
SOLUTIONS TO ENSURE SUSTAINABLE
COMFORT AND THE WELL-BEING OF
PEOPLE AND THE ENVIRONMENT

www.clivet.com

MideaGroup
humanizing technology

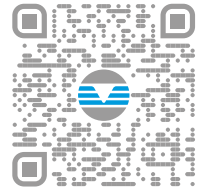

sale and assistance

(Valid from: 2024 - (revision 00/2024
BT24G051GB-00



CLIVET S.p.A.

Via Camp Lonc 25, Z.I. Villapaiera 32032 - Feltre (BL) - Italy

Tel. +39 0439 3131 - info@clivet.it

CLIVET GMBH

Hummelsbütteler Steindamm 84,
22851 Norderstedt, Germany
Tel. +49 40 325957-0 - info.de@clivet.com

Clivet Group UK LTD

Units F5 & F6 Railway Triangle,
Portsmouth, Hampshire PO6 1TG
Tel. +44 02392 381235 -
Enquiries@Clivetgroup.co.uk

CLIVET LLC

Office 508-511, Elektrozavodskaya st. 24,
Moscow, Russian Federation, 107023
Tel. +7495 6462009 - info.ru@clivet.com

CLIVET MIDEAST FZCO

Dubai Silicon Oasis (DSO) Headquarter Building,
Office EG-05, P.O Box-342009, Dubai, UAE
Tel. +9714 3208499 - info@clivet.ae

Clivet South East Europe d.o.o.

Jarušćica 9b
10000, Zagreb, Croatia
Tel. +3851 222 8784 - info.see@clivet.com

CLIVET France SAS

6 Allée Kepler,
77420 Champs-sur-Marne
France
mail: info.fr@clivet.com
Tel: +33 1 88 60 99 40

Clivet Airconditioning Systems Pvt Ltd

Office No.501 & 502,5th Floor, Commercial -I,
Kohinoor City, Old Premier Compound, Off LBS
Marg, Kirod Road, Kurla West, Mumbai
Maharashtra 400070, India
Tel. +91 22 30930200 - sales.india@clivet.com