

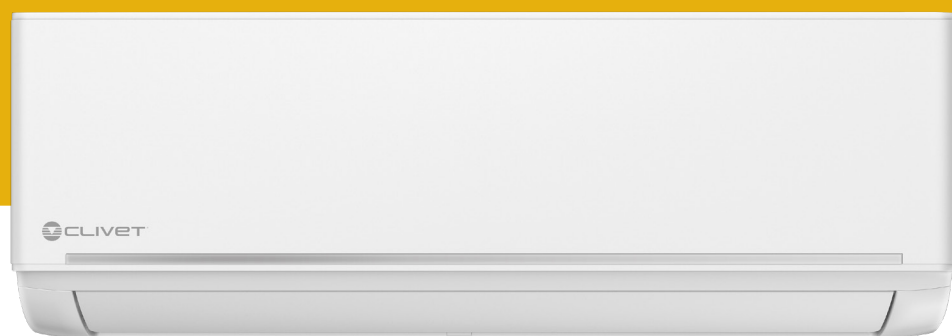

EZCool

ILA1-Y series from 27M to 70M

MANUAL
FOR INSTALLATION,
USE AND MAINTENANCE



en

M0EC00002-01
04-2024

INTRODUCTION

Dear Customer,

Thank you for choosing a **CLIVET** product.

The **EZCool** model which you have chosen, is a high performance product of advanced design and technology, high reliability and quality construction.

We suggest that you entrust its management and maintenance to professionally qualified personnel you trust, who, when necessary, only use original spare parts.

This manual contains important information and tips that must be followed for easier installation and the best possible use of the appliance.

RANGE

SINGLE Split systems		MULTI Split systems	
EZCool	ILA1-Y + MLA1-Y series from 27M to 70M	EZCool	ILA1-Y series from 27M to 70M

SYMBOLS USED IN THE MANUAL AND THEIR MEANING



WARNING

To indicate special information.



CAUTION

To indicate particularly important and delicate operations.



CAUTION DANGER

To indicate actions which, if not carried out correctly, may result in general accidents or may cause malfunctions or material damage to the device; therefore, they require special attention and adequate preparation.



ATTENTION ELECTRIC DANGER

To indicate actions which, if not carried out correctly, may result in accidents of electrical origin; therefore, they require special attention and adequate preparation.



IT IS PROHIBITED

To indicate actions that **MUST NOT** be performed.



FLAMMABLE MATERIAL

Indicates that the appliance uses a flammable refrigerant.

WARRANTY

The product **CLIVET** is covered by a **conventional warranty**, valid from the date of purchase of the appliance, the conditions of which are specified in the GENERAL CONDITIONS OF SALE available at www.clivet.com



WARNING

- The warranty is void if the appliance has been used without following the instructions in this manual.
- The warranty will be forfeited if the customer makes changes and/or attempts to repair the product himself or through third parties not authorised by the manufacturer/authorised dealer.
- The product must be intended for the use intended by **CLIVET** for which it was expressly made. Any contractual and non-contractual liability **CLIVET** for damage caused to persons, animals or property by installation, adjustment, maintenance and misuse errors is excluded.

INDEX

1 General Details	4	4 Maintenance.....	25
1.1 General warnings and safety rules	4	4.1 Cleaning the indoor unit	25
1.2 Description of SINGLE Split system components	6	4.2 Cleaning the air filter	25
1.3 Description of MULTI Split system components	7	4.3 Cleaning the outdoor unit	26
1.4 Accessories	7	4.4 Extended periods of inactivity	26
1.5 Identification	8	4.5 Maintenance at the start of the season	26
2 Installation	9	4.6 Troubleshooting	27
2.1 Product receiving	9	4.6.1 Common problems	27
2.2 Size and weight	9	4.6.2 Abnormalities and remedies	28
2.3 Installation - preliminary warnings	9	4.7 Error codes displayed on the indoor unit display	29
2.4 Indoor unit installation	10	5 Disposal	32
2.4.1 Installation room	10	6 Attachments	33
2.4.2 Mounting plate	12	6.1 Indoor unit wiring diagrams	33
2.4.3 Preparation for connection pipes	14	6.2 Conformance Statement	35
2.4.4 Preparation for refrigerant piping	15		
2.4.5 Drainage pipe	16		
2.4.6 Electrical connections	17		
2.4.7 Wrap the pipes and cables	18		
2.4.8 Mounting the indoor unit	19		
3 Use.....	20		
3.1 Description of system components	20		
3.2 Meaning of the display codes	20		
3.3 Remote control	21		
3.4 Operation	21		
3.4.1 Other functions	22		
3.4.2 Airflow angle adjustment	23		
3.5 Manual operation (without remote control)	24		



Section dedicated to the USER

1 GENERAL DETAILS

1.1 General warnings and safety rules



WARNING

- This manual is the property of CLIVET and reproduction or transfer to third parties of the contents of this document is prohibited. All rights reserved. It is an integral part of the product; make sure that it is always supplied with the appliance, even in case of sale/transfer to another owner, so that it can be consulted by the user or by personnel authorized to carry out maintenance and repairs.
- Read this manual carefully before using the unit to ensure its safe operation.
- Periodically check the integrity of the power cord, plug and related socket. If the power cable is damaged, it may only be replaced by the manufacturer or the local distributor who sold the appliance or by authorised maintenance and repair personnel.
- The installation must be carried out by an authorized dealer or a qualified technician. Faulty installation may result in water leakage, electric shock or fire.
- Work on the refrigerant circuit must only be carried out by persons with a valid certification, issued by an accredited body, certifying their competence to handle refrigerants safely in compliance with the specifications in force in the sector.
- The installation must be carried out according to the instructions provided. An incorrect installation may cause water leaks, electric shock or fire.
- Install the drain hose according to the instructions in this manual. Incorrect draining can cause water seepage or flooding with possible damage to the home and other property.
- The device must be stored in such a way as to prevent any mechanical damage.
- Consult a qualified technician for unit repair or maintenance.
- Perform the installation using only the supplied accessories and parts specified. The use of non-standard components may cause water leakage, electric shock or fire and cause the unit to malfunction.
- Do not use any means other than those recommended by the manufacturer to accelerate the defrosting process or to clean the unit.
- The appliance must be placed in a room that does not contain any ignition sources operating continuously (e.g. open flames, gas appliances or electric heaters).
- Note that the coolants are odourless.
- Always use the specified cables for all electrical work. Connect the cables securely and secure them in a stable manner to prevent the terminals from being damaged by external forces. Incorrect electrical connection may cause overheating conditions and may result in fire and electrocution.
- The cables must be arranged so that the control board cover can close properly. If the control board cover is not closed properly, corrosion may occur and the connection points on the terminals may become hot, ignite or cause electric shock.
- In some functional environments such as kitchens, server rooms, etc., it is recommended to use specially designed air conditioners.
- The appliance is only suitable for use by children 8 years old and over and persons with reduced physical, sensory or mental capabilities or lack of experience or knowledge when they are properly supervised or have received instructions on the safe use of the appliance and have understood the associated dangers. Prevent children from playing with the appliance. Cleaning and maintenance operations must not be carried out by children without supervision.
- For electrical work, comply with the provisions of the national electrical code, local regulations, current regulations and the requirements contained in the installation manual. It is necessary to use an independent circuit and a single power outlet. Do not connect other appliances to the same electrical outlet. Insufficient electrical capacity or faulty electrical installation may cause risk of electric shock or fire.



CAUTION DANGER

- When connecting refrigerant piping, keep substances or gases other than the specified refrigerant from entering the unit. The presence of other gases or substances can reduce unit performance and cause an abnormal increase in pressure in the refrigeration cycle. This can lead to explosion hazards and resulting injuries.
- Install the unit on a stable stand that can support its weight. If the chosen stand cannot support the weight of the unit, or if the installation is not performed correctly, the unit may fall and cause injury and serious damage.
- Do not pierce or ignite the device.
- The appliance must be placed in a well-ventilated room whose dimensions correspond to those specified for operation.
- The product must be installed with earthing in accordance with the law to avoid the risk of electrocution.
- Do not install the unit in a location that may be exposed to combustible gas leakage. Any accumulation of combustible gas around the unit may cause a fire hazard.
- Do not operate the air conditioner in a very humid room, for example in a bathroom or laundry room. Excessive exposure to water can cause electrical components to short-circuit.



IT IS PROHIBITED TO

- Make changes and/or repair attempts to the product. Any repairs must be carried out by a qualified technician.
- Touch the device with wet, damp and/or barefoot body parts. If you notice current leakage that can be detected on contact with metal parts of the appliance, disconnect the switch, unplug it from the power supply socket and contact an authorised dealer.
- Use of the appliance by children and persons with reduced capacity or lack of experience and specific knowledge unless they are assisted by qualified personnel responsible for their safety.
- Disperse in the environment and leave within the reach of children the packaging material as it may be a potential source of danger. It must therefore be disposed of in accordance with current legislation.
- Change the length of the power cable or use extension cables to power the unit.
- Use the same electrical outlet for other equipment. Incorrect or insufficient power supply may cause fire or electric shock hazard.



NOTES ON FLUORINATED GASES

- This air conditioner contains fluorinated gas. For specific information on gas types and quantities, please refer to the plate found on the unit. It is always necessary to comply with national regulations regarding the use of gases.
- Installation, service, maintenance and repair of the unit must be performed by a qualified technician.
- The uninstallation and recycling of the product must be carried out by qualified technical personnel.
- If a leak detection device is installed in the system, it is necessary to check that there are no leaks at least every 12 months. When checking the unit for leaks, it is recommended to keep a detailed record of all inspections.
- Pay attention to the fact that refrigerant R32 is odourless.



FLAMMABLE MATERIAL

The refrigerant used inside this unit is flammable. A coolant leak that is exposed to an external ignition source can create fire risks

1.2 Description of SINGLE Split system components

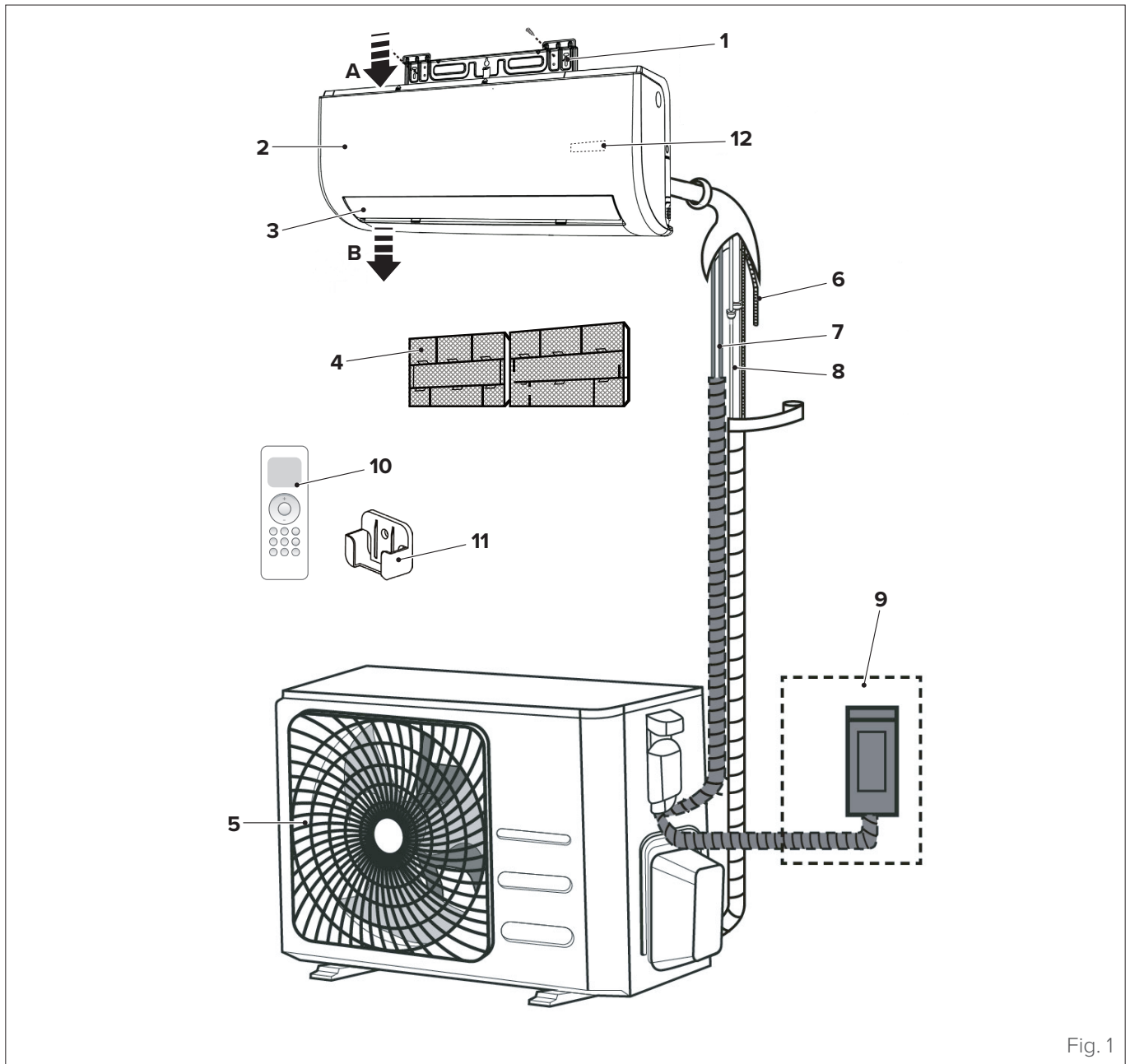

Fig. 1

- | | |
|-------------------------------|--|
| A Air return | 6 Flexible drainage condensate hose |
| B Air supply | 7 Electrical connection |
| 1 Wall-fixing template | 8 Refrigerant piping |
| 2 Indoor unit | 9 Outdoor unit power supply |
| 3 Ventilation slit | 10 Remote control |
| 4 Air filter | 11 Remote control support |
| 5 Outdoor unit | 12 Display LED |

**WARNING**

The images in this manual are provided for illustrative purposes only. The appearance of your device may differ slightly from the illustrations shown here. Refer to the actual characteristics of the unit.

1.3 Description of MULTI Split system components

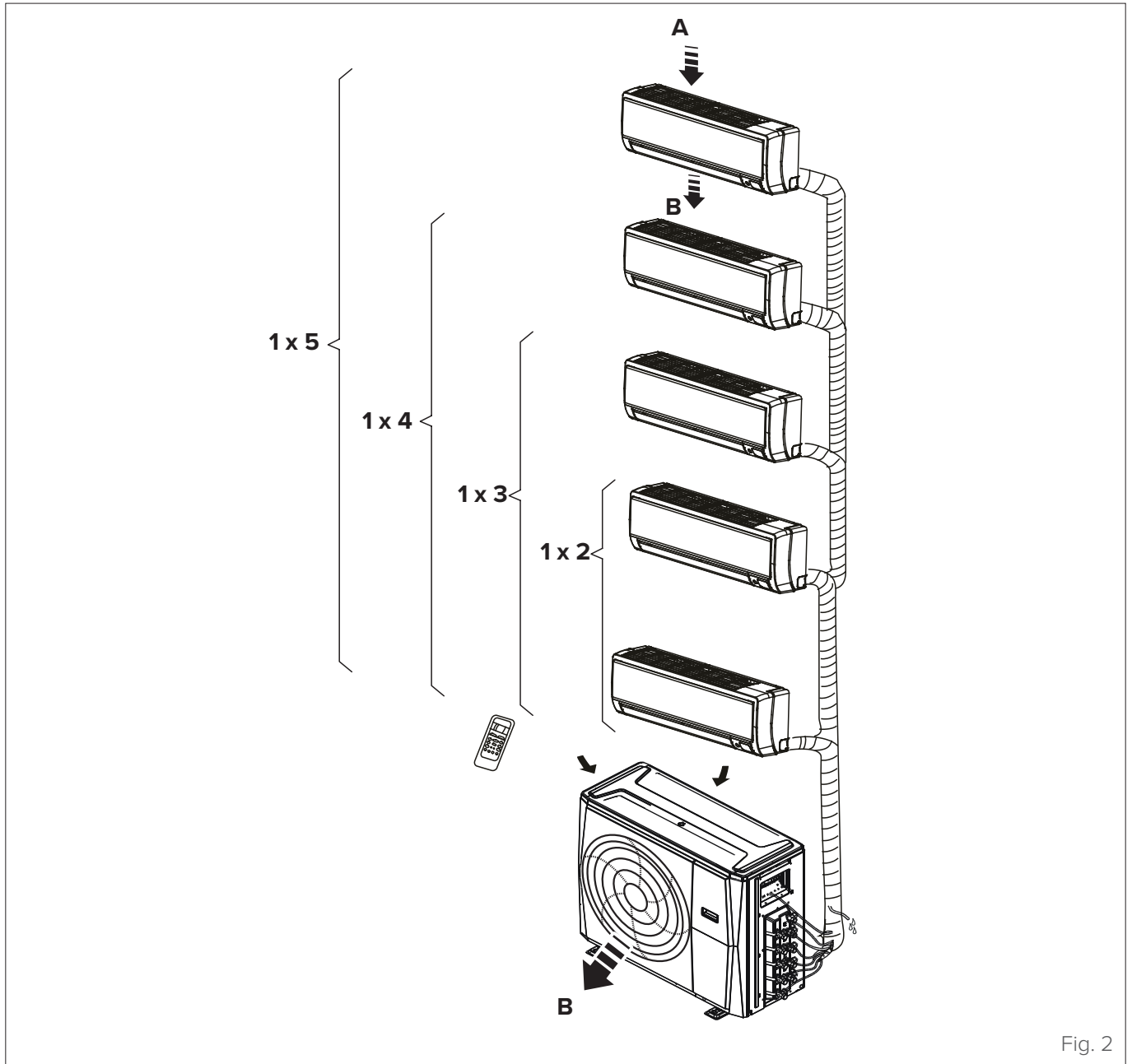
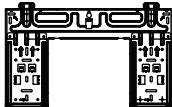

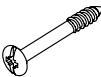

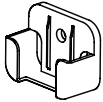

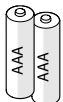



Fig. 2

1.4 Accessories

The air conditioner is equipped with the following accessories. Use all specified installation components and accessories to install it. Incorrect installation may cause water leakage, electric shock and fire, or cause the unit to malfunction.

Description	Aspect	Quantity
Mounting plate		1
Gusset		5
Fixing screw for mounting plate ST3.9 X 25		5

Description	Aspect	Quantity	
Remote control		1	
Remote control support		1	
Fixing screw for the ST2.9 x 10 remote control holder		2	
AAA Alkaline battery. LR03		2	
Installation use and maintenance manual		1	
Connection pipe unit	Liquid side	Ø 6.35 mm (1/4")	Components to be purchased separately. Consult your dealer for pipe sizes.
		Ø 9.52 mm (3/8")	
	Gas side	Ø 9.52 mm (3/8")	
		Ø 12.7 mm (1/2")	
		Ø 15.9 mm (5/8")	

1.5 Identification

The indoor unit and the outdoor unit can be identified by the serial number label that shows the technical and performance data of the unit and what is required by the legislation in force.

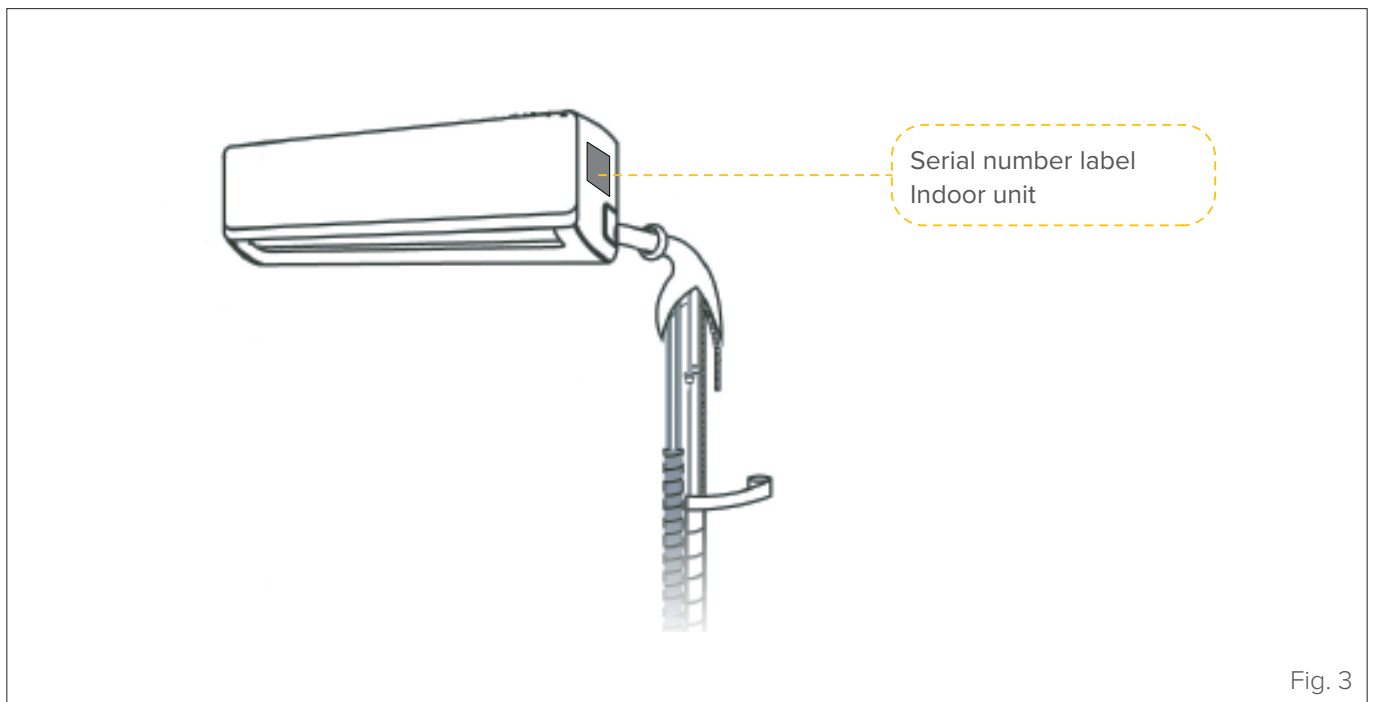

Fig. 3



CAUTION

Tampering, removal, lack of identification labels or anything else that does not allow safe product identification, makes any installation and maintenance operation difficult.

2 INSTALLATION

2.1 Product receiving

The appliance is supplied packed in several parcels. Handling must be carried out by appropriate means in view of the overall weight of the package.

Upon receiving the appliance, check the perfect integrity of all parts.

In case of damage to the equipment or missing material, please contact your authorised dealer promptly.



WARNING

The manual is an integral part of the product and therefore it is recommended that you read it before installing and commissioning the device and keep it with care for future reference or transfer to another Owner or User.



IT IS PROHIBITED

disperse in the environment and leave within the reach of children the packaging material as it can be a potential source of danger. It must be disposed of in accordance with current legislation.

2.2 Size and weight

	Indoor unit			
	27M	35M	53M	70M
Width (mm)	726	802	969	1083
Depth (mm)	210	200	241	244
Height (mm)	291	295	320	336
Weight (kg)	7,7	8,2	11,2	13,6

2.3 Installation - preliminary warnings



WARNING

Before installing the indoor unit, consult the label on the product package to check that the model number matches the model number of the outdoor unit.



ATTENTION ELECTRIC DANGER

- All electrical connections must be done by a licensed electrician according to the provisions of national and local electrical codes.
- All electrical connections must be made according to the wiring diagram on the panels of the indoor and outdoor units.
- If the electrical system has serious safety problems, stop work immediately. Explain the situation to the customer and refuse to install the unit until the security problem has been resolved.
- The power supply should correspond to 90-100% of the nominal voltage. Insufficient power supply may cause malfunction, electric shock or fire.
- If the power cables are permanently installed connected to the electrical system, install overcurrent protection and a main power switch with a capacity of 1.5 times the maximum current of the unit.
- The supply line must have a special protection upstream against short circuits and earthing leakage that sections the system with respect to other utilities. The technician must choose an approved differential circuit-breaker or main circuit breaker.
- Connect the unit to a single socket of a dedicated branch of the circuit. Do not connect other appliances to the same electrical outlet.
- The air conditioner must be properly grounded.
- All cables and conductors must be connected securely. Loosening a conductor may cause the terminal to overheat, which in turn may result in fire hazards or product malfunction.
- The electrical cables must not touch or rest against the refrigerant pipes, the compressor or any moving parts of the unit.

2.4 Indoor unit installation

2.4.1 Installation room



CAUTION

The appliance must be placed in a well-ventilated room, with a minimum surface area that varies according to the amount of refrigerant present.

To calculate the minimum area of the installation room, proceed as described below:

- determine the total refrigerant charge (see section “3.1.1 Refrigerant charge” of the outdoor unit manual)
- identify the refrigerant charge value in the table below and derive the respective minimum area required for the installation room.

Refrigerant charge [kg]	Minimum surface [m ²]
<1.224	-
1.225	1.43
1.4	1.87
1.6	2.44
1.8	3.09
2.0	3.81
2.2	4.61
2.4	5.49
2.6	6.44
2.8	7.47
3.0	8.58
3.2	9.76
3.4	11.0
3.6	12.4
3.8	13.8
4.0	15.3
4.2	16.8
4.4	18.5
4.6	20.2
4.8	22.0
5.0	23.8
5.2	25.8
5.4	27.8
5.6	29.9
5.8	32.1
6.0	34.3
6.2	36.6
6.4	39.1

Refrigerant charge [kg]	Minimum surface [m ²]
6.6	41.5
6.8	44.1
7.0	46.7
7.2	49.4
7.4	52.2
7.6	55.1
7.8	58.0
7.956	61.0

The following information can help you choose a suitable location for the indoor unit.

The installation location must have the following characteristics:

- good air circulation
- ease of drainage
- the noise emitted by the unit must not disturb other people
- stability and robustness - no exposure to vibration
- sufficient capacity to support the weight of the unit
- at least one metre away from any other electrical device (e.g. TV, radio, computer)



It is PROHIBITED to install the indoor unit in the following locations:

- near sources of heat, steam or combustible gas;
- near flammable objects, such as curtains or fabrics;
- near obstacles that could obstruct air circulation;
- near the entrance;
- In a an area that is not exposed to direct sunlight.



NOTE ON THE HOLE IN THE WALL

If there is no fixed refrigerant piping:
When choosing the installation position, it is recommended to provide a sufficiently large space for the wall hole (see paragraph “2.4.3 Preparation for connection pipes”) in which to insert the signal cable and the refrigerant piping between the indoor and outdoor units. The usual position for cables and pipes is on the right side of the indoor unit (looking at the unit). However, the unit supports installation of cables and piping both on the left and on the right.

Please refer to the following diagram for wall and ceiling distances:

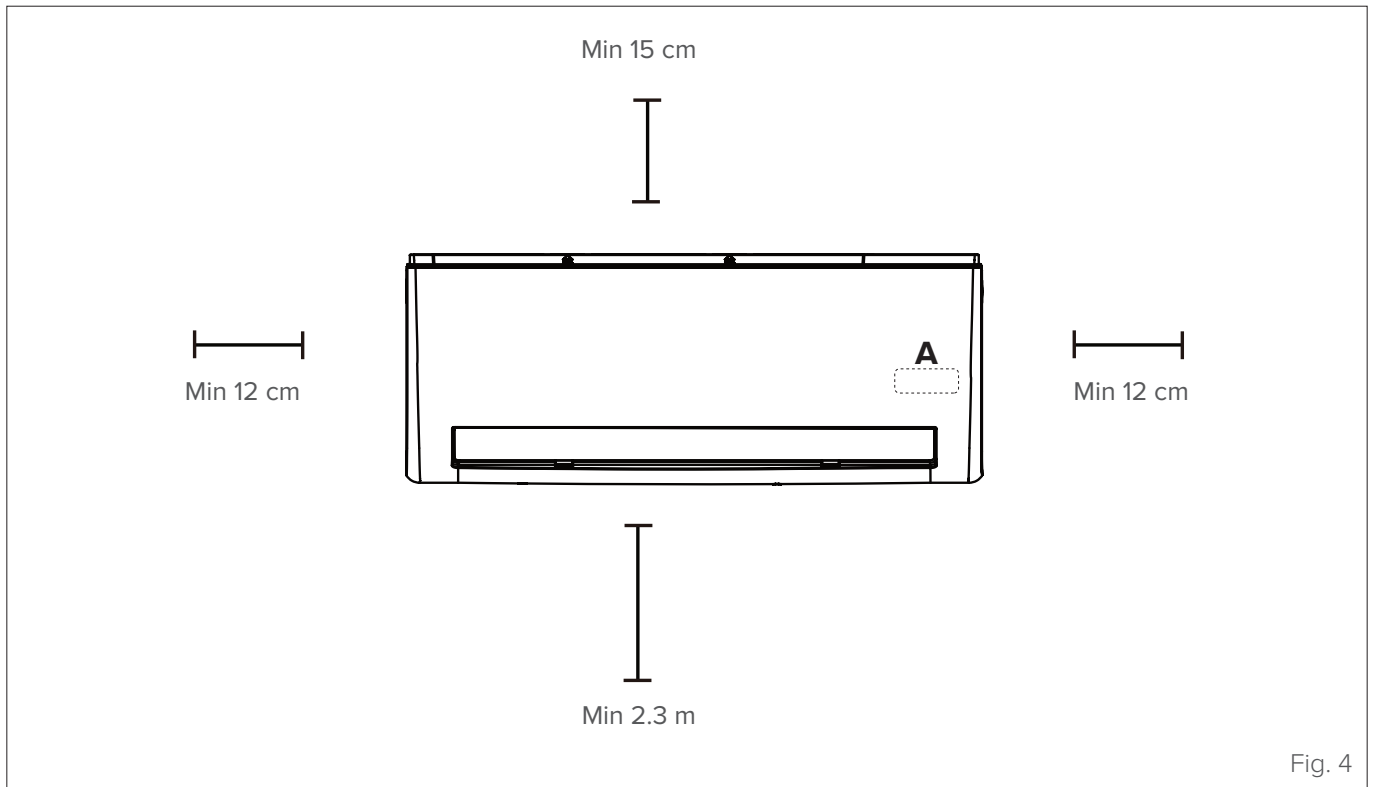

A Position of the display EZCool and remote control signal receiver.

NOTE: The receiver must be left free of obstacles that could affect reception from the remote control.

2.4.2 Mounting plate

MOUNTING PLATE DIMENSIONS

The mounting plate is used to fix the indoor unit to the wall.

Correct orientation of the mounting plate

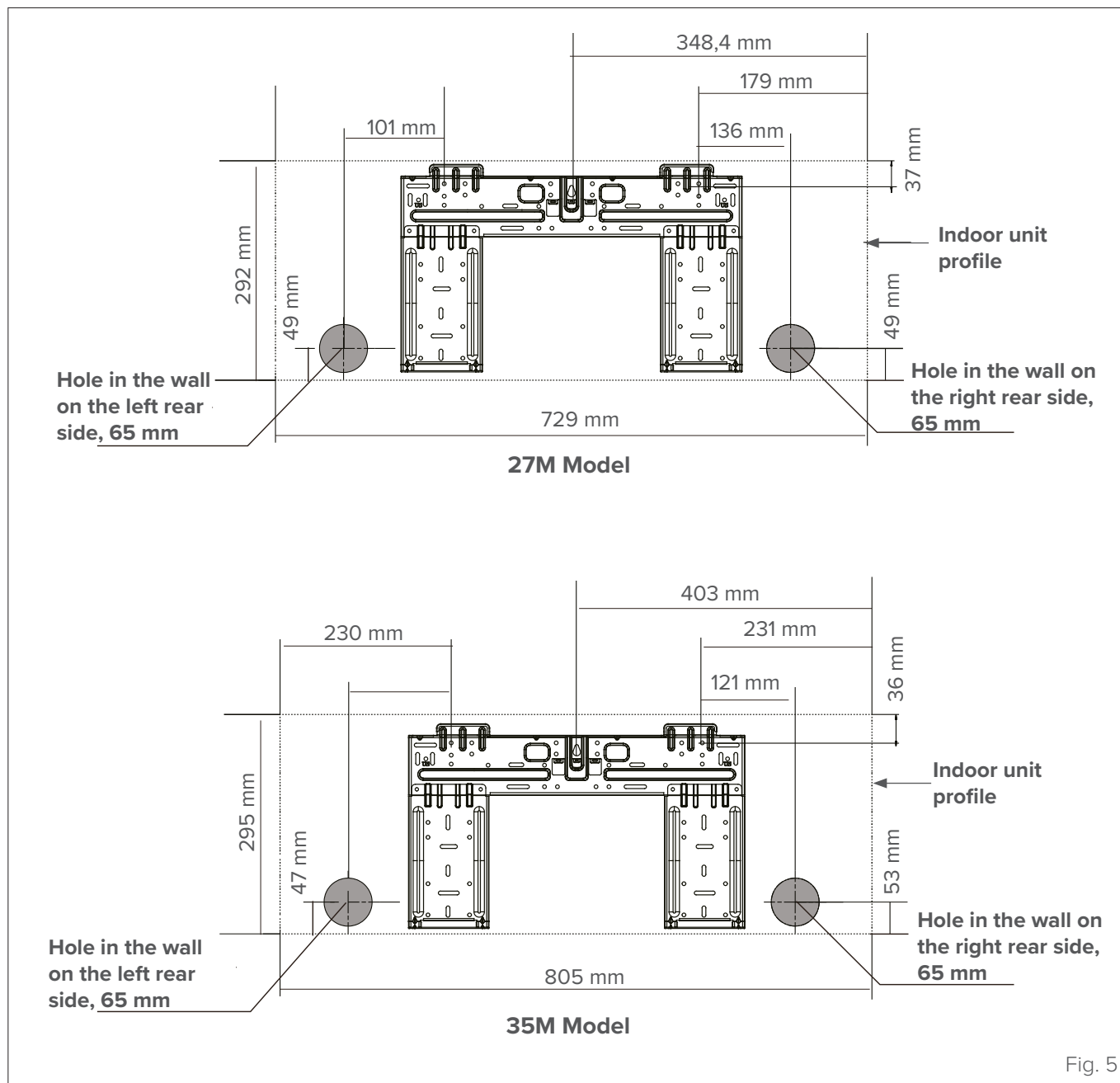
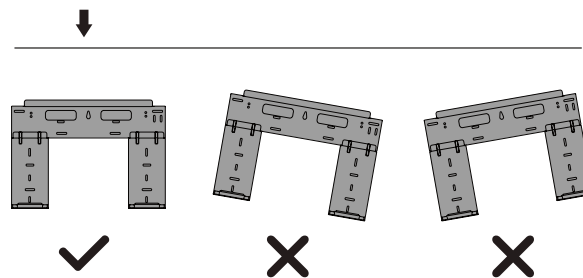

Fig. 5

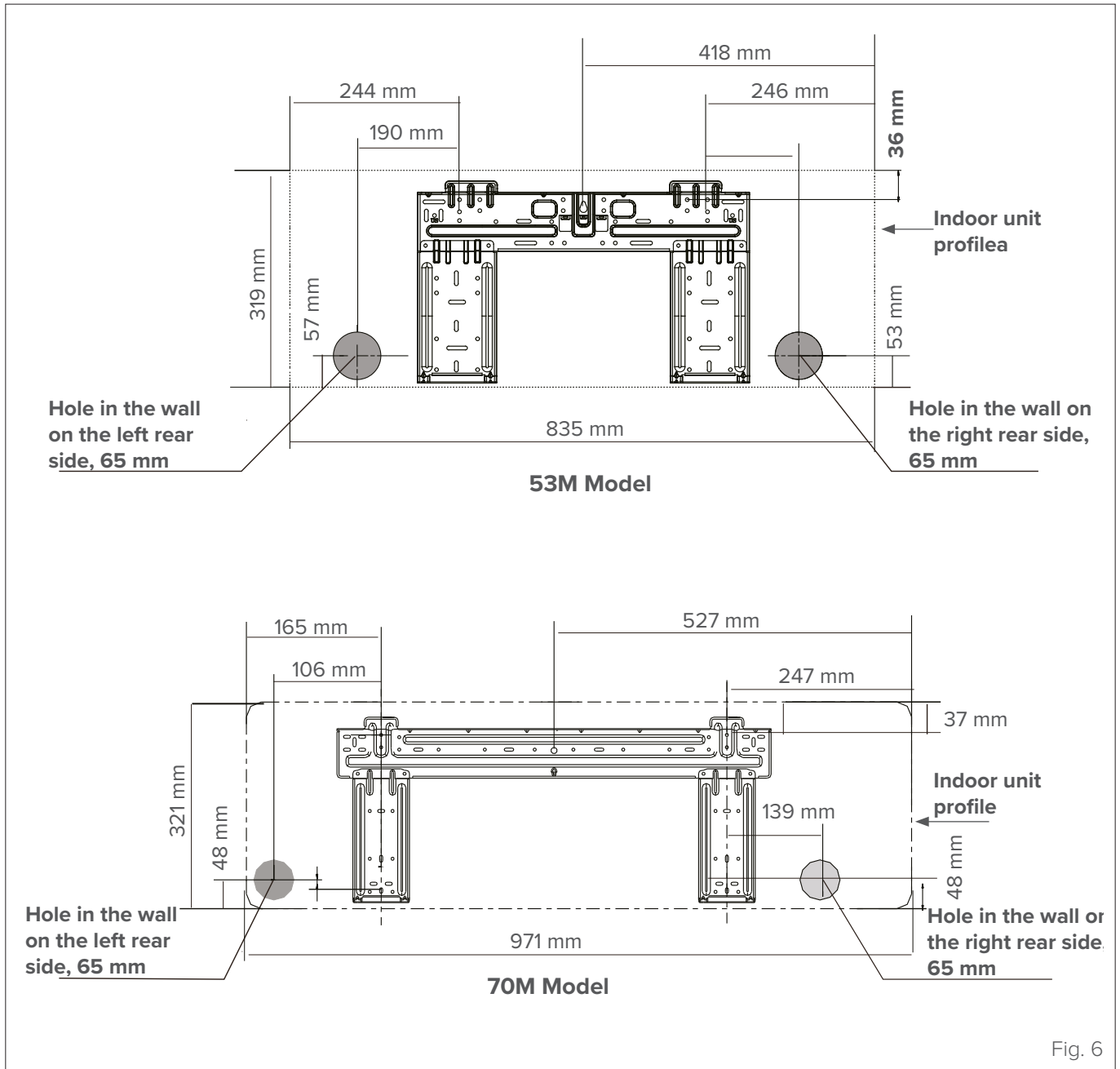

Fig. 6

FIX THE MOUNTING PLATE TO THE WALL

- 1 Remove the screw that fastens the mounting plate to the back of the indoor unit.
- 2 Place the mounting plate on the wall in a position that meets the requirements listed in paragraph “2.4.1 Installation room” (for detailed information on the dimensions of the mounting plate see “Mounting plate dimensions”).
- 3 Drill the holes for the fixing screws in positions that:
 - are strong enough and have sufficient capacity to support the weight of the unit
 - match the holes in the mounting plate
- 4 Fix the mounting plate to the wall using the screws provided.

- 5 Check that the mounting plate is in line against the wall.



WARNING

If the wall is made of brick, concrete or similar materials, drill holes with a diameter of 5 mm and insert the anchors provided. Then fix the mounting plate to the wall by tightening the screws directly into the anchors. If the wall is made of other materials, use suitable fasteners and check that they are properly sealed.

2.4.3 Preparation for connection pipes

It is necessary to make a hole in the wall where the refrigerant piping, drainage pipe and electrical cables that will connect the indoor unit to the outdoor unit will pass through.



WARNING

The refrigerant piping can come out of the indoor unit at four different angles:

- Left side
- Rear left side
- Right side
- Rear right side

For more details see “Fig. 7”

Reversibility connections

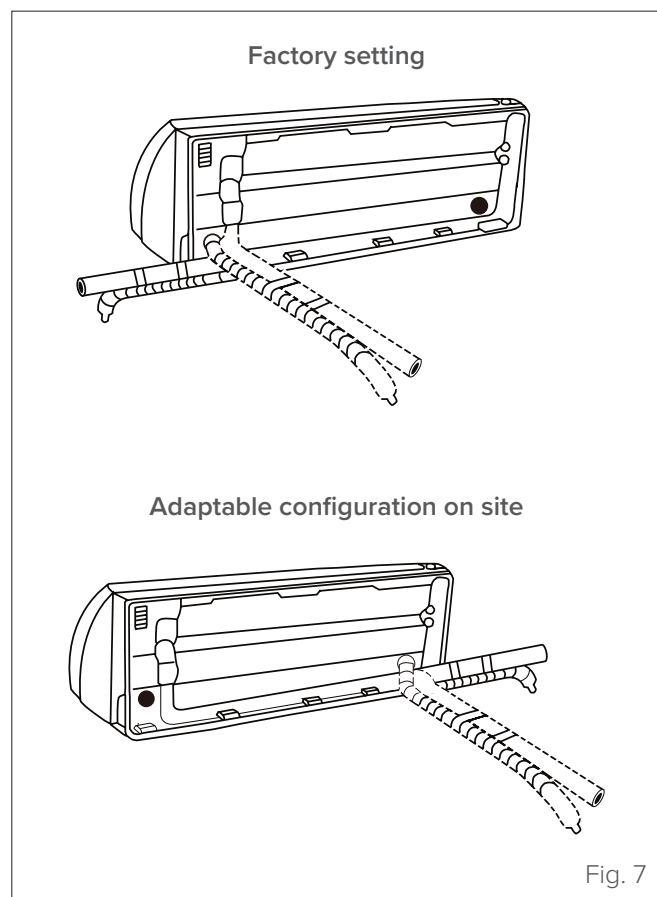

Fig. 7

- 1 Determine hole position according to the position of the mounting plate. To help you choose the optimal position, refer to point “Mounting plate dimensions”. The hole in the wall should have a minimum diameter of 65 mm and a slight downward slope to facilitate drainage (see “Fig. 8”).
- 2 Drill the hole in the wall using a 65 mm drill bit. The hole should have a slight inclination, so that the outer end is lower than the inner one by about 5-7 mm. This will facilitate water drainage.

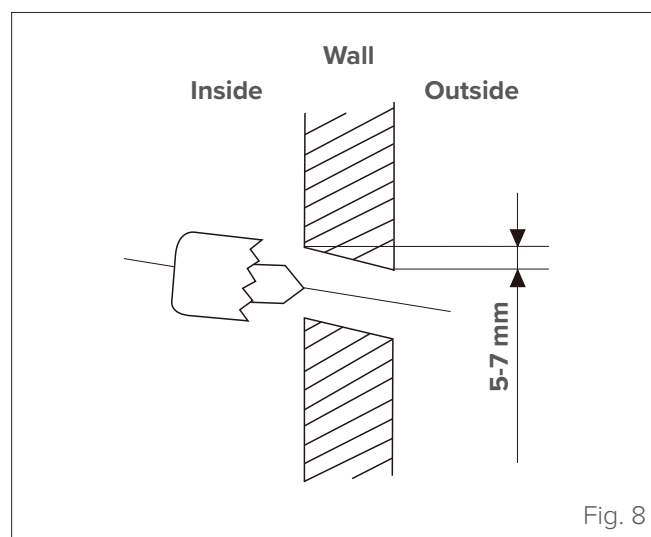

Fig. 8

- 3 Insert the protective sleeve into the wall, which will protect the edges of the hole and improve the seal after installation.



CAUTION DANGER

When drilling holes, be careful to avoid electrical wires, hydraulic hoses and other delicate components.

2.4.4 Preparation for refrigerant piping

The refrigerant piping is located inside an insulating sleeve fixed on the back of the unit. It is necessary to prepare the pipes before passing them through the hole in the wall. For detailed instructions on countersinking pipes and the required tightening techniques and torques, refer to section “6 Notions on refrigerant piping connection” of the outdoor unit manual.

- 1 Depending on the position of the wall hole in relation to the mounting plate, choose the side from which the refrigerant piping will exit the unit.
- 2 If the wall hole is behind the unit, leave the pre-cut panel in place. If the wall hole is on the side of the indoor unit, remove the pre-cut plastic panel from the side of the unit using a jig saw (see “Fig. 9”).

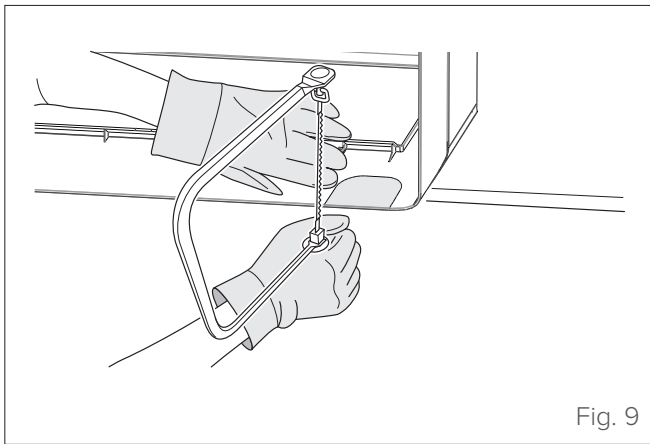

Fig. 9

- 3 Remove any burrs along the cut section using a half round file.

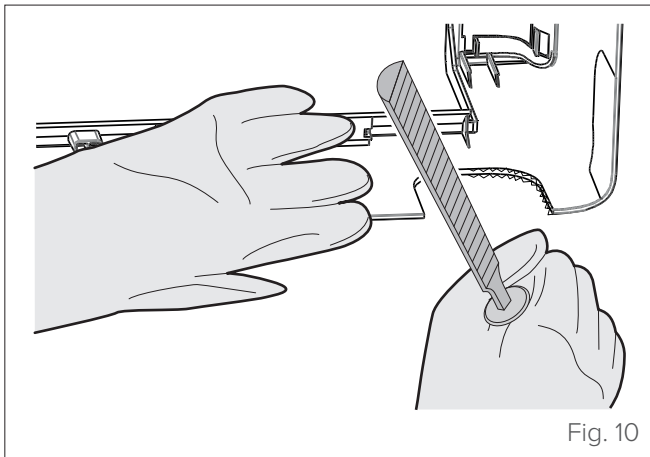

Fig. 10



IT IS PROHIBITED

use pliers to remove the pre-cut panel as this may damage the front grille.

- 4 Using scissors, cut the insulation sleeve so that about 15 cm of the refrigerant piping is exposed. This operation has a double utility:
 - it facilitates connection of refrigerant piping
 - it makes it easier to check for gas leaks and to check for indentations
- 5 If the connection pipes are already embedded in the wall, proceed directly to paragraph “2.4.5 Drainage pipe”. If there are no pipes already prepared, connect the refrigerant piping of the indoor unit to the connection pipe between the indoor unit and the outdoor unit. Refer to section “6 Notions on refrigerant piping connection” of the outdoor unit manual for detailed instructions.
- 6 Depending on the position of the wall hole in relation to the mounting plate, determine the angle required for the pipe.
- 7 Grab the refrigerant line at the base of the bend.
- 8 Slowly, applying uniform pressure, bend the pipe towards the hole. Take care to **not to dent or damage the pipe**.



CAUTION

Do not dent or damage the pipe when bending it compared to the unit. Any recesses in the pipe will adversely affect unit performance.

2.4.5 Drainage pipe

In the default configuration, the drainage pipe is connected to the left side of the unit (looking at the back of the unit). However, it can also be connected to the right side.

- 1 To ensure proper drainage, secure the drainage pipe on the same side as the refrigerant piping.
- 2 Attach the drainage pipe extension (to be purchased separately) to the end of the pipe.
- 3 Tightly wrap the connection joint with Teflon tape to ensure a good seal and prevent possible leakage.
- 4 The part of the drainage pipe that remains inside should be wrapped in a foam sleeve to prevent condensation from forming.
- 5 Remove the air filter and pour a small amount of water into the drain pan to make sure the water is draining properly from the unit.



WARNING

To prevent unwanted leakage, the unused drain hole must be closed using the rubber cap provided.

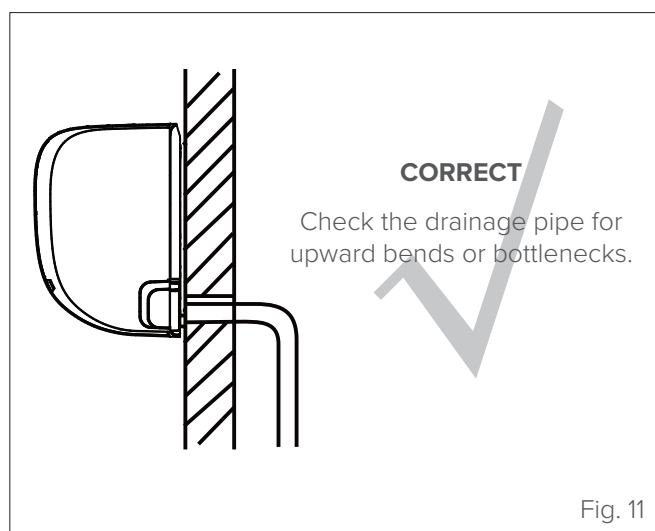

IT IS PROHIBITED

- bend the drainage pipe upwards;
- create stagnation points;
- submerge the end of the drainage pipe in water or in a water collection container.

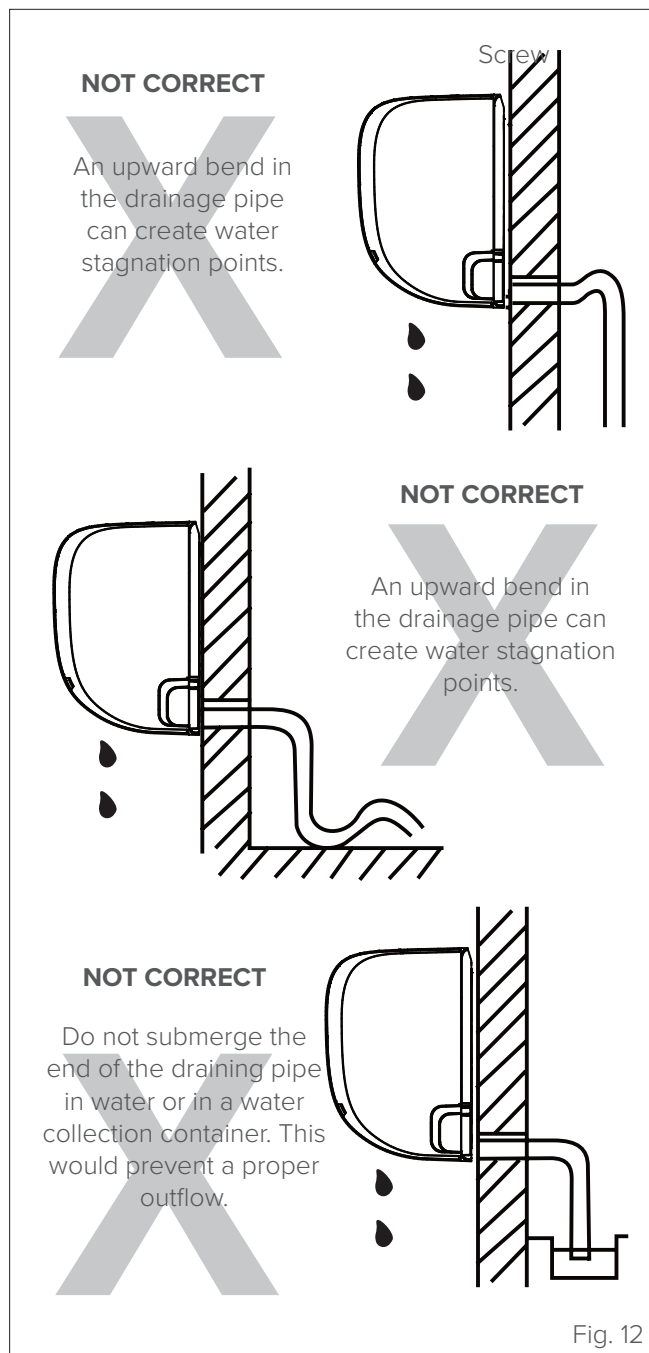

2.4.6 Electrical connections

Cables with the following characteristics are required for power supply and communication between the indoor and outdoor units:

Indoor unit	Power supplied from outdoor unit	Signal from outdoor unit
	n° cables/cross section	n° cables/cross section
27M	2 x 1,5mm ² + G	2 x 1,5mm ²
35M	2 x 1,5mm ² + G	2 x 1,5mm ²
53M	2 x 1,5mm ² + G	2 x 1,5mm ²
70M	2 x 2,5mm ² + G	2 x 2,5mm ²

The indicated cross-sections are suitable for a wiring length of up to 5 metres.



ATTENTION ELECTRIC DANGER

Before making electrical connections, turn off the main switch of the system.



WARNING

WRITE DOWN THE SPECIFICATIONS OF THE FUSES.

The air conditioner board (PCB) is equipped with a fuse for overcurrent protection. Fuse specifications are printed on the circuit board, for example:

Indoor unit: T5A/250VAC

NOTE: The fuse is ceramic.

- 1** Prepare the cable for connection:
 - Using a wire stripper, strip the rubber sheath at both ends of the cable and expose approximately 40 mm of the internal conductors.
 - Strip the insulation sheath at the ends of the conductors.
 - Using a crimping tool, crimp U-type wire terminals to the ends of the conductors.



CAUTION

When crimping, clearly identify live cables ("L") and other cables.

- 2** Open the front panel of the indoor unit.
- 3** Using a screwdriver, open the terminal compartment cover on the right side of the unit. This will give you access to the terminal block.

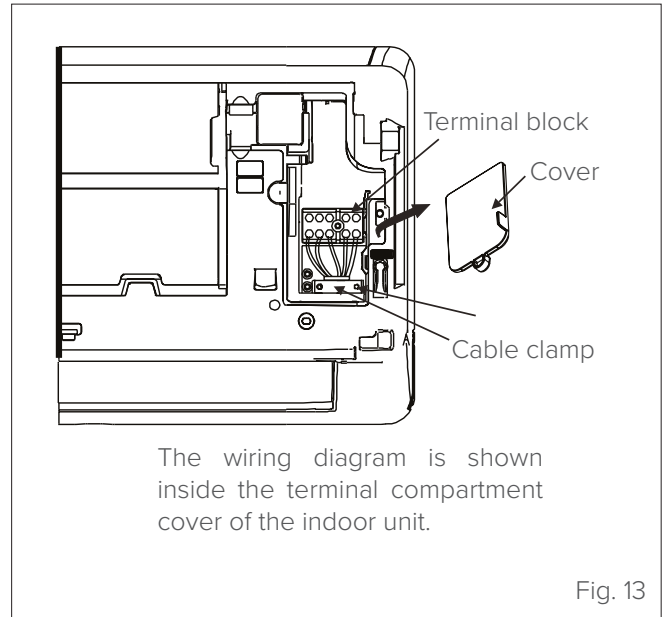

Fig. 13



WARNING

All connections must be made exactly as shown in the wiring diagram on the inside of the terminal block cover of the indoor unit.

- 4** Unscrew the cable clamp under the terminal block and hold it aside.
- 5** Looking at the back of the unit, remove the plastic panel located on the left side of the base.
- 6** Route the electrical cables through this opening, proceeding from the back of the unit to the front.
- 7** Looking at the front side of the unit, match the colours of the cables to the labels on the terminal block, connect the U-shaped terminals and screw each cable securely to the corresponding terminal.



CAUTION DANGER

DO NOT SWITCH LIVE AND NEUTRAL CABLES. Such a configuration is dangerous and may cause the air conditioner to malfunction.

- 8** Check that all connections are stable, then close the cable clamp to secure the signal cable to the unit. Screw the cable clamp on firmly.
- 9** Replace the cover on the front side of the unit and replace the plastic panel on the back.

Connections in SINGLE Split configuration

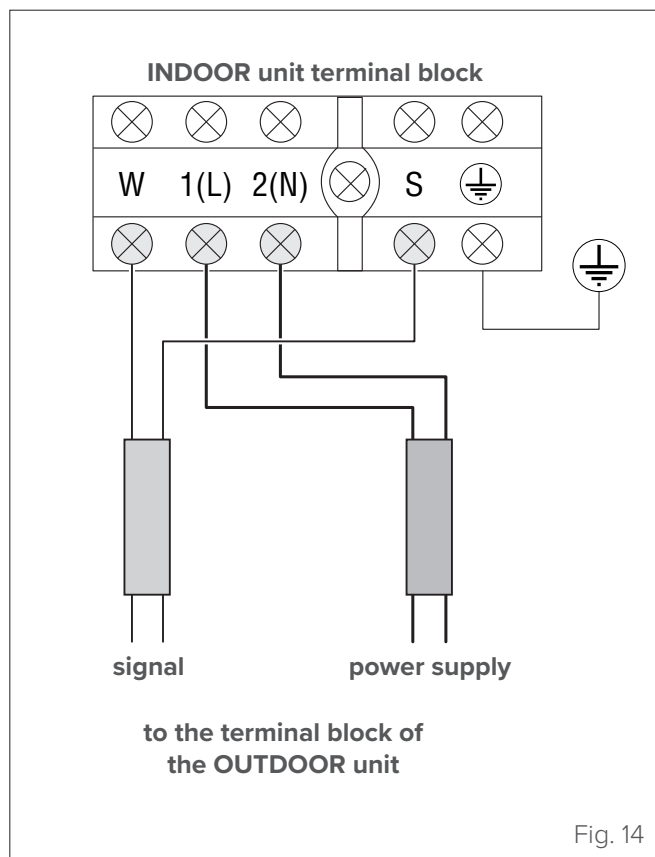

2.4.7 Wrap the pipes and cables

It is necessary to wrap the coolant pipes, drainage pipe and electrical cables together; this reduces the space occupied, protects them and insulates them before passing them through the hole in the wall.

- 1 Assemble the drainage pipe, coolant pipes and cables as indicated in "Fig. 16".

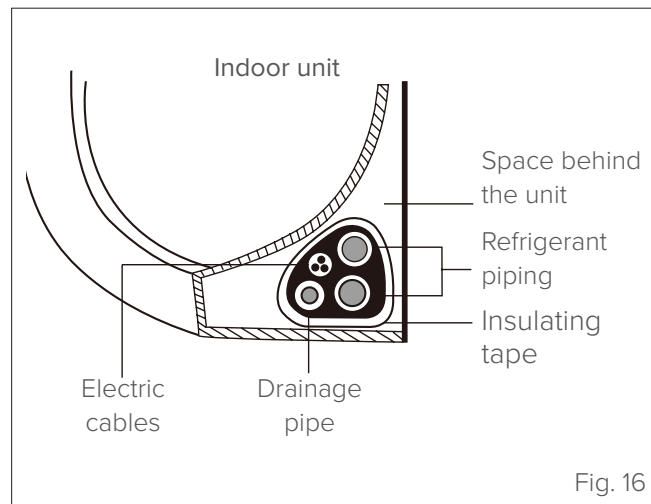

Connections in MULTI Split configuration

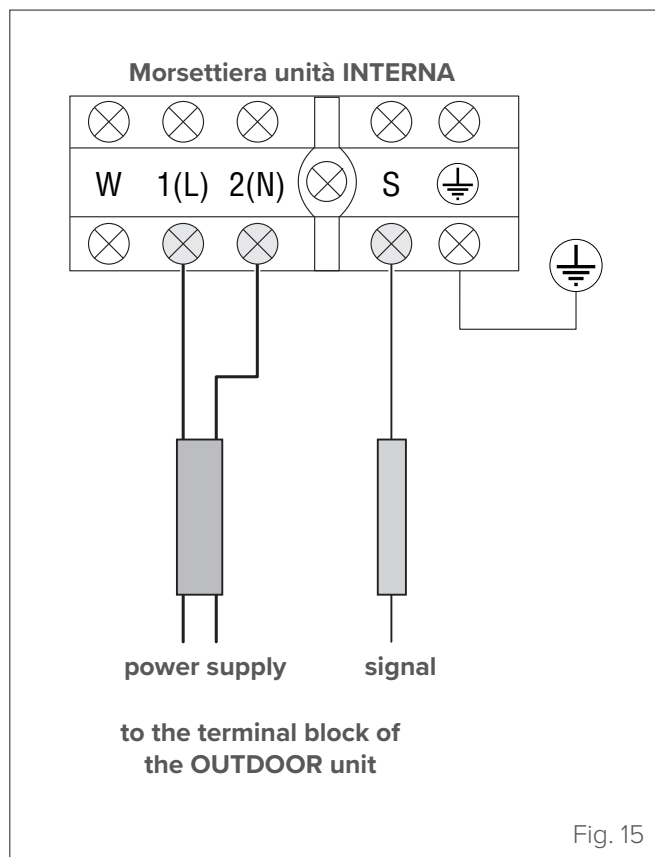

CAUTION

- Make sure that the drainage pipe is on the lower part of the unit. Placement of the drainage pipe at the top of the unit may cause the drain pan to overflow, which may result in fire or water damage.
- When winding the pipes and cables, leave the ends of the pipes free. These should be accessible to check for leaks after installation is complete (see section "3.2 Electrical dispersion and gas leakage control" of the outdoor unit manual).
- When assembling cables, avoid twisting or tangling the signal cable with other types of cable.

- 2 Using vinyl adhesive tape, fasten the drain pipe to the bottom side of the coolant pipes.
- 3 Using insulating tape, wrap the electrical cables, coolant pipes and drainage pipe together. Check that all components are joined together as indicated in "Fig. 16"

2.4.8 Mounting the indoor unit

CASE "A": If you have installed a new connection pipe to the outdoor unit, proceed as follows:

- 1 Check that the ends of the coolant pipes are closed tightly to prevent dust or foreign materials from entering.
- 2 Slowly pass the unit containing the coolant pipes, drainage pipe and electrical cables through the hole in the wall.
- 3 Hook the top of the indoor unit to the top hook of the mounting plate.
- 4 Check that the unit is securely attached to the plate by applying light pressure to the left and right of the unit. The unit must not move or swing.
- 5 Applying uniform pressure, push on the lower half of the unit. Continue pushing until the unit clicks onto the hooks located along the base of the mounting plate.
- 6 Once again check that the unit is securely mounted on the plate by applying light pressure to the left and right of the unit.

CASE "B": If the refrigerant piping is already embedded in the wall, proceed as follows:

- 1 Hook the top of the indoor unit to the top hook of the mounting plate.
- 2 Use a bracket or wedge to lift the unit so that there is enough space to connect the refrigerant piping, electrical cables and drainage pipe (see "Fig. 17").

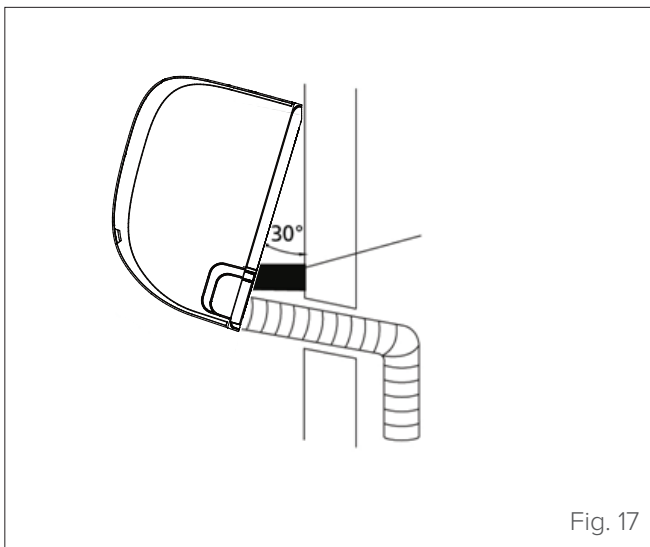

- 3 Connect the drainage pipe and refrigerant piping (for instructions, see section "6 Notions on refrigerant piping connection" of the outdoor unit manual).
- 4 Leave the pipe connection point exposed so that you can check for leaks (see section "3.2 Electrical dispersion and gas leakage control" of the outdoor unit manual).
- 5 After checking for leaks, wrap the connection point with insulating tape.
- 6 Remove the bracket or wedge that holds the unit up.
- 7 Applying uniform pressure, push on the lower half of the unit. Continue pushing until the unit clicks onto the hooks located along the base of the mounting plate.



WARNING

THE UNIT IS ADJUSTABLE.

The mounting plate hooks are smaller than the holes on the back of the unit. If the space available for connecting the recessed pipes to the indoor unit is not very large, the unit can be moved left or right about 30-50 mm, depending on the model (see "Fig. 18").

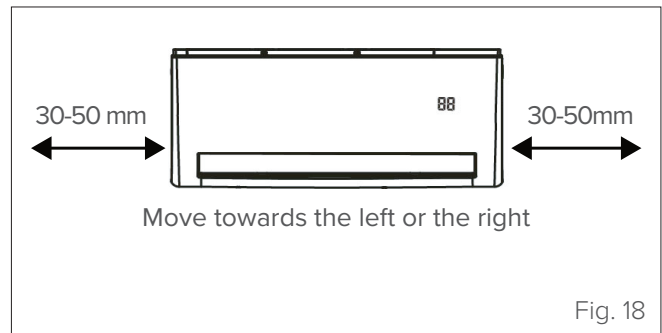

3 USE

3.1 Description of system components

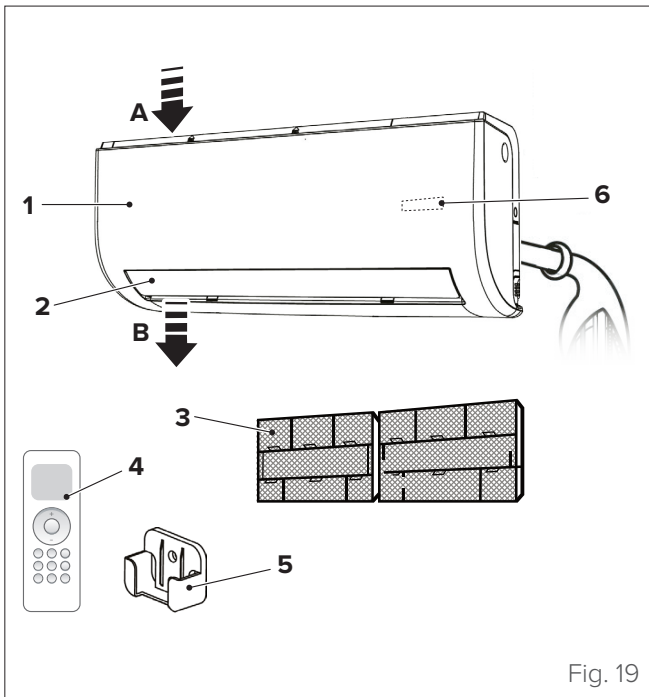

Fig. 19

- A** Air return
B Air supply
- 1** Indoor unit
2 Ventilation slit
3 Air filter
4 Remote control
5 Remote control support
6 Display LED



WARNING

The images in this manual are provided for illustrative purposes only. The appearance of your device may differ slightly from the illustrations shown here. Refer to the actual characteristics of the unit.

3.2 Meaning of the display codes

Icon	Description
	It displays for 3 seconds when: <ul style="list-style-type: none"> • you set the start-up timer (TIMER ON) • Ioniser filter, SWING, TURBO, ECO or SILENCE functions are activated
	It displays for 3 seconds when: <ul style="list-style-type: none"> • you set the start-up timer (TIMER OFF) • Ioniser filter, SWING, TURBO, ECO or SILENCE functions are deactivated
	When the defrost function is active
	When the Clean function is active
	When the self-cleaning function of the unit is in progress
	When the frost protection is activated
	When activating the WiFi Control function
	When activating the ECO function

NOTE: In ventilation mode (FAN), the unit shows room temperature. In other modes, the unit shows the set temperature.

3.3 Remote control

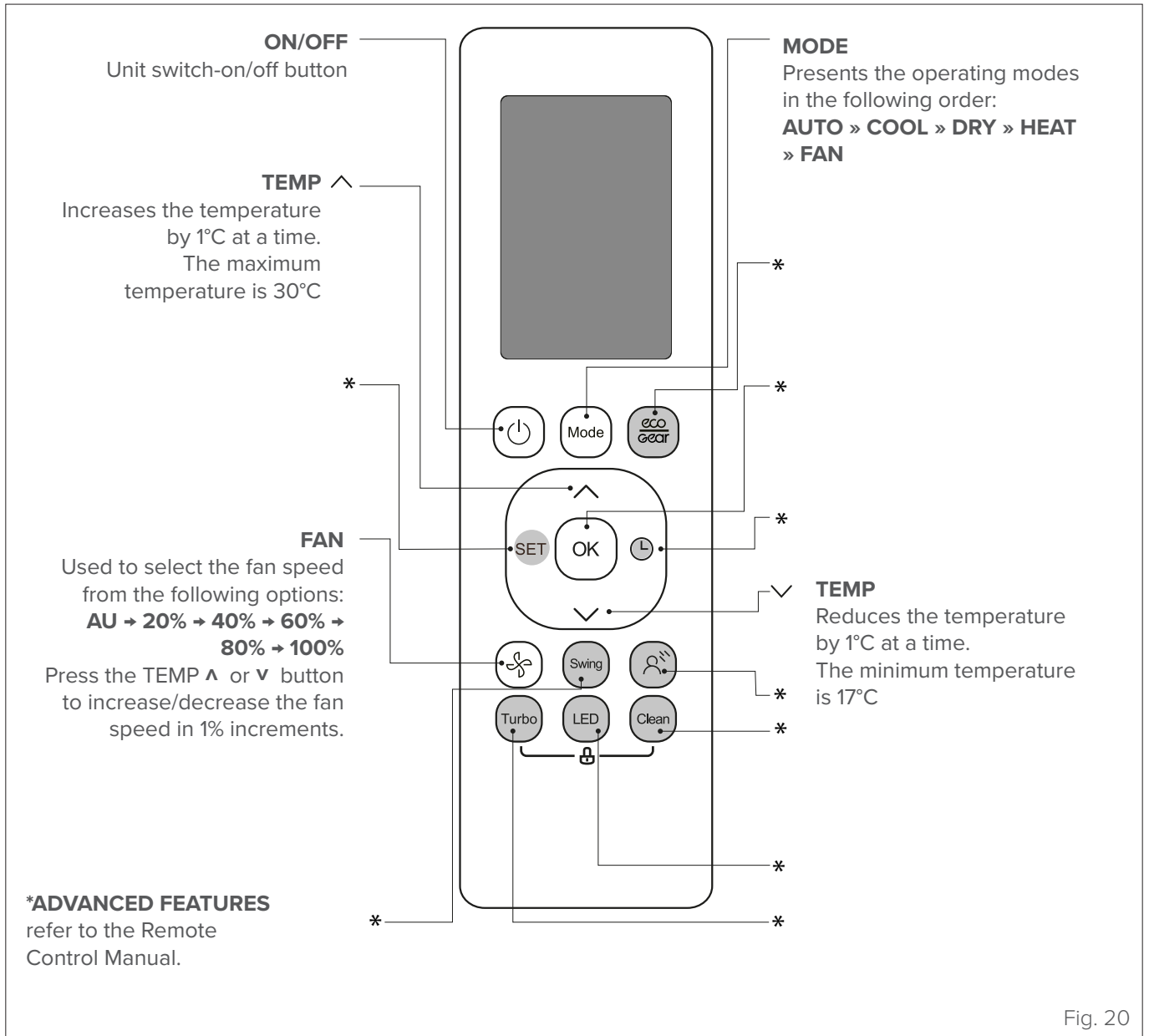

Fig. 20

3.4 Operation

For optimum performance in cooling, heating and dehumidification modes, use the unit within the temperature ranges below. If the air conditioner is used outside of these ranges, some protective functions may trip and cause suboptimal operation.

	Cooling mode	Heating Mode	Dehumidification Mode
Ambient temperature	16°C ÷ 32°C	0°C ÷ 30°C	10°C ÷ 32°C
Outdoor temperature	-15°C ÷ 50°C	-15°C ÷ 30°	0°C ÷ 50°C

To further optimise unit performance, take the following steps:

- Keep doors and windows closed.
- Limit power consumption using the start-up (TIMER ON) and shut-off (TIMER OFF) timers.
- Avoid obstructing air inlets or outlets.
- Inspect and clean the filters regularly.

3.4.1 Other functions

– Automatic restart

If the power supply to the unit is interrupted, the unit will automatically restart with the last settings when it is restored.

– Wi-Fi Control (option)

WiFi control allows you to control the air conditioner through your mobile phone and a wireless connection.

– Memory of the angle of the ventilation fins

When the unit is turned on, the ventilation fins automatically return to the last set angle.

– Detection of refrigerant leaks

The indoor unit automatically displays "EC" when it detects a refrigerant leak.



WARNING

For a detailed explanation of the unit's advanced features (such as TURBO mode and self-cleaning functions), refer to the **Remote Control Manual**.

SLEEP FUNCTION

The SLEEP function is used to reduce energy consumption while sleeping (when a constant temperature setting is not required for a comfortable climate). This function can only be activated with the remote control.

Press the **SLEEP** button when you are ready to go to bed. In Cooling mode, the unit will increase the set temperature by 1°C after 1 hour and again by 1°C after another hour. In Heating mode, the unit will lower the set temperature by 1°C after 1 hour and again by 1°C after another hour.

The SLEEP function will stop after 8 hours and will continue to operate with the last setting.

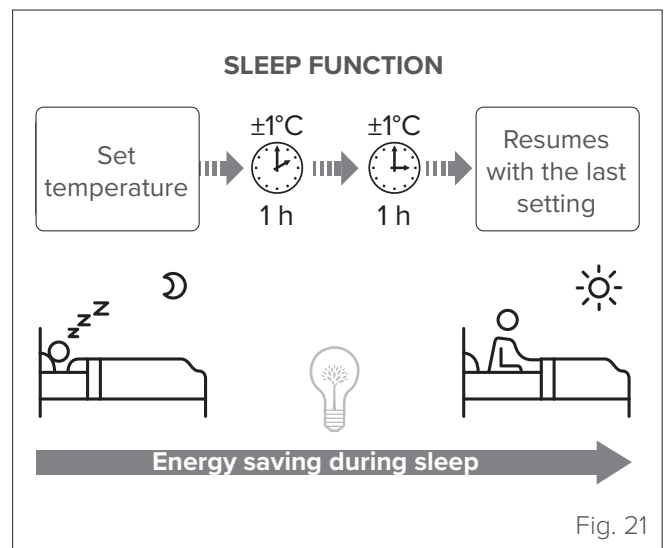

Cooling mode (+1°C) per hour for the first 2 hours
Heating mode (-1°C) per hour for the first 2 hours

Note: The SLEEP function is not available in Ventilation or Dehumidification mode.

3.4.2 Airflow angle adjustment

VERTICAL FINS ORIENTATION

With the unit turned on, use SWING button to adjust airflow direction.

- 1 To swing the ventilation slit continuously, press and hold the SWING button for 3 seconds. Press it again to stop the automatic function.

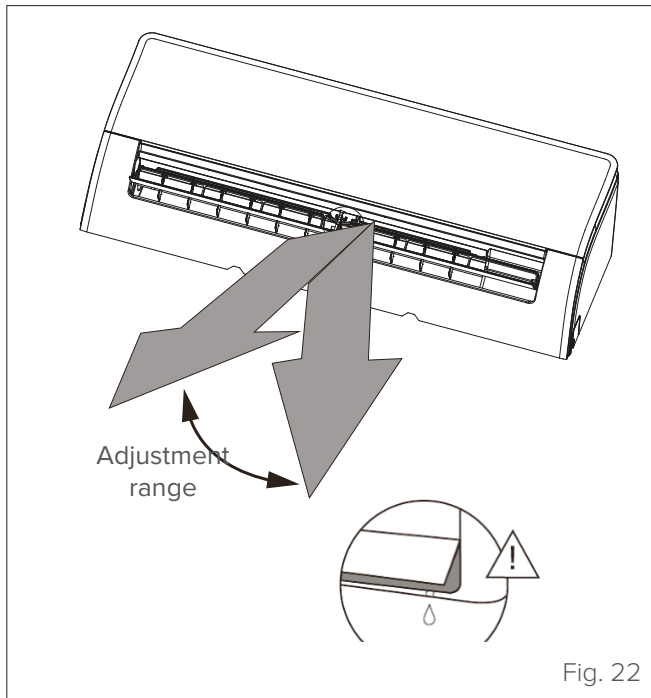

WARNING

In Cooling or Dehumidifying mode, do not leave the ventilation fins at an angle that is too vertical for a prolonged period. In this position condensation may form on the slit flap, which may then fall on the floor and furniture (see "Fig. 22").

In Cooling or Heating mode, adjustment of the ventilation fins to an angle that is too vertical may reduce the performance of the unit due to restricted airflow.



IT IS PROHIBITED

adjust the ventilation fins with your hands, because doing so could alter the synchronism. In this case, turn off the unit and disconnect it from the power mains for a few seconds, then restart the air conditioner. The ventilations fins will reset.

HORIZONTAL FINS ORIENTATION

With the unit turned on, use the SWING button to adjust the direction of airflow.

- 1 To continuously swing the horizontal fins up and down, press the SWING button. Press it again to stop the automatic function.

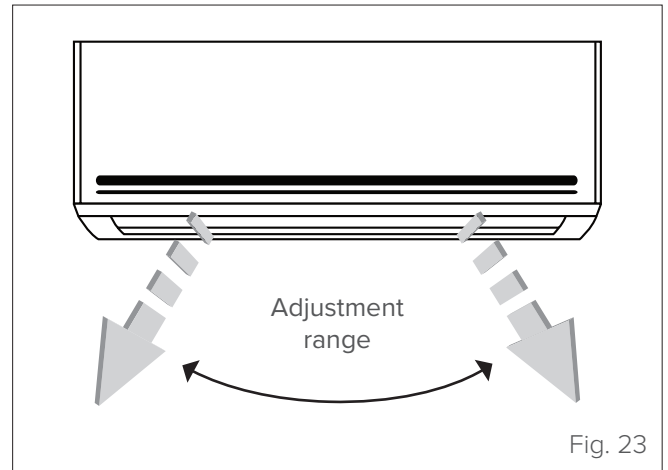

CAUTION DANGER

Do not approach or insert your fingers into the air intake and outlet section. High-speed rotation of the fan inside the unit may cause injury.

3.5 Manual operation (without remote control)

If the remote control does not work, the unit can be operated manually with the **manual control** button located on the indoor unit. Note that manual operation is only a temporary solution, and it is highly recommended to run the unit with the remote control.



WARNING

Before activating the unit manually, you must turn it off.

To operate the unit manually:

- 1 Open the front panel of the indoor unit.
- 2 Locate the manual control button on the right side of the unit.
- 3 Press the manual control button once to activate forced-automatic mode.
- 4 Press the manual control button again to activate forced cooling mode.
- 5 Press the manual control button a third time to turn the unit off.
- 6 Close the front panel.

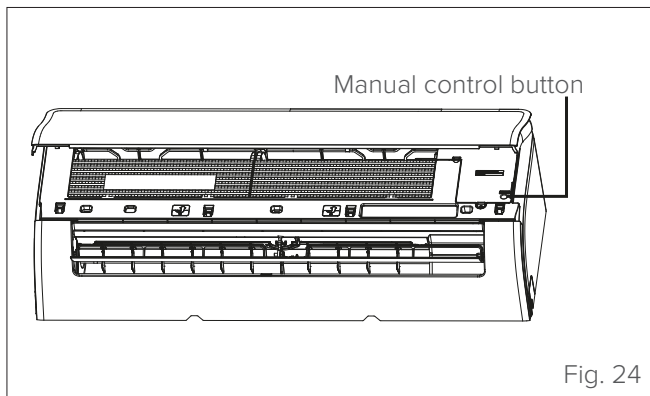

CAUTION DANGER

The manual override button is only intended for testing and emergency manoeuvres operations. It is recommended to only use it when absolutely necessary and when the remote control has been lost. To restore normal operation, activate the unit using the remote control.

4 MAINTENANCE

It is good practice to periodically clean both the internal and external parts of the appliance. This guarantees its proper functioning and durability.

Carry out periodic maintenance of the appliance in accordance with the regulations in force.

Maintenance must be carried out by qualified technical personnel.

4.1 Cleaning the indoor unit



ATTENTION ELECTRIC DANGER

Before cleaning or maintenance, always turn off the air conditioner and disconnect it from the power supply.



CAUTION

Use only a soft, dry cloth to clean the unit. If the unit is particularly dirty, you can use a cloth moistened in warm water.



IT IS PROHIBITED

- use chemicals or chemically treated cloths to clean the unit;
- use benzene, thinners, polishing powders or other solvents to clean the unit. These substances can cause cracking or deformation of the plastic surface;
- use water at temperatures above 40°C to clean the front panel. Very hot water can cause the panel to deform or discolour.

4.2 Cleaning the air filter

Obstruction of the air filter can reduce the efficiency of the unit and can be harmful to health. It is recommended to clean the filter every two weeks.



ATTENTION ELECTRIC DANGER

- Before replacing or cleaning the filter, turn the unit off and disconnect it from the power supply.
- Do not wash the inside of the unit with water. Water could damage the insulation and create a risk of electrocution.



CAUTION DANGER

When removing the filter, avoid touching the metal parts of the unit. Sharp metal edges can be sharp.



IT IS PROHIBITED

dry the filter by exposing it to direct sunlight. The filter may shrink

- 1 The air filter is under the panel.
- 2 Press the buttons on both sides.

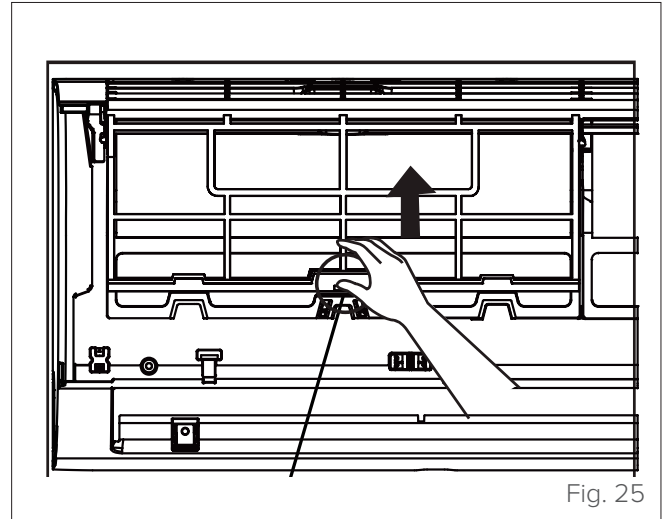

Fig. 25

- 3 Now pull the filter out.

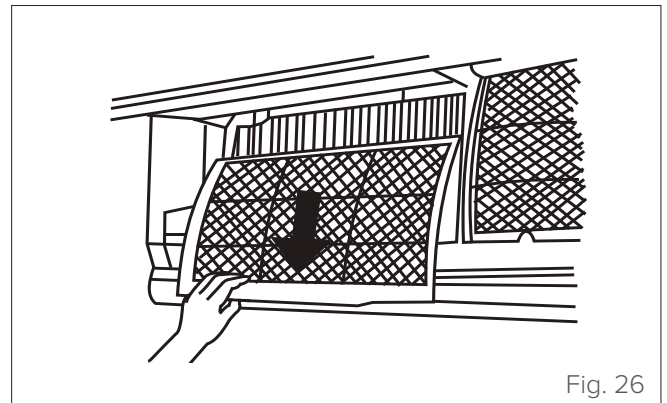

Fig. 26

- 4 Wash the filter with warm soapy water. Use a mild detergent.
- 5 Rinse the filter with clean water and shake it to remove excess water.

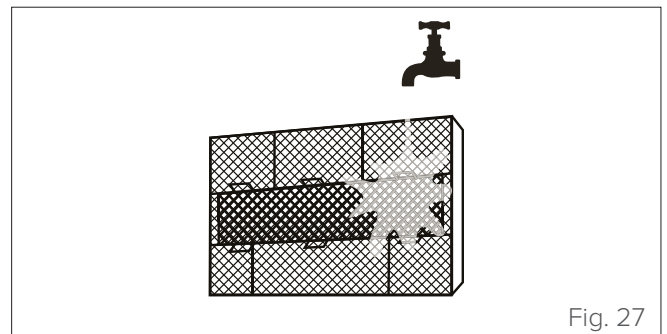

Fig. 27

- 6 Let it dry in a cool, dry place, avoiding direct sunlight.
- 7 Once dry, reinsert the filter into the indoor unit.

4.3 Cleaning the outdoor unit

If the battery in the outdoor unit is clogged, remove the leaves and debris and then remove the dust with a jet of air or water.

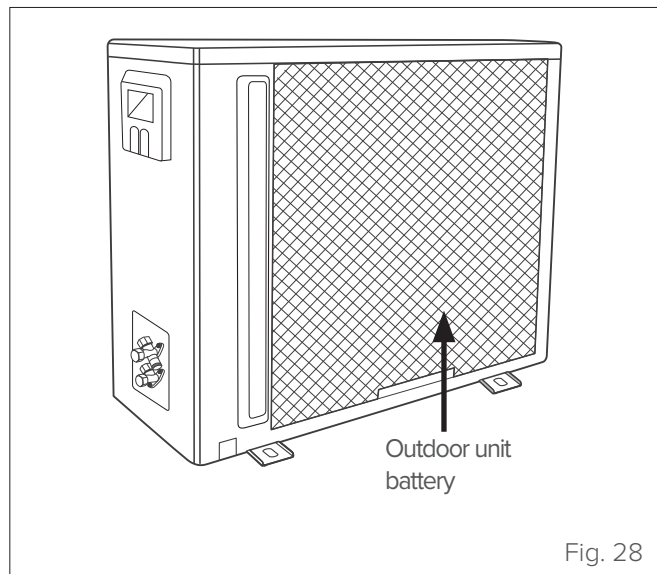
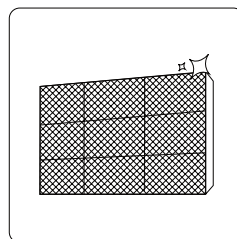

Fig. 28

4.4 Extended periods of inactivity

If you do not plan to use the air conditioner for an extended period of time, proceed as follows:



Clean all filters

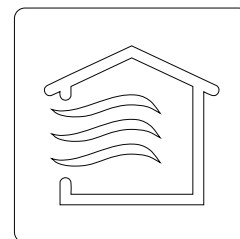

Activate the Ventilation mode until the unit is completely dry

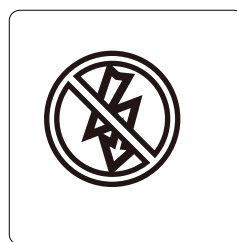

Turn off the unit and disconnect it from the mains power supply

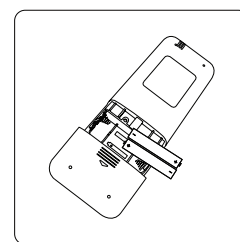

Remove the batteries from the remote control

4.5 Maintenance at the start of the season

After a long period of non-use, or before a period of frequent use, proceed as follows:

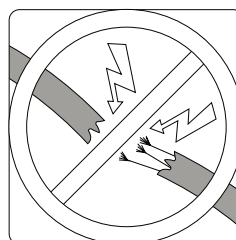

Check that the cables are intact

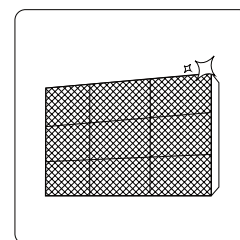

Clean all filters



Check that there are no leaks

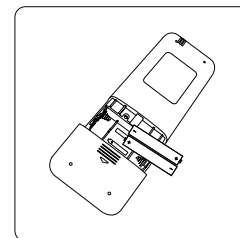

Replace batteries

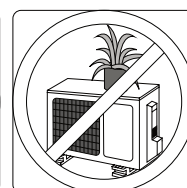
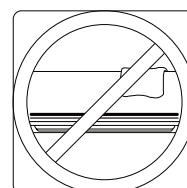

Check that the air inlets and outlets are not obstructed

4.6 Troubleshooting



CAUTION DANGER

If any of the following conditions occur, turn the unit off immediately.

- The power cord is damaged or unusually hot.
- You can smell burning.
- The unit makes loud or abnormal noises.
- A fuse blows or the circuit breaker trips frequently.
- Water or other substance have fallen into the unit, or water or other substance have leaked from the unit.

DON'T TRY TO SOLVE THE PROBLEM YOURSELF. IMMEDIATELY CONTACT AN AUTHORISED SERVICE CENTRE.

4.6.1 Common problems

The problems described below do not represent malfunctions and, in most cases, do not require repair.

Problem	Possible causes
The unit does not turn on when the ON/OFF button is pressed	- The unit has a 3-minute delay protection feature that prevents overloading. The unit cannot be restarted until three minutes have elapsed since shutdown.
The unit switches from Cooling/Heating mode to Ventilation mode	- The unit can change operating mode to prevent frost formation. As the temperature rises, the unit will return to the previously set mode. - The set temperature has been reached and the compressor has switched off. The unit will continue to operate in response to temperature changes.
The indoor unit emits a white haze	- In humid regions, a marked difference in temperature between the air in the room and the air conditioning can cause a white mist to form.
Both the indoor and outdoor units emit a white haze	- When the unit restarts in Heating mode after a defrost cycle, it may emit a white haze due to moisture generated by the defrost process.
The indoor unit is noisy	- An air current noise is heard when the ventilation slit returns to its original position. - You will hear a crackling sound after the Heating mode is activated due to the expansion and contraction of the plastic parts of the unit.
Both the indoor and outdoor units are noisy	- Slight hissing during operation: this noise is normal and is due to the circulation of refrigerant gas in the indoor and outdoor units. - Slight hissing when the system starts up, immediately after shutdown or during defrosting: this noise is normal and is caused by stopping or changing the direction of the refrigerant gas. - Cracking: due to normal expansion and contraction of plastic and metal parts caused by temperature changes during operation.
The outdoor unit is noisy	- The unit emits various noises depending on the operating mode in use.
Indoor or outdoor unit emits dust	- During a long period of non-use, dust may accumulate on the unit and be emitted when it is turned on again. This problem can be partly solved by covering the unit during prolonged periods of inactivity.
The unit smells bad	- The unit may absorb ambient odours (furniture, cooking, cigarettes, etc.) and emit them during operation. - Mold has formed on the unit's filters and must be removed.
The fan of the outdoor unit is not working	- During operation, fan speed is controlled to optimise the operation of the air conditioner.
Operation is erratic or unpredictable, or the unit does not respond to commands	Interference from mobile phone repeaters and remote amplifiers may cause the unit to malfunction. In this case, try to solve the problem as follows: - Disconnect the unit from the power mains and then reconnect it. - Press the ON/OFF button on the remote control to restart operation.

NOTE: if the problem persists, contact your local dealer or nearest service centre, providing a detailed description of the malfunction and specifying the model number.

4.6.2 Abnormalities and remedies

If problems occur, please check the following before contacting a service centre.

Anomalies	Possible causes	Remedies
Unsatisfactory cooling performance	The set temperature may be higher than the room temperature	Set a lower temperature
	The heat exchanger of the indoor or outdoor unit is dirty	Clean the heat exchanger (Service Centre)
	The air filter is dirty	Remove the filter and clean it following instructions
	The air inlet or outlet of the indoor or outdoor unit is blocked	Turn off the unit, remove the cause of the obstruction and turn the air conditioner on again
	Open doors and windows	Close doors and windows when using the unit
	Sunlight produces excessive heat	Close curtains and windows during the hottest hours or when the sun is brightest
	Too many heat sources in the room (people, computers, electronic devices, etc.)	Reduce heat sources
	Low refrigerant level due to leakage or prolonged use	Check for leaks, reseal the system if necessary and refill the coolant (Service Centre)
	The SILENCE function is active	The SILENCE function can reduce product performance by reducing the frequency of operation. Deactivate the SILENCE function.
The unit does not work	Power failure	Wait for power to be restored
	The unit is turned off	Switch on the device
	The fuse is blown	Replace the fuse (Service Centre)
	Remote control batteries are low	Replace batteries
	Protection function with 3-minute delay is active	Wait three minutes before restarting the unit
	The timer is active	Deactivate the timer
The unit starts or stops frequently	The amount of refrigerant in the system is excessive or insufficient	Check for leaks and top up the coolant (Service Centre)
	Incompressible gas has entered or moisture has penetrated the system.	Evacuate the system and recharge the refrigerant (Service Centre)
	The compressor is faulty	Replace the compressor (Service Centre)
	The voltage is too high or too low	Install a voltage controller (Service Centre)
Unsatisfactory heating performance	The outside temperature is extremely low	Using an auxiliary heating appliance
	Cold air enters through doors and windows	Close doors and windows when using the unit
	Low refrigerant level due to leakage or prolonged use	Check for leaks, reseal the system if necessary and refill the coolant (Service Centre)
The indicator lights continue to flash	The unit may stop or continue to operate properly. If the indicator lights continue to flash or error codes are displayed, wait approximately 10 minutes. The problem may solve itself. If not, disconnect the unit from the power mains and reconnect it. Turn on the unit. If the problem persists, disconnect the unit from the power supply and contact the nearest service centre.	
An error code appears on the display of the indoor unit: • E0, E1, E2... • P1, P2, P3... • F1, F2, F3...		

NOTE: if, after performing the above checks and diagnostic procedures, the problem persists, turn the unit off immediately and contact an authorised service centre.

4.7 Error codes displayed on the indoor unit display

Error code	Cause	Timer light
dF	Defrost	--
CL	Filter cleaning reminder (power on display for 15 seconds)	--
CL	Active clean	--
nF	Filter replacement reminder(power on display for 15 seconds)	--
FP	Heating in room temperature under 8°C	--
FC	Forced cooling	--
AP	AP mode of WIFI connection	--
CP	Remote switched off	--
EH 00 / EH 0A	Indoor unit EEPROM parameter error	OFF
EL 01	Indoor/outdoor unit communication error	OFF
EH 02	Zero-crossing signal detection error	OFF
EH 03	The indoor fan speed is operating outside of the normal range	OFF
EC 51	Outdoor unit EEPROM parameter error	OFF
EC 52	Condenser coil temperature sensor T3 is in open circuit or has short circuited	OFF
EC 53	Outdoor room temperature sensor T4 is in open circuit or has short circuited	OFF
EC 54	Compressor discharge temperature sensor TP is in open circuit or has short circuited	OFF
EC 56	Evaporator coil outlet temperature sensor T2B is in open circuit or has short circuited (for free-match indoor units)	OFF
EH 60	Indoor room temperature sensor T1 is in open circuit or has short circuited	OFF
EH 61	Evaporator coil middle temperature sensor T2 is in open circuit or has short circuited	OFF
EC 07	The outdoor fan speed is operating outside of the normal range	OFF
EH 0b	Indoor PCB/Display board communication error	OFF
EL 0C	Refrigerant leakage detection	OFF
PC 00	IPM malfunction or IGBT over-strong current protection	Flashing
PC 01	Over voltage or over low voltage protection	Flashing
PC 02	Top temperature protection of compressor or High temperature protection of IPM module or High pressure protection	Flashing
PC 04	Inverter compressor drive error	Flashing
PC 08	Current overload protection	Flashing
PC 40	"Communication error between outdoor main chip and compressor driven chip"	Flashing
PC 03	Low pressure protection	Flashing
--	Indoor units mode conflict (match with multi outdoor unit)	ON

NOTE: To case of an alarm, the operation light (flashes)

ERROR CODES DISPLAYED ON THE REMOTE CONTROL.

Use the “Query mode” function on the remote control to display the alarms (see: technical manual special modes).

Error code	Description
EH 00 / EH 0A	Indoor unit EEPROM parameter error
EL 01	Indoor / outdoor unit communication error
EH 02	Zero-crossing signal detection error
EH 30	Over low voltage protection of indoor external fan
EH 31	Over voltage protection of indoor external fan
EH 03	The indoor fan speed is operating outside of the normal range
EC 51	Outdoor unit EEPROM parameter error
EC 52	Condenser coil temperature sensor T3 is in open circuit or has short circuited
EC 53	Outdoor room temperature sensor T4 is in open circuit or has short circuited
EC 54	Compressor discharge temperature sensor TP is in open circuit or has short circuited
EC 56	Evaporator coil outlet temperature sensor T2B is in open circuit or has short circuited
EH 60	Indoor room temperature sensor T1 is in open circuit or has short circuited
EH 61	Evaporator coil temperature sensor T2 is in open circuit or has short circuited
EC 07	The outdoor fan speed is operating outside of the normal range
EH 0b	Indoor PCB/Display board communication error
EL 0C	Refrigerant leak detected
PC 00	IPM malfunction or IGBT over-strong current protection
PC 10	Over low voltage protection
PC 11	Over voltage protection
PC 12	DC voltage protection
PC 02	Compressor top high temperature protection (OLP)
PC 03	Pressure protection
PC 40	Communication error between outdoor main chip and compressor driven chip
PC 41	Current Input detection protection
PC 42	Compressor start error
PC 43	Lack of phase (3 phase) protection
PC 44	No speed protection
PC 45	341PWM error
PC 46	Compressor speed malfunction
PC 49	Compressor over current protection
--	Indoor units mode conflict(match with multi outdoor unit)
PC 0A	Condenser high temperature protection
PC 06	Compressor discharge temperature protection
PC 08	Outdoor current protection
PH 09	Anti-cold air in heating mode

PC 0F	PFC module malfunction
PC 0I	Outdoor ambient temperature too low
PH 90	Evaporator coil temperature over high protection
PH 91	Evaporator coil temperature over low Protection
LC 05	Frequency limit caused by voltage
LC 03	Frequency limit caused by current
LC 02	Frequency limit caused by TP
LC 01	Frequency limit caused by T3
LH 00	Frequency limit caused by T2
LC 06	Frequency limit caused by PFC
LH 07	Frequency limit caused by remote controller
NA	no malfunction or protection

5 DISPOSAL

The manufacturer is registered on the National EEE Register, in compliance with implementation of Directive 2012/19/EU and pertinent national regulations on electrical and electronic equipment waste.

This Directive requires electrical and electronic equipment to be disposed of properly.

Equipment bearing the crossed-out wheelie bin symbol must be disposed of separately at the end of its lifecycle to prevent damage to human health and to the environment.

Electrical and electronic equipment must be disposed of together with all of its parts.

To dispose of “household” electrical and electronic equipment, the manufacturer recommends contacting an authorised dealer or an authorised ecological site.

“Professional” electrical and electronic equipment must be disposed of by authorised personnel through established waste disposal authorities around the country.

In this regard, here is the definition of household WEEE and professional WEEE.

WEEE from private households: WEEE originating from private households and WEEE which comes from commercial, industrial, institutional and other sources which, because of its nature and quantity, is similar to that from private households. Subject to the nature and quantity, where the waste from EEE was likely to have been used by both a private household and users of other than private households, it will be classed as private household WEEE;

Professional WEEE: all WEEE which comes from something other than private households.

This equipment may contain:

- refrigerant gas, the entire contents of which must be recovered in suitable containers by specialised personnel with the necessary qualifications;
- lubrication oil contained in compressors and in the refrigeration circuit to be collected;
- mixtures with antifreeze in the water circuit, the contents of which are to be collected;
- mechanical and electrical parts to be separated and disposed of as authorised.

When the components to be replaced for maintenance purposes are removed or when the entire unit reaches the end of its life and needs to be removed from the installation, waste should be separated by its nature and disposed of by authorised personnel at existing collection centres.



6 ATTACHMENTS

6.1 Indoor unit wiring diagrams

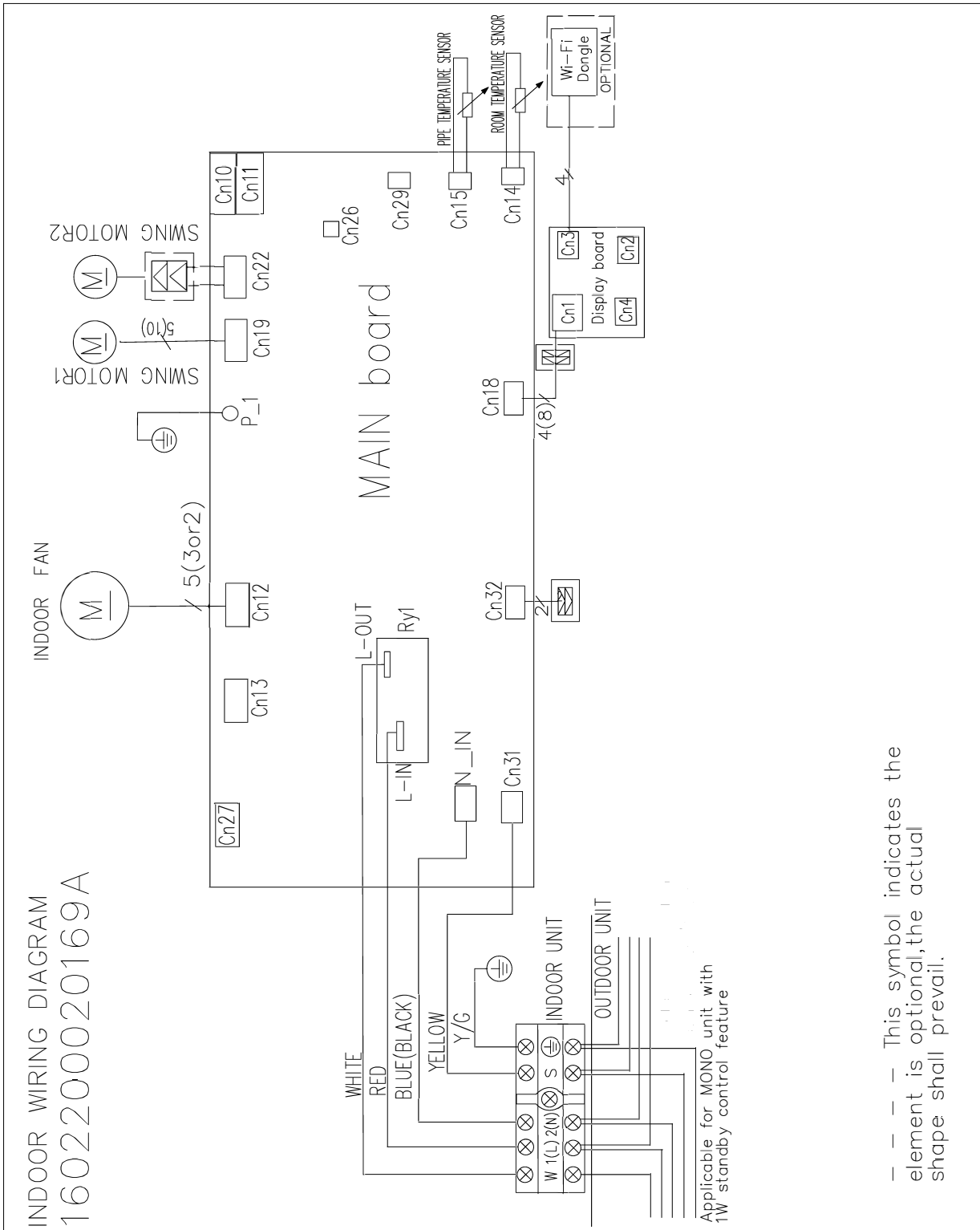

SERIES	SIZE
ILA1-Y	27M - 35M - 53M

INDOOR WIRING DIAGRAM
1602200003662A

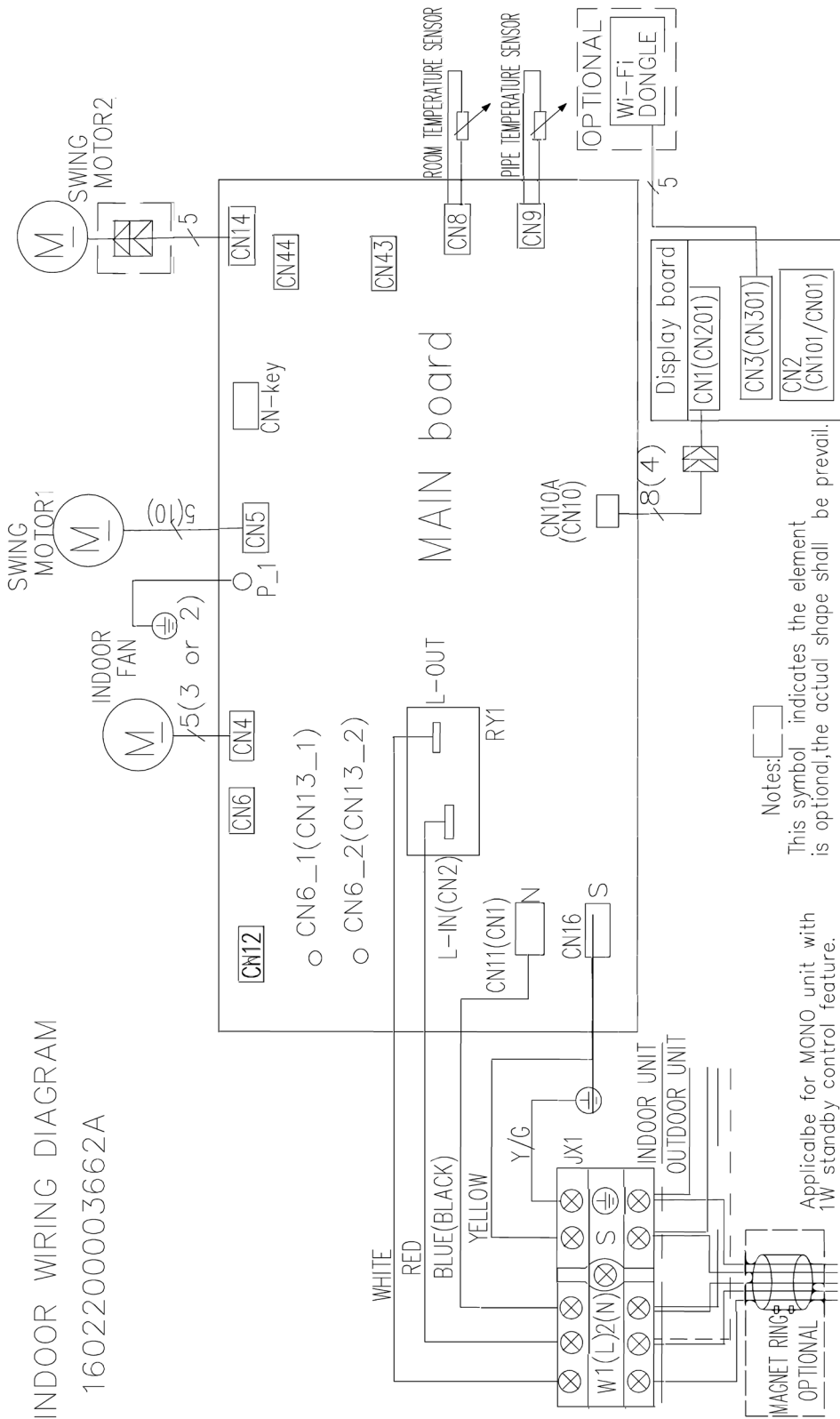

SERIES	SIZE
ILA1-Y	70M

6.2 Conformance Statement



DECLARATION OF CONFORMITY EU

DICHIARAZIONE DI CONFORMITÀ UE
KONFORMITÄTSEKTLÄRUNG EU
DECLARATION DE CONFORMITE EU
DECLARACIÓN DE CONFORMIDAD EU

WE DECLARE UNDER OUR SOLE RESPONSIBILITY THAT THE MACHINE

DICHIARIAMO SOTTO LA NOSTRA SOLA RESPONSABILITÀ CHE LA MACCHINA
WIR ERKLÄREN EIGENVERANTWORTLICH, DASS DIE MASCHINE
NOUS DÉCLARONS SOUS NOTRE SEULE RESPONSABILITÉ QUE LA MACHINE
EL FABRICANTE DECLARA BAJO SU EXCLUSIVA RESPONSABILIDAD QUE LA MÁQUINA

CATEGORY	DIRECT EXPANSION TERMINALS - Heat pump
CATEGORIA	TERMINALI AD ESPANSIONE DIRETTA - Pompa di calore
KATEGORIE	DIREKTVERDAMPFUNGSGERÄTE - Wärmepumpe
CATEGORIE	TERMINAUX À DÉTENTE DIRECTE - Pompe à chaleur
CATEGORIA	TERMINALES POR EXPANSIÓN DIRECTA - Bomba de calor

TYPE / TIPO / TYP / TYPE / TIPO

ILA1-Y 27M - ILA1-Y 35M
ILA1-Y 53M - ILA1-Y 70M

- **COMPLIES WITH THE FOLLOWING EEC DIRECTIVES, INCLUDING THE MOST RECENT AMENDMENTS, AND THE RELEVANT NATIONAL HARMONISATION LEGISLATION CURRENTLY IN FORCE:**
- RISULTA IN CONFORMITÀ CON QUANTO PREVISTO DALLE SEGUENTI DIRETTIVE CEE, COMPRESE LE ULTIME MODIFICHE, E CON LA RELATIVA LEGISLAZIONE NAZIONALE DI RECEPIMENTO:
- DEN IN DEN FOLGENDEN EWG-RICHTLINIEN VORGEGEHENEN VORSCHRIFTEN, EINSCHLIEßLICH DER LETZTEN ÄNDERUNGEN, SOWIE DEN ANGEWANDTEN LANDESGESETZEN ENTSPRICHT:
- EST CONFORME AUX DIRECTIVES CEE SUIVANTES, Y COMPRIS LES DERNIÈRES MODIFICATIONS, ET À LA LÉGISLATION NATIONALE D'ACCUEIL CORRESPONDANTE:
- ES CONFORME A LAS SIGUIENTES DIRECTIVAS CEE, INCLUIDAS LAS ÚLTIMAS MODIFICACIONES, Y A LA RELATIVA LEGISLACIÓN NACIONAL DE RECEPCIÓN:

- 2014/35/EC** **low voltage directive**
direttiva bassa tensione
Bestimmungen der Niederspannungsrichtlinie
directive basse tension
directiva de baja tensión
- 2014/30/UE** **electromagnetic compatibility**
compatibilità elettromagnetica
Elektromagnetische Verträglichkeit
compatibilité électromagnétique
compatibilidad electromagnética
- 2009/125/CE** **Ecodesign /Progettazione ecocompatibile / Ecodesign / Éco-conception / Ecodiseño**
- 2011/65/UE** **2015/863/UE** **RoHS**

-Unit manufactured and tested according to the followings Standards:	EN 60335-2-40 :2003+A11+A12+A1+A2+A13
-Unità costruita e collaudata in conformità alle seguenti Normative:	EN 60335-1 :2013+A11+A13+A1+A14+A2+A15 EN 62233 :2008
-Unité construite et testée en conformité avec les Réglementations suivantes	EN IEC 55014-1 :2021 EN IEC 55014-2 :2021
-Unidad construida y probada de acuerdo con las siguientes Normativas	EN IEC 61000-3-2 :2019+A1 :2021 EN 61000-3-3 :2013+A1 :2019
-Gebautes und geprüftes Gerät nach folgenden Normen	EN 62321-1 :2013 EN 62321-2 :2014 EN 62321-3-1 :2014
	EN 62321-4 :2014 EN 62321-5 :2014 EN 62321-6 :2015
	EN 62321-7-1 :2015 EN 62321 :2009

-Responsible to constitute the technical file is the company n° 00708410253 and registered at the Chamber of Commerce of Belluno Italy
-Responsabile a costituire il fascicolo tecnico è la società n° 00708410253 registrata presso la Camera di Commercio di Belluno Italia
-Verantwortliche für die technischen Unterlagen zusammenstellen n° 00708410253 ist das Unternehmen bei der Handelskammer von Belluno Italien registriert
-Responsable pour compiler le dossier technique est la société n° 00708410253 enregistrée à la Chambre de Commerce de Belluno en Italie
-Encargado de elaborar el expediente técnico es la empresa N° 00708410253 registrada en la Cámara de Comercio de Belluno Italia

FELTRE, 08/11/2022

NAME / NOME / VORNAME / PRÉNOM / NOMBRE
SURNAME / COGNOME / ZUNAME / NOM / APELLIDOS
COMPANY POSITION / POSIZIONE / BETRIEBSPOSITION / FONCTION / CARGO

STEFANO BELLO
LEGALE RAPPRESENTANTE

FOR 30 YEARS WE HAVE BEEN OFFERING
SOLUTIONS FOR SUSTAINABLE COMFORT
THE WELL-BEING OF PEOPLE AND
THE ENVIRONMENT

www.clivet.com

MideaGroup
humanizing technology



sales and service



CLIVET S.p.A.

Via Camp Lonc 25, Z.I. Villapaiera 32032 - Feltre (BL) - Italy
Tel. +39 0439 3131 - info@clivet.it

CLIVET GMBH

Hummelsbütteler Steindamm 84,
22851 Norderstedt, Germany
Tel. +49 40 325957-0 - info.de@clivet.com

Clivet Group UK LTD

Units F5 & F6 Railway Triangle,
Portsmouth, Hampshire PO6 1TG
Tel. +44 02392 381235 -
Enquiries@Clivetgroup.co.uk

CLIVET LLC

Office 508-511, Elektroavodskaya st. 24,
Moscow, Russian Federation, 107023
Tel. +7495 6462009 - info.ru@clivet.com

CLIVET MIDEAST FZCO

Dubai Silicon Oasis (DSO) Headquarter Building,
Office EG-05, P.O Box-342009, Dubai, UAE
Tel. +9714 3208499 - info@clivet.ae

Clivet South East Europe

Jarušćica 9b
10000, Zagreb, Croatia
Tel. +385916065691 - info.see@clivet.com

CLIVET France

10, rue du Fort de Saint Cyr - 78180 Montigny le
Bretonneux, France
info.fr@clivet.com

Clivet Airconditioning Systems Pvt Ltd

Office No.501 & 502,5th Floor, Commercial -I,
Kohinoor City, Old Premier Compound, Off LBS
Marg, Kiroi Road, Kurla West, Mumbai
Maharashtra 400070, India
Tel. +91 22 30930200 - sales.india@clivet.com